

## 5033CUEF & 5033CTEF25 Effluent Pumps

With a rugged cast iron construction, the 5033CUEF and 5033CTEF25 can handle up to 60 gallons per minute.

### Features:

- Split Capacitor Motor - 1/3 HP continuous duty, thermal protected
- Lifts water up to 25' of vertical height
- 10' power cord, 25' cords are available for an additional charge
- Large 1 1/2" discharge for high capacity pumping
- Also available without a switch
- Non-clogging stainless steel vortex impeller
- Tethered float switch
- Handles 5/8" solids



See Pumps & Accessories Price List for Limited Warranty details.

### Performance Curve

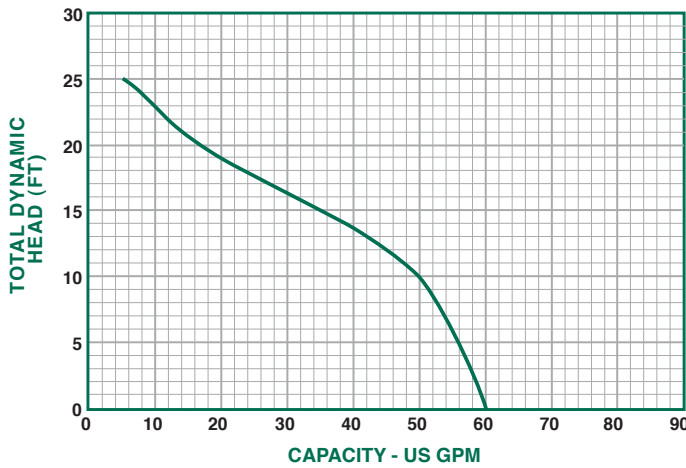

### Dimensions

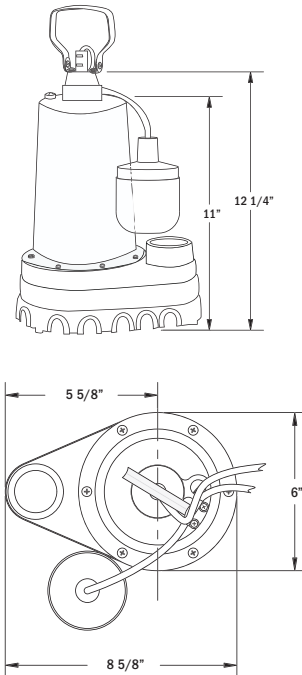

### Performance

Model	0	5	10	15	20	25
5033CUEF	0	5	10	15	20	25
5033CTEF25	60	56	50	35	15	6

### Specifications

Model No.	HP	Volts	Hz	Amps	Construction	Discharge Size	Cord Length	Solids Handling	RPM	Phase	Wt.
5033CUEF (NO SWITCH)	1/3	120	60	5.9	Cast Iron	1 1/2"	10'	5/8"	3450	1	24
5033CTEF25	1/3	120	60	5.9	Cast Iron	1 1/2"	25'	5/8"	3450	1	27

Sump, Sewage, & Effluent Pumps