

5050CUSJ & 5050CVSJ Sewage Pumps

With a rugged cast iron construction, the 5050CUSJ and 5050CVSJ can handle up to 80 gallons per minute.

Features:

- Split Capacitor Motor - 1/2 HP continuous duty, thermal protected
- Lifts water up to 25' of vertical height
- 10' Power Cord
- Large 2" discharge for high capacity pumping
- Easily handles 2" solids
- Non-clogging cast stainless steel vortex impeller
- Also available without a switch
- Vertical float switch



See Pumps & Accessories Price List for Limited Warranty details.

Performance Curve

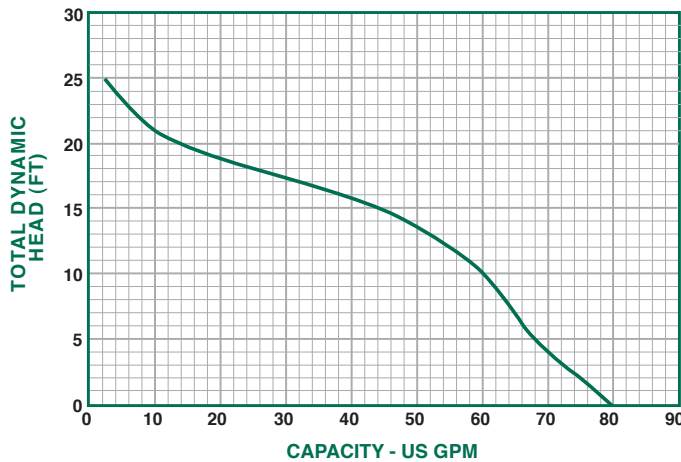

Dimensions

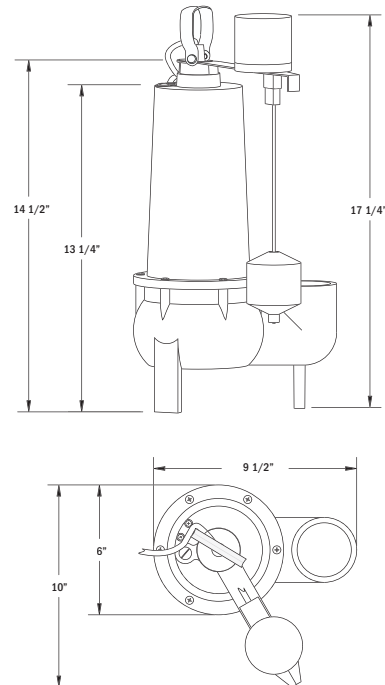

Performance

Model	Gallons per Minute in Feet					
5050CUSJ	0	5	10	15	20	25
5050CVSJ	80	68	60	44	13	2

Specifications

Model No.	HP	Volts	Hz	Amps	Construction	Discharge Size	Cord Length	Solids Handling	RPM	Phase	Wt.
5050CUSJ (NO SWITCH)	1/2	120	60	7.6	Cast Iron	2"	10'	2"	3450	1	25
5050CVSJ	1/2	120	60	7.6	Cast Iron	2"	10'	2"	3450	1	26