



PUMPS

21-P-02 REV

Product Bulletin

1 & 2 HP Grinder Pumps

A.Y. McDonald is happy to announce the addition of the 1 & 2 HP Grinder Pumps. 1 & 2 HP grinder pumps that have a 1 1/4" vertical discharge (optional 2" adapter available), and can grind up to 3" solids, and be installed on a rail system or with the supplied legs. Residential developments, commercial developments and wastewater applications

Contact your territory manager or call customer service at 800.292.2737 for additional information.

Performance

- Heads up to 103' TDH
- Flows up to 44 GPM

Motor

Internal capacitor run 115V or 208-230V, oil filled motors with upper and lower ball bearings and thermal overload protection

- Constant bearing lubrication
- Maximum motor cooling
- Runs cooler and lasts longer
- Internal overload protection
- Quiet operation
- Fasteners and shaft made from rugged, corrosion resistant stainless steel

Warranty

- 3 Years from date of manufacture



Model	HP	Volts	Phase	AMPS	Cord Length	Switch	List Price
110911GRP	1	115	1	13	20'	Manual	\$ 2,286.00
110911GRPA	1	115	1	13	20'	Wide-Angle Float	\$ 2,466.00
110912GRP	1	208-230	1	6.5	20'	Manual	\$ 2,337.00
120912GRP	2	208-230	1	15	20'	Manual	\$ 2,510.00
120212GRP*	2	208-230	1	15	20'	Manual	\$ 2,928.00

*Requires external capacitors

Product Bulletin

Seal Design

Single, mechanical, running in oil filled chamber allowing dry run and cooling

Impeller Design

Non-clog style, cast-iron vortex impeller

- Designed to generate higher heads and reduce clogging by foreign materials
- Provides non-overloading performance

Cutter Assembly

440 SST (56-60 Rockwell)

- 24,000 cuts per second and 1.5 million cuts a minute
- Designed to reduce over loading and clogging

Power Cord

Sealed entry quick disconnect power cords

- Prevents water from entering the motor housing through a cut cord
- Easy to replace in the field
- Available in lengths up to 100'

Switch

Piggy-back switch design

- Defective switches can be diagnosed over the phone
- Pump can be operated manually or supplied with other piggy-back switches
- Switch can be replaced

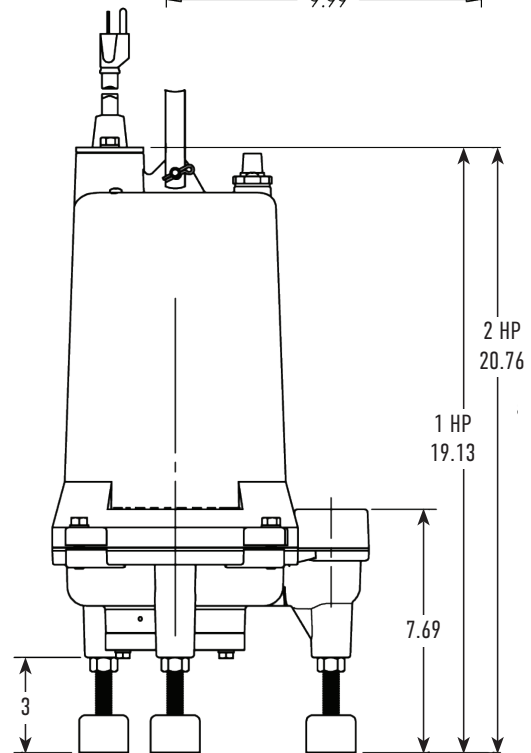
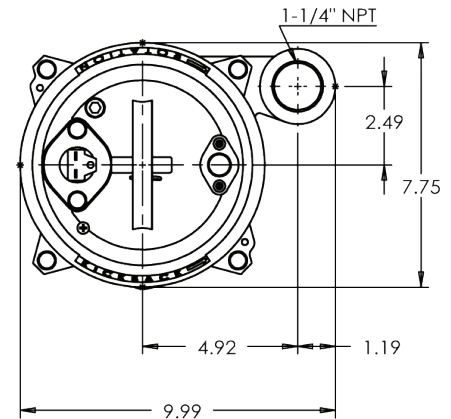

Technical Data

Discharge	1 1/4" NPT. vertical standard or optional 2"
Liquid Temperature	140°F (Intermittent)
Motor Housing	Cast Iron
Volute	Cast Iron
Seal Plate	Cast Iron
Impeller	Cast Iron / Vortex
Solids Handling	3"
Shaft	Stainless Steel
Seal Plate	Cast Iron
Shaft Seal (Single Seal)	Single Mechanical, carbon-Rotating Face, Ceramic-Stationary Face, Buna-N Elastomer, 300 Series Stainless Steel Hardware
Bearings (Upper & Lower)	Single row, ball, oil lubricated
Hardware	300 Series stainless steel
O-rings	Buna-N
Cord	20' Length standard. Up to 30' with plug and 100' without plug.
Motor (Single Phase)	1 or 2 HP 3450 RPM. 60Hz, Includes. Overload Protection in the motor, oil filled, Class F Permanent Split Capacitor
Weight	75 / 78 lbs (Manual)

Performance Curve

