

MYERS® SP25 SERIES

The Myers® SP25 series residential sump pumps are the superior choice for homeowners looking for outstanding value. The SP25A1 and SP25V1 are an excellent alternative to larger, more expensive pumps. These pumps offer great durability and will provide years of dependable service. Available with tethered or vertical float switch.



APPLICATIONS

Basement sumps, dewatering

SPECIFICATIONS

Capacities – 32 GPM (121 LPM)
Shut-off Head – 22' (6.7 m)
Operation – See page 2
Solids Handling – 1/4" (6.35 mm)
Liquids Handling – Drain water
Intermittent Liquid Temperature – Up to 140°F (60°C)
Motor/Electrical Data – 1/4 HP, 115V, 6.5A, 1Ø, 60Hz
Acceptable pH Range – 6-9
Shaft Seal – Carbon/ceramic
Housing – Cast iron
Power Cord – 10', SJTW, SJTW-A
Discharge, NPT – 1-1/2" (38 mm)
Min. Sump Diameter –
 Wide Angle: 18" (457 mm)
 Vertical: 10" (254 mm)

FEATURES

Extra Duty

Also doubles as a dewatering pump in light duty applications

Smooth Running

Impeller is designed to resist clogging

Handles the Heat

Cast iron housing improves heat dissipation and also includes built-in thermal overload protection

Efficient Operation

Features an energy-saving, permanent split capacitor run motor – dual ball bearing

Protected Motor

Long-life carbon/ceramic seal protects motor against water leakage

More Than Water

Will handle small amounts of debris in sump or dewatering operations

Choice of Floats

Available in automatic tethered or vertical switch

Easy Repair

Positive sealing, quick-disconnect power and switch cords make replacement easy

ORDERING INFORMATION

Catalog Number	HP	Volts	Phase/Cycles	Amps	Discharge Size	Switch Type	Cord Length	Approx. Wt. Lbs.
SP25A1	1/4	115	1/60	6.5	1-1/2"	Tethered Automatic	10'	15
SP25V1	1/4	115	1/60	6.5	1-1/2"	Vertical Automatic	10'	15

MYERS® SP25 SERIES

DIMENSIONS

SP25A1

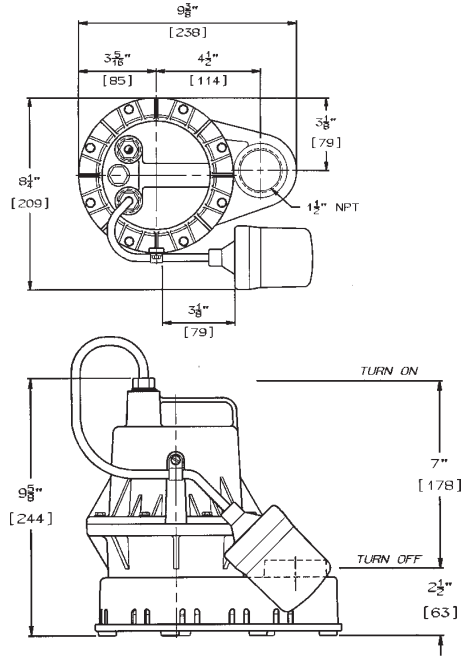

SP25V1

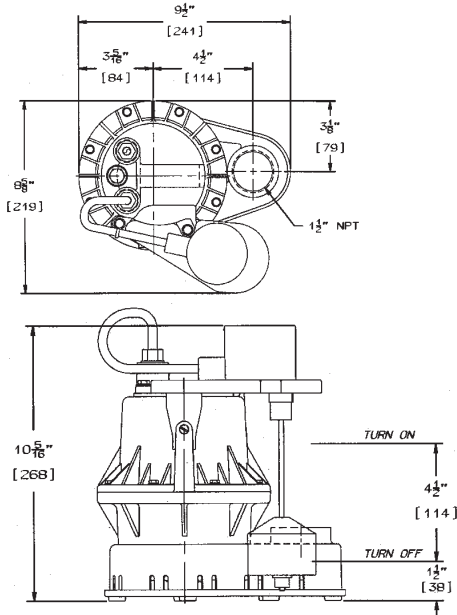

PUMP PERFORMANCE

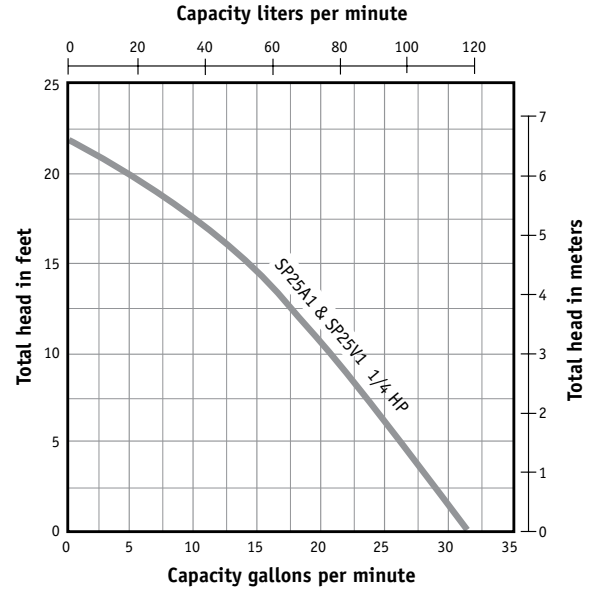

USA
293 WRIGHT STREET, DELAVAN, WI 53115 WWW.FEMEYERS.COM
PH: 888-987-8677 ORDERS FAX: 800-426-9446

CANADA
269 TRILLIUM DRIVE, KITCHENER, ONTARIO, CANADA N2G 4W5
PH: 519-606-5484 ORDERS FAX: 800-426-9446

Because we are continuously improving our products and services, Pentair reserves the right to change specifications without prior notice.