

## 5020PUUP Utility Pumps

This 5020PUUP can handle up to 26 gallons per minute. Built with a tough thermoplastic construction, it has a sleek design that allows the pump to fit in a 6" or larger opening.

### Features:

- Split Capacitor Motor -  
1/5 HP continuous duty, thermal protected
- Lifts water up to 25' of vertical height
- 10' Power Cord
- 3/4" Garden hose adapter included
- Large 1 1/4" discharge for high capacity pumping
- Clog resistant impeller



See Pumps & Accessories  
Price List for Limited Warranty details.

### Performance Curve

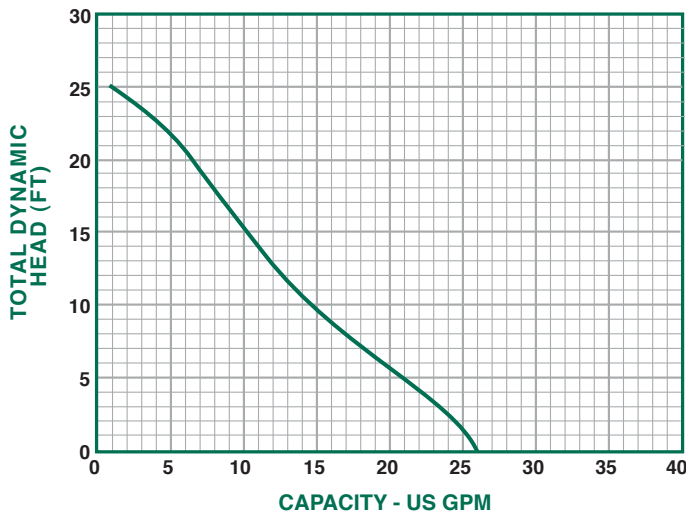

### Dimensions

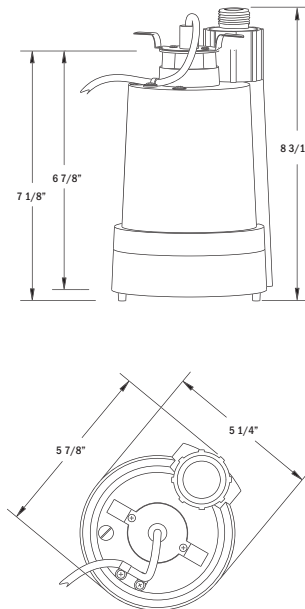

### Performance

Model	Gallons per Minute in Feet					
	0	5	10	15	20	25
5020PUUP	26	21	14	10	7	1

### Specifications

Model No.	HP	Volts	Hz	Amps	Construction	Discharge Size	Cord Length	Solids Handling	RPM	Phase	Wt.
5020PUUP	1/5	120	60	3.6	Thermoplastic	1 1/4"	10'	1/8"	3450	1	8