

5025PTSP Sump Pumps

With a tough thermoplastic construction, the 5025PTSP can handle up to 30 gallons per minute.

Features:

- Split Capacitor Motor - 1/4 HP continuous duty, thermal protected
- Lifts water up to 25' of vertical height
- 10' power cord, 25' cords are available for an additional charge
- Large 1 1/4" or 1 1/2" discharge for high capacity pumping
- Clog resistant impeller
- Tethered float switch



See Pumps & Accessories Price List for Limited Warranty details.

Performance Curve

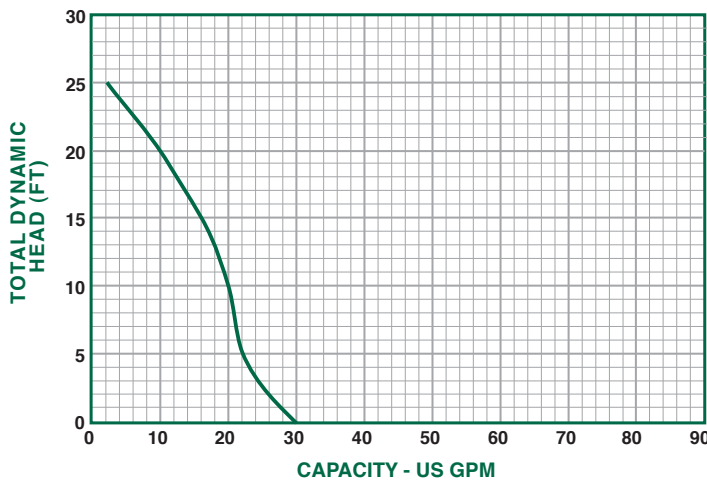

Dimensions

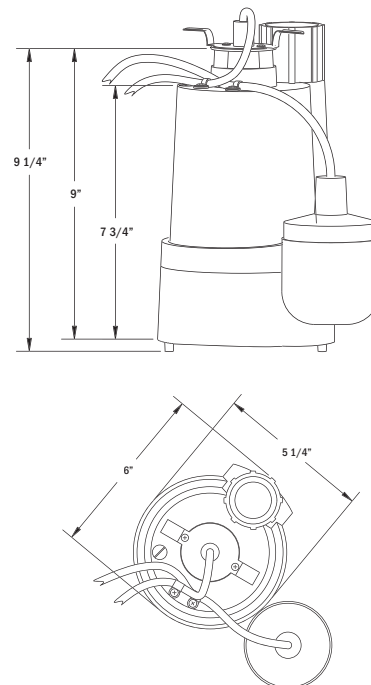

Performance

Model	Gallons per Minute in Feet					
	0	5	10	15	20	25
5025PTSP	30	22	20	16	9	2

Specifications

Model No.	HP	Volts	Hz	Amps	Construction	Discharge Size	Cord Length	Solids Handling	RPM	Phase	Wt.
5025PTSP	1/4	120	60	3.8	Thermoplastic	1 1/4" or 1 1/2"	10'	1/8"	3450	1	9