

SUBMERSIBLE SOLIDS HANDLING X-PROOF PUMP

Series: 4XBSE15044ADS

15 HP / 1750 RPM

Discharge: 4"

Spherical solids handling: 3"



Representative image.

DISCHARGE

4", 125 lb, flange horizontal.

LIQUID TEMPERATURE

104° F (40° C) continuous.

VOLUTE

Cast iron ASTM A-48 class 30.

MOTOR HOUSING

Cast iron ASTM A-48 class 30.

SEAL PLATE

Cast iron ASTM A-48 class 30.

IMPELLER

Design: 2 vane, open, with vanes on back side.

Material: cast iron ASTM A-48 class 30.

SHAFT

416 series stainless steel.

SQUARE RINGS

Buna-N.

PAINT

Air dry enamel, water based.

SEAL

Design: double, mechanical, oil filled chamber.

Material: silicon carbide outboard seal, carbon ceramic inboard seal, Buna-N elastomer and stainless steel hardware.

DIAPHRAGM

Buna-N.

HARDWARE

300 series stainless steel.

CORD ENTRY

25 ft of cord, epoxy sealed housing with secondary pressure gromet for sealing and strain relief.

BEARINGS

Upper: ball, single row, oil lubricated, for radial load.

Lower: ball, single row, oil lubricated, for radial and thrust load.

MOTOR

NEMA B, three phase, 460 volts, 60 Hz, 1750 RPM, air cooled. Explosion Proof, Class 1, Division 1, Group C & D, insulation Class F. Requires overload protection to be included in control panel.

MOISTURE SENSOR

Normally open (N/O) included, requires relay in control panel.

TEMPERATURE SENSOR

Normally closed (N/C) included, requires relay in control panel.

OPTIONAL EQUIPMENT

Additional cord, tungsten carbide seal, slide rail coupling (SRC-4).

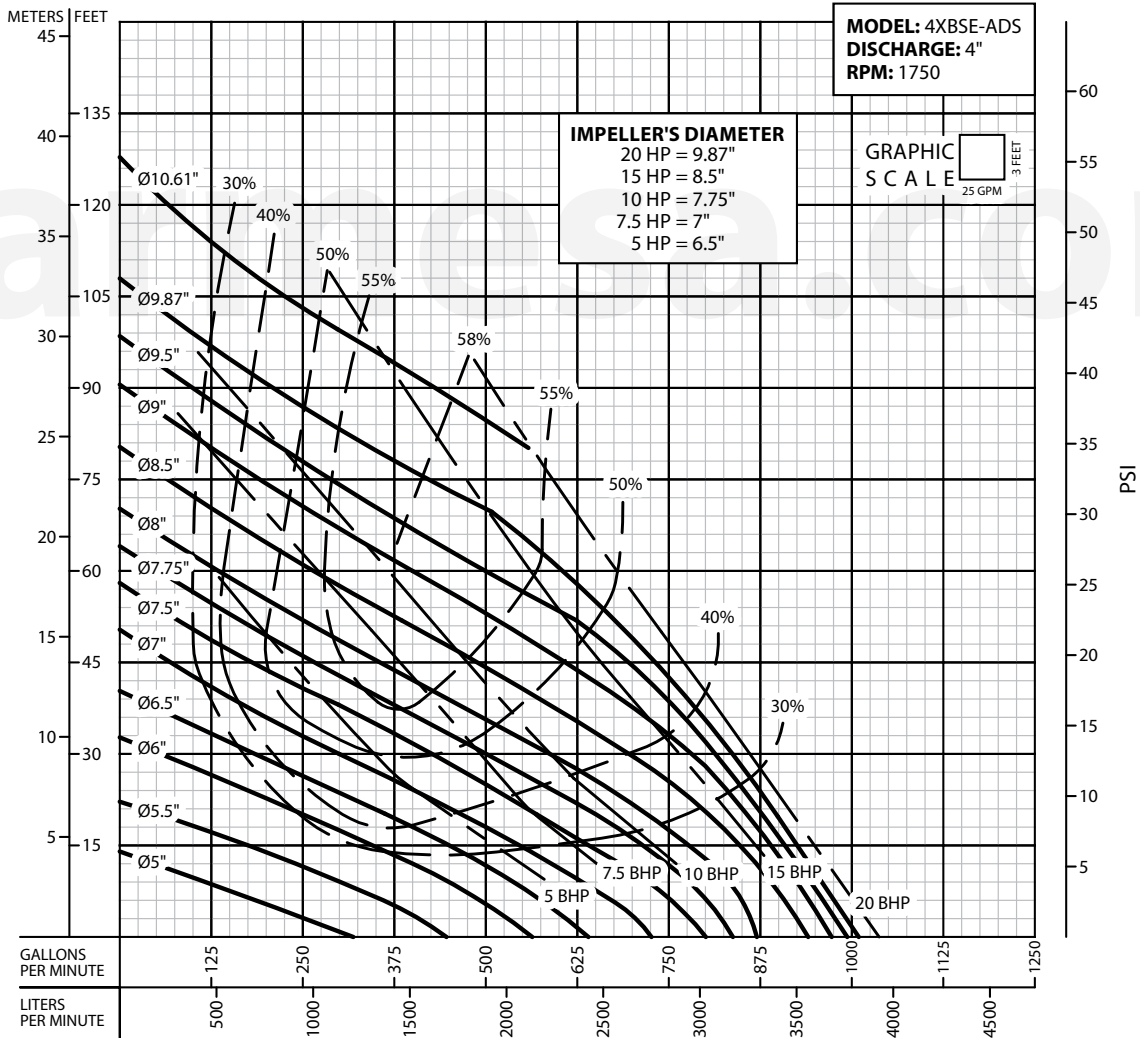
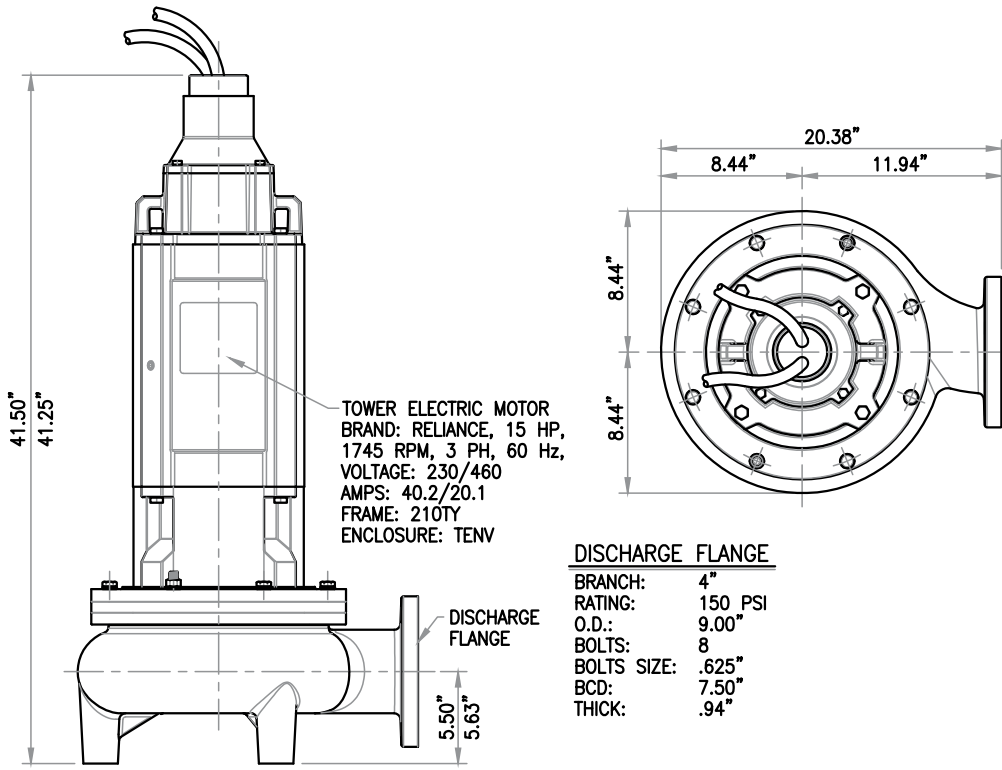

IMPORTANT!

1. Never use this pump to handle explosive liquids.
2. This pump is not approved to be used in swimming pools, recreational installations or any application where human contact may be common.
3. Pump may be operated "dry" for extended periods without damage to motor and/or seals.
4. Testing is performed with water specific gravity of 1.0 @ 68 °F (20 °C); other fluids may vary performance.