

# SLIDE RAIL COUPLING SRC-8

To be used with  
8BSE series pumps.



## LOCATION

This SRC-8 is designed for wet wells, tanks, or lift stations where it is necessary to remove a pump from service and reinstall the pump without maintenance personnel entering the pit to unbolt the pump flanges.

## STATIONARY ELBOW

Cast iron ASTM A-48 class 30.

## MOVABLE FITTING

Ductile iron ASTM A-536.

## GUIDERAIL CAP

**Bracket:** 304 stainless steel.

**Plugs:** rubber and steel.

## HARDWARE

300 series stainless steel.

## GASKETS

Rubber.

## PAINT

Air dry enamel, water based.

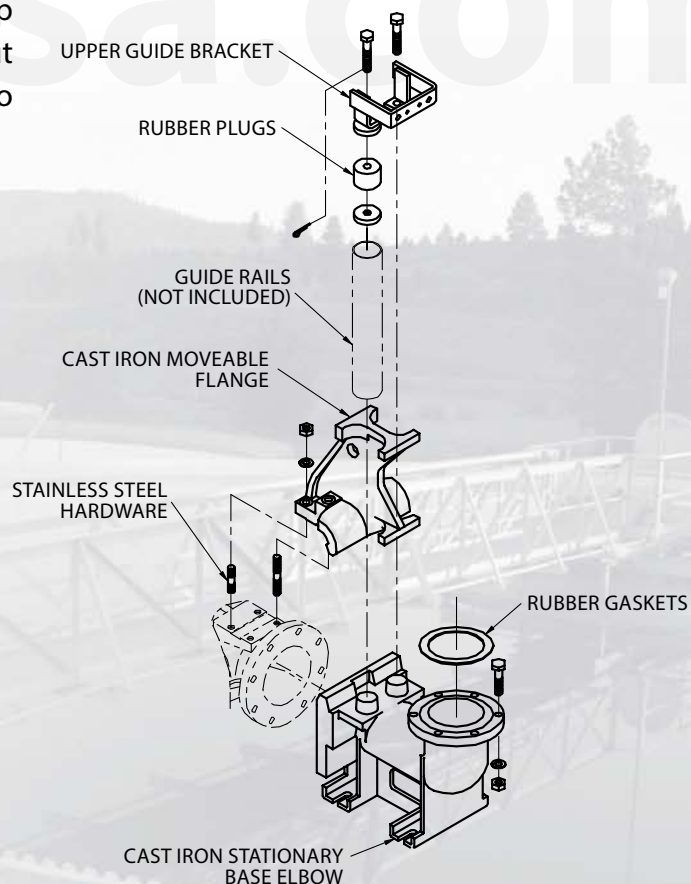

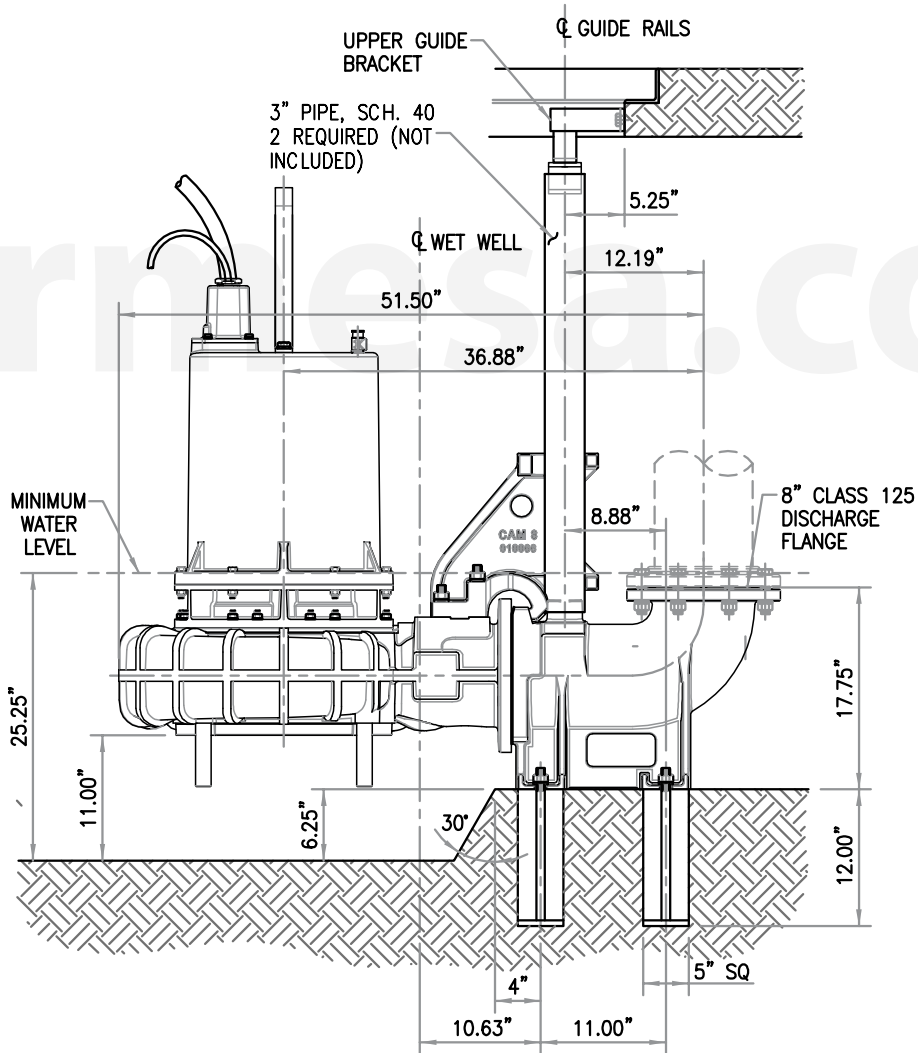
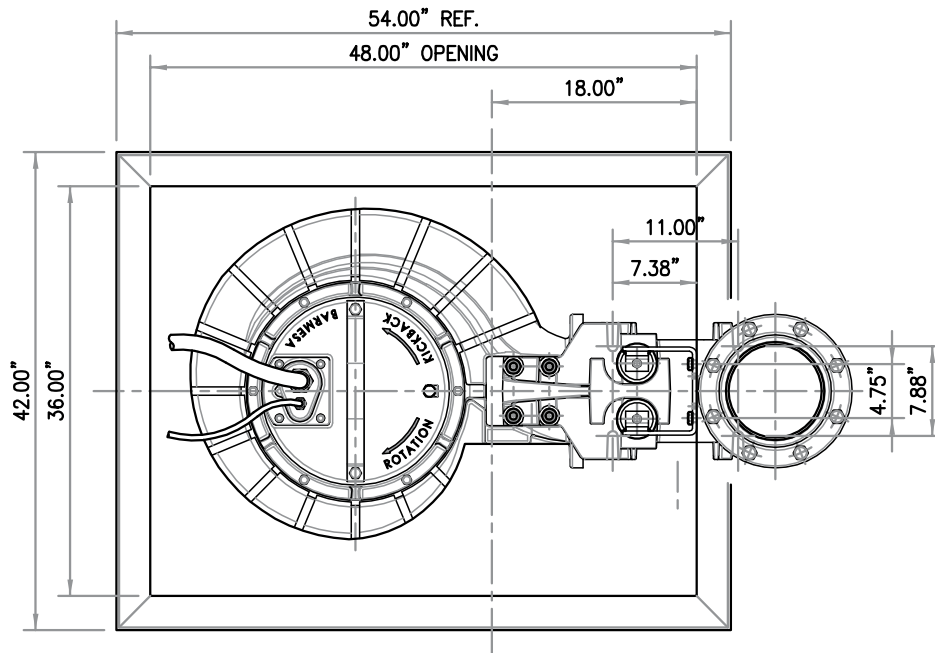

MODEL	PART No.	SIZE	RAILS	COUPLING	WEIGHT (pounds)
SRC8	62170807	8"	3"	w/ upper guide bracket	301