

BSP90MU

6" x 6"

Universal Drive



IMPORTANT! - Read all instructions in this manual before operating or servicing a pump.

Before installation, read the following instructions carefully. Failure to follow instruction and safety information could cause serious bodily injury, death and/or property damage. Each Barmesa product is carefully inspected to insure proper performance. Closely following these instructions will eliminate potential operating problems, assuring years of trouble-free service.

⚠ DANGER "Danger" indicates an imminently hazardous situation which, if not avoided, WILL result in death or serious injury.

⚠ WARNING "Warning" indicates an imminently hazardous situation which, if not avoided, MAY result in death or serious injury.

⚠ CAUTION "Caution" indicates a potentially hazardous situation which, if not avoided, MAY result in minor or moderate injury.

IMPORTANT! - Barmesa Pumps is not responsible for losses, injury or death resulting from failure to observe these safety precautions, misuse, abuse or misapplication of pumps or equipment.

⚠ ALL RETURNED PRODUCTS MUST BE CLEANED, SANITIZED, OR DECONTAMINATED PRIOR TO SHIPMENT, TO INSURE EMPLOYEES WILL NOT BE EXPOSED TO HEALTH HAZARDS IN HANDLING SAID MATERIAL. ALL APPLICABLE LAWS AND REGULATIONS SHALL APPLY.

Bronze/brass and bronze/brass fitted pumps may contain lead levels higher than considered safe for potable water systems. Lead is known to cause cancer and birth defects or other reproductive harm.

Various government agencies have determined that leaded copper alloys should not be used in potable water applications. For non-leaded copper alloy materials of construction, please contact factory.

⚠ WARNING Installation and servicing is to be conducted by qualified personnel only.

⚠ WARNING Operation against a closed discharge valve will cause premature bearing and seal failure on any pump, and on end suction and self priming pump the heat build may cause the generation of steam with resulting dangerous pressures. It is recommended that a high case temperature switch or pressure relief valve be installed on the pump body.

⚠ WARNING Do not pump hazardous materials (flammable, caustic, etc.) unless the pump is specifically designed and designated to handle them.

⚠ Always wear eye protection when working on pumps. Do not wear loose clothing that may become entangled in moving parts.

⚠ Keep clear of suction and discharge openings. Do not insert fingers in pump with power connected; the rotating cutter and/or impeller can cause serious injury.

⚠ DANGER Pumps build up heat and pressure during operation. Allow time for pumps to cool before handling or servicing the pump or any accessory items associated with or near the pump.

⚠ WARNING Do not exceed manufacturers recommended maximum performance, as this could cause the motor to overheat.

⚠ CAUTION Make sure lifting handles are securely fastened each time before lifting. Do not operate pump without safety devices in place. Always replace safety devices that have been removed during service or repair. Secure the pump in its operating position so it can not tip over, fall or slide.

⚠ WARNING If Engine driven, never operate in an enclosed building or area where exhaust gases can accumulate. Never operate near a building where exhaust gases can seep inside. Never operate in a pit or sump without making provisions for adequate ventilation.

⚠ WARNING Do not breathe exhaust fumes when working in the area of the engine. (Exhaust gases are odorless and deadly poison.)

⚠ WARNING Allow exhaust system to cool before touching.

⚠ Never add fuel to the tank while the engine is running. Stop engine and allow to cool. Do not smoke while refueling the engine and do not refuel near open flame.

⚠ WARNING Carefully read instruction manuals supplied by engine manufacture before attempting to assemble, operate or service the engine or any part. The "WARNING" statements indicate potentially hazardous conditions for operator or equipment.

SUCTION:	6" NPT, female flange.
DISCHARGE:	6" NPT, female flange.
SPHERICAL SLD HNDLG:	1¼"
LIQUID TEMPERATURE:	160°F (71°C) max.
VOLUTE:	Cast iron ASTM A-48 class 30.
BODY:	Cast iron ASTM A-48 class 30.
PEDESTAL:	Cast iron ASTM A-48 class 30.
IMPELLER:	4 vanes, semi-open type, dynamically balanced. Cast iron ASTM A-48 class 30.
SHAFT:	Steel.
SHAFT SLEEVE:	Steel.
O-RINGS:	Buna-N.
PAINT:	Air dry enamel, water based.
SEAL:	Single mechanical with lip seal, water lubricated. Ceramic stationary part, carbon ring seal and exclusion in the rotating part. Buna-N elastomer and stainless steel spring.
CHECKVALVE:	Flap-neoprene, weight of steel.
HARDWARE:	Steel.
BEARING-DRIVE END:	Double row, ball, grease lubricated.
BEARING-PUMP END:	Single row, ball, grease lubricated.
SHIMSET:	Stainless steel.
STRAINER:	Steel.

barmesapumps.com

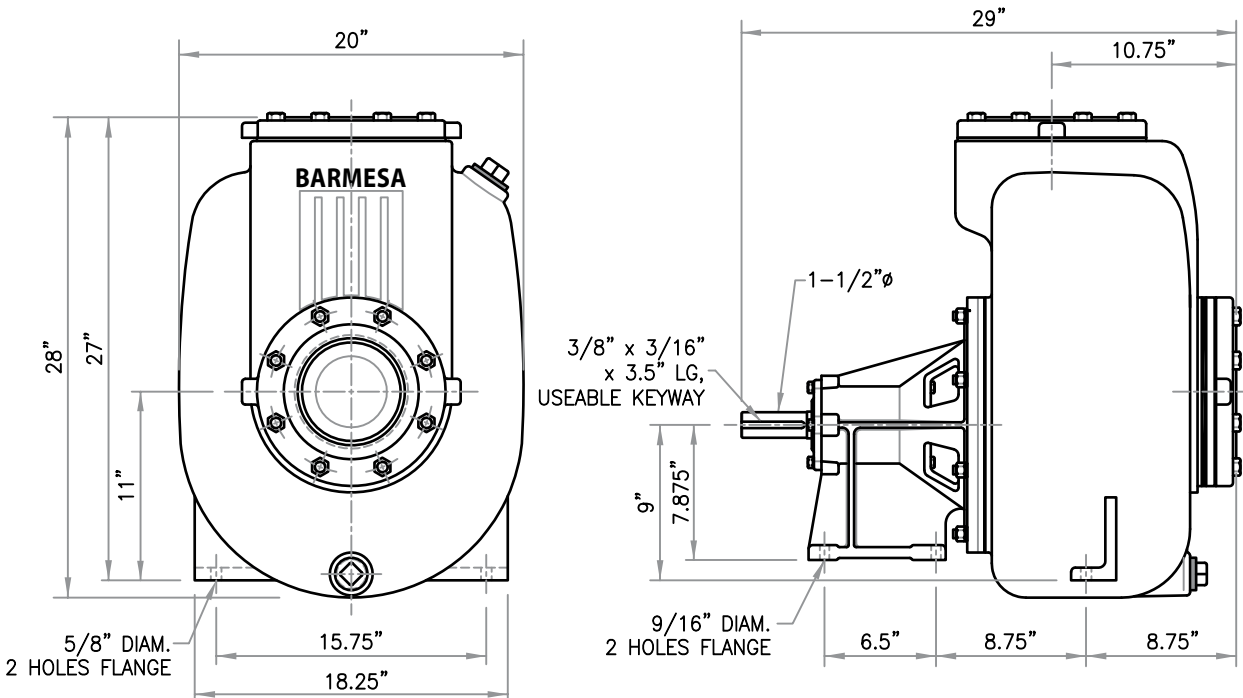

► Receiving inspection

Upon receiving the pump, it should be inspected for damage or shortages. If damage has occurred, file a claim immediately with the company that delivered the pump. If the manual is removed from the packaging, do not lose or misplace.

► Storage

Any product that is stored for a period longer than six (6) months from the date of purchase should be bench tested prior to installation. A bench test consists of, checking the impeller to assure it is free turning and a run test to assure the motor (and switch if provided) operate properly.

► Controls

Manual models require a separate approved pump control device or panel for automatic operation. Be sure the electrical specification of the control selected properly match the electrical specifications of the pump.

► Installation

Location:

The pump should be located as near as possible to the liquid to be pumped and in no case should the pump be more than 25 feet above the surface of the liquid supply. The pump should always be as level as possible.

All pump units rotate clockwise when looking from the driven end of the pump. The impellers are threaded on the shaft and it is necessary to slide one half of the flexible coupling back when checking rotation in order to eliminate the possibility of unscrewing the impeller and damaging the pump. **NOTE:** Where impellers thread on pump shaft, never check the direction of electric motor rotation without first disconnecting flexible coupling.

Locate the pump on a firm footing to make sure the pump will not move due to vibration. Flex coupled and V-belt driven units should be permanently grouted onto a cement foundation. The pumps should be level to provide favorable operating conditions. In addition, the flexible coupling should be realigned after grouting in order to eliminate excessive wear on the coupling.

Allow a minimum of 18 inches in front of the pump case cover or hatch cover to permit easy removal and access to the interior of the pump. On belt driven units, allow a minimum of 10 inches at the shaft end to permit easy removal of the pedestal or rotating cartridge.

Suction system:

It is advisable to use a suction line of the same size as the pump port size. All horizontal suction lines should slope up to the pump to avoid trapped air pockets. An adjustable stand, pipe clamp or floor flange must be installed to support the weight of the suction line. Using a smaller suction line than the pump port size can cause internal damage to the pump.

The suction line must not have holes, even small holes. The smallest air leak in the suction line may prevent the pump from priming. Coat all threaded connections in the suction line with pipe thread compound to insure an air tight joint. In addition, suction flanges should be pulled up tight to prevent air leaks.

⚠ CAUTION THIS PUMP SHOULD NOT BE OPERATED WITHOUT A STRAINER ON THE END OF THE SUCTION LINE TO PREVENT STICKS. STONES, RAGS AND OTHER FOREIGN MATTER FROM BEING DRAWN INTO THE IMPELLER. THE STRAINER SHOULD BE CLEANED REGULARLY TO INSURE FULL FLOW.

Discharge system:

Connect discharge hose or pipe to the side outlet on the discharge tee or to the discharge elbow.

Driver:

Read engine or motor manufacturer's instruction book.

Pump Lubrication:

The only part of the pump requiring lubrication is the bearing housing. The impeller and shaft seal are lubricated by the liquid being pumped and need no other lubrication.

The bearing housing is factory filled with 90 weight oil, for bearing lubrication. The oil level in the bearing housing should be periodically checked. This is accomplished by removing the oil dip stick and checking oil level shown on it. If oil is required, add through the dip stick hole.

⚠ CAUTION DO NOT OPERATE PUMP WITHOUT LIQUID IN PUMP BODY AS OPERATING DRY WILL RESULT IN DAMAGE TO THE SEAL.

► **Operation**

Priming:

Remove the priming plug(s) (35) in the top of the pump body (6), and fill the pump body completely with liquid as free of solids as possible. In freezing weather, the pump should be primed with warm water, if possible, to prevent any damage that may be caused by ice films within the pump.

Starting:

After completion of procedures outlined in the past sections, the pump is then ready for operation. Start pump by applying power to motor or by starting engine as outlined in the **ENGINE or MOTOR INSTRUCTION MANUAL**.

Shutdown:

Operation may be discontinued by stopping the engine as outlined in the **ENGINE MANUAL** or by disconnecting electric power if motor driven. When the pump has been operating in freezing weather or in liquid containing a considerable amount of solids, it is advisable to drain the pump body by removing drain plug (6) and flushing the solids out of the body. Replace the drain plug.

Restart:

At each subsequent start, particularly if the pump has been drained, the priming liquid level should be checked since the pump is self-priming only when the body is full of liquid.

► **Service & Repair**

Check Valve Service:

To clean out or repair check valve, disconnect suction piping. Remove hex nuts (23) companion flange (3), flange gasket (33) and suction flange (2). **DO NOT PRY ON FLANGE** but rather bump off with a block of wood and a hammer.

Pull off gasket (34) together with weights (5) and (4), round head screw (30), lock washer (29) and hex nut. Examine and replace any parts showing wear or damage. When replacing gasket and weight assembly onto pump body make sure that HINGE section of gasket (34) is at TOP and that LARGE weight is on PUMP SIDE of gasket.

Body and Impeller Service:

To clean out or repair the body (6), or impeller (7), disconnect suction and discharge piping. Remove hex nuts (25) and pull body (6) from bearing pedestal (1). This will expose the body (6), body gaskets (31) and (32) and impeller (7) for clean out or replacement. Clean and examine body (6), body gaskets (31) and (32), and impeller (7), replace if required. When impeller (7) needs replaced, unscrew impeller from shaft. The impeller is screwed onto the shaft with right hand thread, and to break loose use a block of wood against a vane and strike with a hammer.

Shaft Seal Service:

To examine or replace shaft seal (16), remove body and impeller as outlined in the previous paragraph. Remove impeller shims (18) and (19) and seal spring holder, spring and rotating member of seal from shaft (12). All of the components of the shaft seal are now exposed for examination. If any part shows wear or damage, replace entire shaft seal assembly.

⚠ CAUTION HANDLE SEAL PARTS WITH EXTREME CARE. DO NOT SCRATCH OR MAR LAPPED FACES.

If stationary member needs replaced, remove hex nuts (25) and pull seal plate (9) together with stationary member from bearing housing (1). Press used stationary member out of the seal plate (9).

Lightly oil seal cavity in seal plate (9) and ring of stationary member. Replace seal plate (9) onto bearing housing (1). Lightly oil shaft (12) and press stationary member over shaft and into seal plate (9). Lightly oil shaft and inner surface of rotating member, with lapped surface facing bearing housing, slide rotating member onto shaft (12) until lapped faces of rotating member and stationary member are together. Replace spring and spring holder and reassemble remainder of pump.

When the impeller (7) is removed, the following parts also come off; shims (18) and (19), spring holder, spring and rotating members of shaft seal (16).

At reassembly make sure to use a combination of impeller shims (18) and (19) and body gaskets (31) and (32) to result in an impeller-to-body clearance of approximately 0.015".

Shaft and Bearing Service:

Remove pump body, impeller, shaft seal and as outlined previous sections.

Remove cap screws (28) and pull front bearing cap (8) together with grease seal (17) from bearing pedestal (1). Remove cap screws (28) and pull rear bearing cap (8) together with grease seal (17) from bearing pedestal (1). Remove bearing shims (20) and (21). Tap on drive end of shaft (12) with a block of wood and a hammer, driving the shaft (12) together with the complete front bearing (14) and the roller and cone of the back bearing (15) out of the pedestal (1). Examine shaft, bearings and grease seals and replace if required.

If bearings are to be replaced, press bearing parts from shaft and remove bearing cup from pedestal by tapping with a drift and a hammer. If grease seals are to be replaced, press used seals out of bearing caps and replace. Press new seals into bearing caps with patent number side out.

Place bearing cup for back bearing (15) into drive end of pedestal (1). Be certain that the wide end of the cup taper is facing the outside of the bearing housing. Press the cone and roller of back bearing (15) onto drive end of shaft (12) seating it snug against the shaft shoulder, with the taper running toward impeller end of shaft. Press complete front bearing (14) onto impeller end of shaft (12) seating it snug against the shaft shoulder with the taper running toward drive end of shaft.

Place assembled shaft and bearings into pedestal (1) key end first. Bring the front bearing (15) into position and press in place. If tight, use a sleeve and hammer to tap into position. Replace back bearing cap (8) and grease seal (17). **Do not** seat bearings too tight but make sure that a snug fit is insured, yet permitting free movement of shaft in bearings. Replace front bearing cap (8) and grease seal (17) using required number of shims (20) to allow for a 0.005" shaft end play. Replace slinger onto shaft (12) before reassembling remainder of pump.

Figure 1

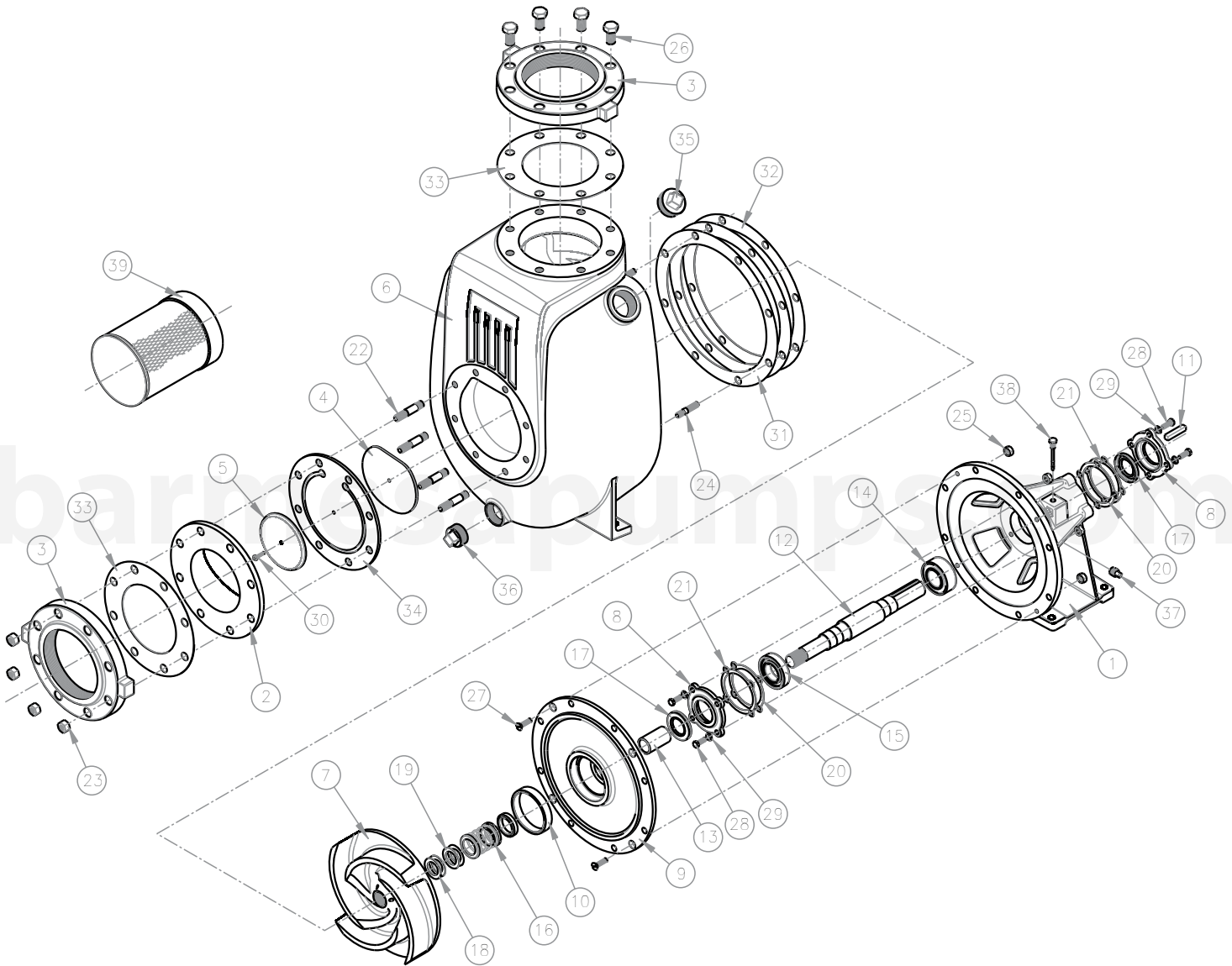

For Repair Part Please supply: Model Number and Serial as shown on Name Plate, and Part Description and Part Number as shown on Parts List.

ITEM	PART No.	DESCRIPTION	QTY.
1	03040006	PEDESTAL	1
2	03050007	SUCTION FLANGE	1
3	03060008	6" FLANGE	2
4	03080008	WEIGHT, LARGE	1
5	03080009	WEIGHT, SMALL	1
6	03090008	BODY	1
7	03140008	IMPELLER	1
8	03170002	BEARING CAP	2
9	03180010	SEAL PLATE	1
10	30400342	GREASE SEAL	1
11	30400634	KEY 3/8" x 3/8" x 3"	1
12	30400715	SHAFT	1
13	30400811	SHAFT SLEEVE	1
14	31020014	BEARING 3208	1
15	31020013	BEARING 6208	1
16	31030132	SEAL 1½" Ø T21	1
17	31150002	GREASE SEAL # 15730	2
18	91010135	SHIM # 1161	2
19	91010136	SHIM # 1162	2
20	91010150	SHIM #5067	2
21	91010151	SHIM #5069	2
22	91010315	STUD 5/8" x 3¼"	8
23	91010416	HEX NUT 5/8"	8
24	91010311	STUD ½" x 2½"	8
25	91010415	HEX NUT ½"	8
26	91010291	CAP SCREW 3/4" x 1½"	8
27	91010205	FLAT HD SCREW 3/8" x 1½"	4
28	91010242	CAP SCREW 3/8" x 1"	8
29	91010012	LOCKWASHER 3/8"	8
30	91010407	HEX HD SCREW 1/4" x 1" AND HEX NUT 1/4" x1	1
31	92010152	GASKET	1
32	92010153	GASKET	2
33	92010159	6" GASKET	2
34	92010215	CHECK VALVE GASKET # 1729	1
35	93010147	PIPE PLUG 2"	1
36	93010145	PIPE PLUG 1½"	1
37	93010143	PIPE PLUG 1/4"	1
38	30400851	DIP STICK ASSY	1
39	31030085	6" STRAINER	1

For Repair Part Please supply: Model Number and Serial as shown on Name Plate, and Part Description and Part Number as shown on Parts List.



Always disconnect the pump from the electrical power source before handling.

If the system fails to operate properly, carefully read instructions and perform maintenance recommendations.

Symptom	Possible Cause(s)	Corrective Action
Little or no discharge and unit will not prime	<ol style="list-style-type: none"> 1. Casing not filled with water 2. Total head too high 3. Suction head higher than pump designed for 4. Impeller partially or completely plugged 5. Hole or leak in suction line 6. Foot-valve too small 7. Impeller damaged 8. Foot-valve or suction line not submerged deep enough in water; pulling air 9. Insufficient inlet pressure or suction head 10. Suction piping too small 11. Casing gasket leaking 12. Suction or discharge line valves closed 13. Piping is fouled or damaged 14. Clogged strainer or foot-valve 15. Incorrect engine speed 	<ol style="list-style-type: none"> 1. Fill pump casing. Using a foot-valve will extend pump life and facilitate immediate priming 2. Shorten suction head 3. Lower suction head, install foot-valve and prime. 4. Disassemble pump and clean out impeller 5. Repair or replace suction line 6. Match foot-valve to piping or install one size larger foot-valve 7. Disassemble pump and replace impeller 8. Submerge lower in water 9. Increase inlet pressure by adding more water to tank or increasing back pressure by turning gate valve on discharge line partially closed position 10. Increase pipe size to pump inlet size or larger 11. Replace 12. Open 13. Clean or replace 14. Clean or replace 15. Increase speed
Loss of suction after satisfactory operation	<ol style="list-style-type: none"> 1. Air leak in suction line 2. When unit was last turned off, water siphoned out of pump casing 3. Suction head higher than pump designed for 4. Insufficient inlet pressure or suction head 5. Clogged foot-valve, strainer, or pump 6. Defective wearplate(s) 	<ol style="list-style-type: none"> 1. Repair or replace suction line 2. Refill (reprime) pump casing before restarting 3. Lower suction head, install foot-valve and primer 4. Increase inlet pressure by adding more water to tank or increasing back pressure by turning gate valve on discharge line to partially closed position 5. Unclog, clear or replace as necessary 6. Replace
Pump overloads driver	<ol style="list-style-type: none"> 1. Total head lower than pump rating, unit delivering too much water 2. Specific gravity and viscosity of liquid being pumped different than the pump rating 3. Speed too high 	<ol style="list-style-type: none"> 1. Increase back pressure on pump by turning gate valve on discharge line to partially closed position that will not overload motor 2. Consult factory 3. Check and correct, lower speed
Pump vibrates and/or makes excessive noise	<ol style="list-style-type: none"> 1. Mounting plate or foundation not rigid enough 2. Foreign material in pump causing unbalance 3. Impeller bent 4. Cavitation present 5. Piping not supported to relieve any strain on pump assembly 	<ol style="list-style-type: none"> 1. Reinforce 2. Disassemble pump and remove 3. Replace impeller 4. Check suction line for proper size and check valve in suction line if completely open, remove any sharp bends before pump and shorten suction line 5. Make necessary adjustments
Pump runs but no fluid	<ol style="list-style-type: none"> 1. Faulty suction piping (air leak) 2. Pump located too far from fluid source 3. Gate valve closed 4. Clogged strainer 5. Fouled foot-valve 6. Discharge height too great 7. Fouled impeller 8. Faulty mechanical seal 	<ol style="list-style-type: none"> 1. Replace 2. Replace 3. Open 4. Clean or replace 5. Clean or replace 6. Lower the height 7. Clean or replace 8. Replace
Pump leaks at shaft	<ol style="list-style-type: none"> 1. Worn mechanical seal 2. Replacement seal not installed properly 	<ol style="list-style-type: none"> 1. Replace 2. Follow Maintenance instructions carefully

BARMESA PUMPS FACTORY WARRANTY

Barmesa Pumps warrants that products of our manufacture will be free of defects in material and workmanship under normal use and service for 18 months from date of manufacture or 12 months from installation date whichever occurs first. This warranty gives you specific legal rights, which vary from state to state.

This warranty is a limited warranty, and no warranty related claims of any nature whatsoever shall be made against Barmesa Pumps, until the ultimate consumer or his/her successor notifies us in writing of the defect and delivers the product and/or defective part(s) freight prepaid to our factory or nearest authorized service station as instructed by Barmesa Pumps. THERE SHALL BE NO FURTHER LIABILITY, WHETHER BASED ON WARRANTY, NEGLIGENCE OR OTHERWISE. PRODUCT SHALL BE EITHER REPLACED OR REPAIRED AT THE ELECTION OF BARMESA PUMPS. Guarantees relating to performance specifications provided in addition to the foregoing material and workmanship warranties on a product manufactured by Barmesa Pumps, if any, are subject to possible factory testing. Any additional guarantees, in the nature of certified performance specifications or time frame must be in writing and such writing must be signed by our authorized factory manager at time of order placement and/or at time of quotation. Due to inaccuracies in field testing and should a conflict arises between the results of field testing conducted by or for the user, Barmesa Pumps reserves the right to have the product returned to our factory for additional testing.

This warranty shall not apply when damage is caused by (1) improper installation, (2) improper voltage, (3) lightning, (4) excessive sand or other abrasive material, (5) corrosion build-up due to excessive chemical content or (6) uncontrollable acts of god. Any modification of the original equipment will also void the warranty. We will not be responsible for loss, damage or labor cost due to interruption of service caused by defective pumps, parts or systems. Barmesa Pumps will not accept charges incurred by others without our prior written approval.

This warranty is void if our inspection reveals the product was used in a manner inconsistent with normal industry practice and/or our specific recommendations. The purchaser is responsible for communication of all necessary information regarding the application and use of the product. UNDER NO CIRCUMSTANCES WILL WE BE RESPONSIBLE FOR ANY OTHER DIRECT OR CONSEQUENTIAL DAMAGES, INCLUDING BUT NOT LIMITED TO TRAVEL EXPENSES, CONTRACTOR FEES, UNAUTHORIZED REPAIR SHOP EXPENSES, LOST PROFITS, LOST INCOME, LABOR CHARGES, DELAYS IN PRODUCTION, IDLE PRODUCTION, WHICH DAMAGES ARE CAUSED BY ANY DEFECTS IN MATERIAL AND/OR WORKMANSHIP AND/OR DAMAGE OR DELAYS IN SHIPMENT. THIS WARRANTY IS EXPRESSLY IN LIEU OF ANY OTHER EXPRESS OR IMPLIED WARRANTY. No rights extended under this warranty shall be assigned to any other person, whether by operation of law or otherwise, without our prior written approval.

IMPORTANT!

If you have a claim under the provision of the warranty, contact Barmesa Pumps or your authorized Barmesa Pumps Distributor:
warranty@barmesapumps.com
www.barmesapumps.com



