

BARNES®

INSTALLATION MANUAL Simplex Sewage Package Systems

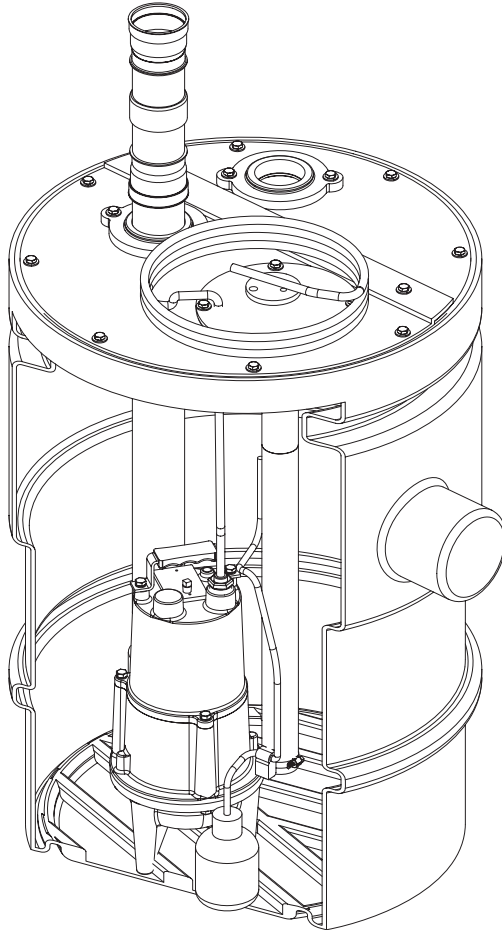

41 Gallon Basin Packages

IMPORTANT!

*Read all instructions in this manual before operating pump.
As a result of Crane Pumps & Systems, Inc., constant product improvement program,
product changes may occur. As such Crane Pumps & Systems reserves the right to
change product without prior written notification.*

CRANE[®]

A Crane Co. Company

PUMPS & SYSTEMS

420 Third Street
Piqua, Ohio 45356
Phone: (937) 778-8947
Fax: (937) 773-7157
www.cranepumps.com

83 West Drive, Bramton
Ontario, Canada L6T 2J6
Phone: (905) 457-6223
Fax: (905) 457-2650



Form No. 126898-Rev. E

ATTENTION SAFETY FIRST!

Please Read This Before Installing Or Operating Pump. This information is provided for **SAFETY and to PREVENT EQUIPMENT PROBLEMS**. To help recognize this information, observe the following symbols:



IMPORTANT! Warns about hazards that can result in personal injury or indicates factors concerned with assembly, installation, operation, or maintenance which could result in damage to the machine or equipment if ignored.

CAUTION ! Warns about hazards that can or will cause minor personal injury or property damage if ignored. Used with symbols below.

WARNING ! Warns about hazards that can or will cause serious personal injury, death, or major property damage if ignored. Used with symbols below.



Hazardous fluids can cause fire or explosions, burns or death could result.



Extremely hot - Severe burns can occur on contact.



Biohazard can cause serious personal injury.



Hazardous fluids can Hazardous pressure, eruptions or explosions could cause personal injury or property damage.



Rotating machinery Amputation or severe laceration can result.



Hazardous voltage can shock, burn or cause death.

Only qualified personnel should install, operate and repair pump. Any wiring of pumps should be performed by a qualified electrician.



WARNING ! - To reduce risk of electrical shock, pumps and control panels must be properly grounded in accordance with the National Electric Code (NEC) or the Canadian Electrical Code (CEC) and all applicable state, province, local codes and ordinances.



WARNING! - To reduce risk of electrical shock, always disconnect the pump from the power source before handling or servicing. Lock out power and tag.

Prevent large articles of clothing, large amounts of chemicals, other materials or substances such as are uncommon in domestic sewage from entering the system.

During power black-outs, minimize water consumption at the home(s) to prevent sewage from backing up into the house.

Always keep the shut-off valve completely open when system is in operation (unless advised otherwise by the proper authorities). Before removing the pump from the basin, be sure to close the shut-off valve. (This prevents backflow from the pressure sewer.)

Keep the control panel locked or confined to prevent unauthorized access to it.

If the pump is idle for long periods of time, it is advisable to start the pump occasionally by adding water to the basin.



CAUTION! Pumps build up heat and pressure during operation-allow time for pumps to cool before handling or servicing.



WARNING! - **DO NOT** pump hazardous materials (flammable, caustic, etc.) unless the pump is specifically designed and designated to handle them.



Do not block or restrict discharge hose, as discharge hose may whip under pressure.



WARNING! - **DO NOT** wear loose clothing that may become entangled in the impeller or other moving parts.



WARNING! - Keep clear of suction and discharge openings. **DO NOT** insert fingers in pump with power connected.

Make sure lifting handles are securely fastened each time before lifting. Do not operate pump without safety devices in place. Always replace safety devices that have been removed during service or repair.

Do not exceed manufacturers recommendation for maximum performance, as this could cause the motor to overheat.

Secure the pump in its operating position so it can not tip over, fall or slide.

Cable should be protected at all times to avoid punctures, cut, bruises and abrasions - inspect frequently.



Never handle connected power cords with wet hands.



To reduce risk of electrical shock, all wiring and junction connections should be made per the NEC or CEC and applicable state or province and local codes. Requirements may vary depending on usage and location.



Submersible Pumps are not approved for use in swimming pools, recreational water installations, decorative fountains or any installation where human contact with the pumped fluid is common.

Do not remove cord and strain relief. Do not connect conduit to pump.

Products Returned Must Be Cleaned, Sanitized, Or Decontaminated As Necessary Prior To Shipment, To Insure That Employees Will Not Be Exposed To Health Hazards In Handling Said Material. All Applicable Laws And Regulations Shall Apply.



Bronze/brass and bronze/brass fitted pumps may contain lead levels higher than considered safe for potable water systems. Lead is known to cause cancer and birth defects or other reproductive harm. Various government agencies have determined that leaded copper alloys should not be used in potable water applications. For non-leaded copper alloy materials of construction, please contact factory.



IMPORTANT! - Crane Pumps & Systems, Inc. is not responsible for losses, injury, or death resulting from a failure to observe these safety precautions, misuse or abuse of pumps or equipment.

Other brand and product names are trademarks or registered trademarks of their respective holders.

® Barnes is a registered trademark of Crane Pumps & Systems Inc.

4/07

BARNES®

USER GUIDE

Congratulations on your purchase of a Barnes pump system. With proper care and by following a few simple guidelines your grinder pump will give you many years of dependable service.

Use and Care

The pump station is designed to handle routine, domestic sewage. Solid waste materials should be thrown in the trash. While your station is capable of accepting and pumping a wide range of materials, regulatory agencies advise that the following items should not be introduced into any sewer either directly or through a kitchen waste disposal:

- Glass
- Metal
- Diapers
- Socks, rags or cloth
- Plastic objects (e.g., toys, utensils, etc.)
- Sanitary napkins or tampons

In addition you must **NEVER** introduce into any sewer:

- Explosives
- Flammable Material
- Lubricating Oil and/or Grease
- Strong Chemicals
- Gasoline

Power Failure

Your pump cannot dispose of wastewater or provide an alarm signal without electrical power. If electrical power service is interrupted, keep water usage to a minimum.

Warranty

Your pump is furnished with a warranty against defects in material or workmanship. A properly completed

Start-Up/Warranty Registration form must be on file at the Barnes factory in order to activate your warranty. In addition your pump must be installed in accordance with the installation instructions.

If you have a claim under the provisions of the warranty, contact your local Barnes Distributor.

When contacting your representative for service, please include your station serial number, pump model number, and pump serial number.

For future reference, record the following information:

Station Serial No: _____

Pump Model No: _____

Pump Serial No: _____

Local Distributor: _____

Distributor Telephone: _____

PUMP SPECIFICATIONS:

TEMPERATURE 77°F (25°C) Continuous
IMPELLER 2 Vane, open or vortex
SOLIDS HANDLING 2" (51mm) spherical
PAINT Air dry enamel
SEAL Single Mechanical, oil-filled reservoir
CABLE ENTRY 15 ft. (6m) quick disconnect cord
 w/ plug on 120 volt and 240 volt, 1
 phase, pressure grommet for sealing
 and strain relief
UPPER BEARING..... Single row, ball design, oil lubrication,
 radial load
LOWER BEARING..... Single row, ball design, oil lubrication,
 radial & thrust load
MOTOR NEMA L torque curve, oil-filled,
 squirrel cage induction, Class B
 insulation
SINGLE PHASE..... Permanent Split Capacitor (PSC)
 includes overload protection in motor
FLOAT Wide angle, PVC, mechanical,
 normally open 15 ft. (6m), cable with
 Piggy-back plug
BASIN Polyethylene Basin
 20" x 30" or 25" x 24"
INLET FITTING..... For 4" (102mm) Sch. 40 inlet

COVER Structural Foam, grommets for
 2" (51mm) vent & discharge, cord
 grommet, cover gasket and hardware;
 optional access cover
CHECK VALVE..... 2" (51mm) vertical, Sch. 40 discharge
 pipe compression

DESCRIPTION

Simplex Sewage package systems are good for residences, commercial and small industrial sewage or sump applications. Designed to handle nonexplosive and noncorrosive liquids, wastes from lavatories, laundry tubs, floor drains and water closets. Pumps push the water from below ground up to where normal drainage will handle it. The package system shall NOT be installed in locations classified as hazardous in accordance with the United States National Electrical Code (NEC), ANSI/NFPA 70 and shall be vented in accordance with local plumbing codes.

NOTE

Pre-Assembled units contain water soluble packing inside. There is no need to remove it.

Pump Material

Models	Volute	Motor Housing	Seal Plate	Impeller	Shaft	Square Rings	Hardware	Seal
SE411 SE421 SEV412	Cast Iron	Cast iron	Cast Iron	Cast Iron	416 SS	Buna-N	300 Series SS	Silicon Carbide/ Buna-N

Models	HP	Volt	Ph	NEMA Start Code	Full Load Amps	Cord Size	Cord Type	Cord O.D. Inches (mm)	Winding Resistance Main - Start
SE411	.4	115	1	C	12.0	14/3	SJTOW	.375 (9.53)	2.14 - 30.5
SE421	.4	230	1	C	6.2	14/3	SJTOW	.375 (9.53)	5.45 - 16.7
SEV412	.5	115	1	H	10.5	14/3	SJTOW	.375 (9.53)	3.50 - 43.0

41 Gallon Sewage Station - Configuration Matrix

Configuration	Tank Type		Configuration		Pump			Voltage **	
	20" Dia. x 30" Dp.	25" Dia. x 24" Dp.	Basin Kit *	Pre-Assembled	SEV412	SE411	SE421	120V	230V
126902	X		X					X	
126904	X		X						X
126908		X	X					X	
126910		X	X						X
126914	X			X	X				
126915	X			X		X			
126916	X			X			X		
126920		X		X	X				
126921		X		X		X			
126922		X		X			X		

* Basin Kits are less the pump. A pump must be ordered separately.

** The voltage selected is derived from the pump specified.

Basins

inches
(mm)

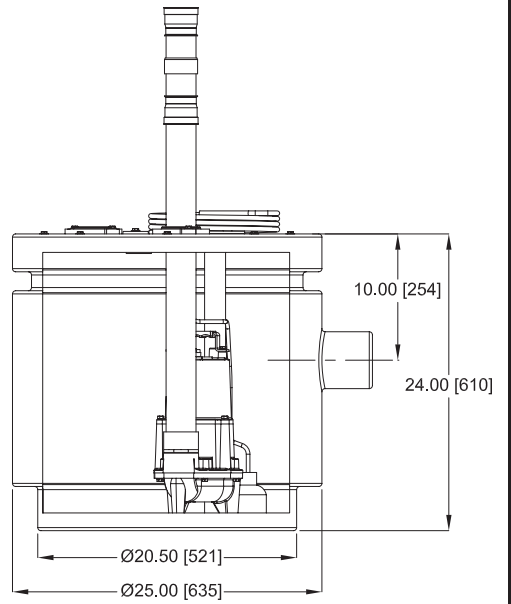
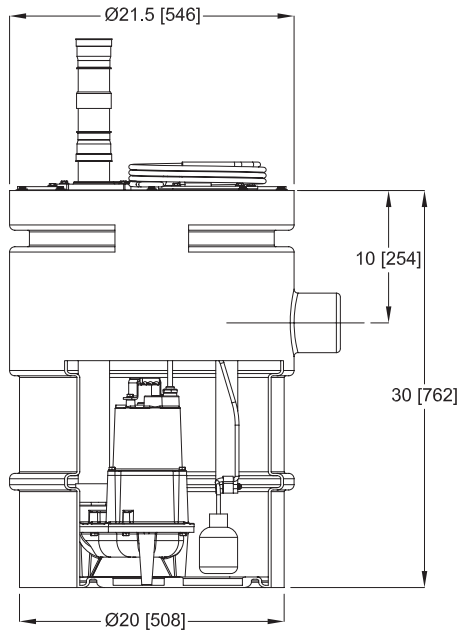
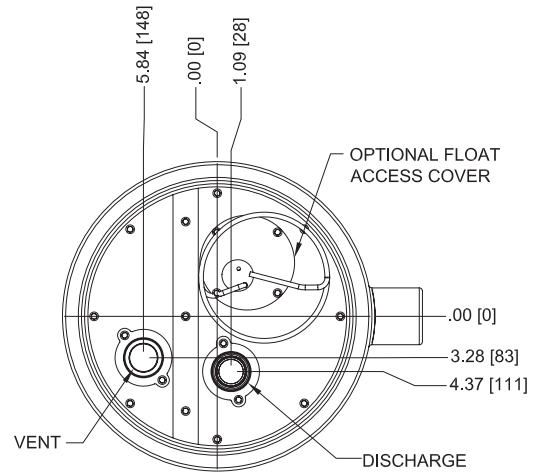
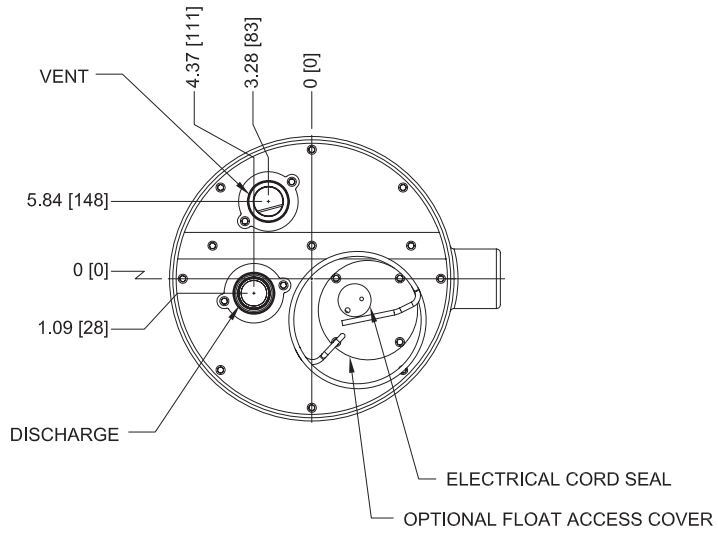

Unpacking

Upon receiving the pump, it should be inspected for damage or shortages. If damage has occurred, file a claim immediately with the carrier that delivered the pump. If the manual is removed from the packaging, do not lose or misplace.

Storage

Short Term - Pumps are manufactured for efficient performance following short inoperative periods in storage. For best results, pumps can be retained in storage, as factory assembled, in a dry atmosphere with constant temperatures for up to six (6) months.

Long Term - For storage of six (6) months, to twenty-four (24) months, the units should be stored in a temperature controlled area, a roofed over walled enclosure that provides protection from the elements (rain, snow, wind-blown dust, etc.), and whose temperature can be maintained between +40° F and +120° F. If extended high humidity is expected to be a problem, all exposed parts should be inspected before storage and all surfaces that have the paint scratched, damaged, or worn should be recoated with a water base, air dry enamel paint. All surfaces should then be sprayed with a rust-inhibiting oil.

Pump should be stored in its original shipping container. On initial start up, rotate impeller by hand to assure seal and impeller rotate freely.

If it is required that the pump be installed and tested before the long term storage begins, such installation will be allowed provided:

1. The pump is not installed under water for more than one (1) month.
2. Immediately upon satisfactory completion of the test, the pump is removed, thoroughly dried, repacked in the original shipping container, and placed in a temperature controlled storage area.

Installation

The basin should be located at the lowest point in the basement (or bottom floor) below floor level. The bottom of the basin should be level for proper pump operation.

Install 4" PVC schedule 40 Inflow pipe (supplied by contractor) into flexible pipe fitting. The recommended level should not drop below the top of the motor housing. Finish connecting discharge piping and vent piping.

Typical Installation with Wide Angle Level Control

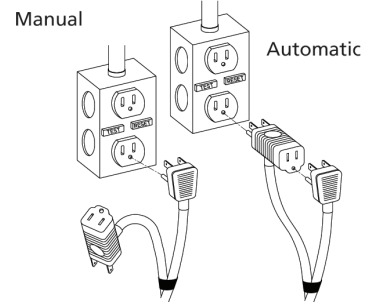
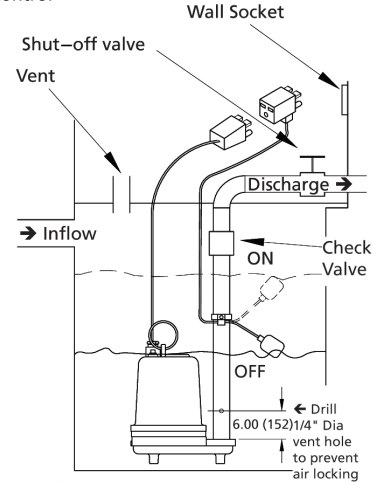

Figure 6 12 vol with GFCI

Automatic - Plug float cord into outlet, then plug pump cord into float cord.

Manual - Plug pump cord directly into outlet.

Level Controls

Figure 4 shows a typical installation for a level control mounted to the discharge piping with a piggy-back plug.



Never work in the sump with the power ON.

1. Level controls are factory set for a pumping differential of 9". If that is the cycle desired, simply circle the discharge pipe with the pipe mounting strap, feed the end through and tighten. Be certain that the level control can not hang up or foul in it's swing.
2. If a higher pump differential is needed, grip the cord near the neck of the float, then using the other hand, exert a steady force on the lower edge of the cable clamp. The cable clamp should slide up to the new pivot point.

The Basin

In Ground Installation of Basins

- A. **Excavation:** Excavate the hole as small as possible, with a minimum recommended 8" diametrical clearance around the tank. Never place the basin directly in contact with rocks or other sharp objects. Place only fine, 1/8" to 3/4" pea gravel or 1/8" to 1/2" washed, crushed stone as bedding between the basin and the hole walls. Do not use sand or native soil as backfill. Properly compact underneath the basin to provide a solid, level base that can support the weight of the filled basin. It is recommended that the top lip of the basin be level with the finished floor.
- B. **Initial Backfill:** Only fine, 1/8" to 3/4" pea gravel or 1/8" to 1/2" washed, crushed stone should be used around the bottom of the basin to hold it in place. Do not use sand or native soil as backfill. Make the inlet connection as required for your basin.
- C. **Inlet Connection:** The basins have a 4" inlet molded to the side of the tank. This inlet is sized to accept a 4" no-hub type coupling. Connect the gravity drainage line from the fixtures to this hub.
- D. **Final Backfill:** Large rocks, clods, and foreign objects should be kept out of the backfill material. Only fine, 1/4" to 3/4" pea gravel, or 1/8" to 1/2" washed, crushed stone is recommended. Do not use sand or native soil as backfill. Mound the backfill slightly and allow for natural settling. Provide access to the basin cover for maintenance and service.



Do not exert heavy pressure or run heavy equipment on the backfill material as this could cause the tank to collapse.

NOTE: In high water table areas and as an extra pre-caution, add water to the tank up to the bottom of the inlet of the basin.

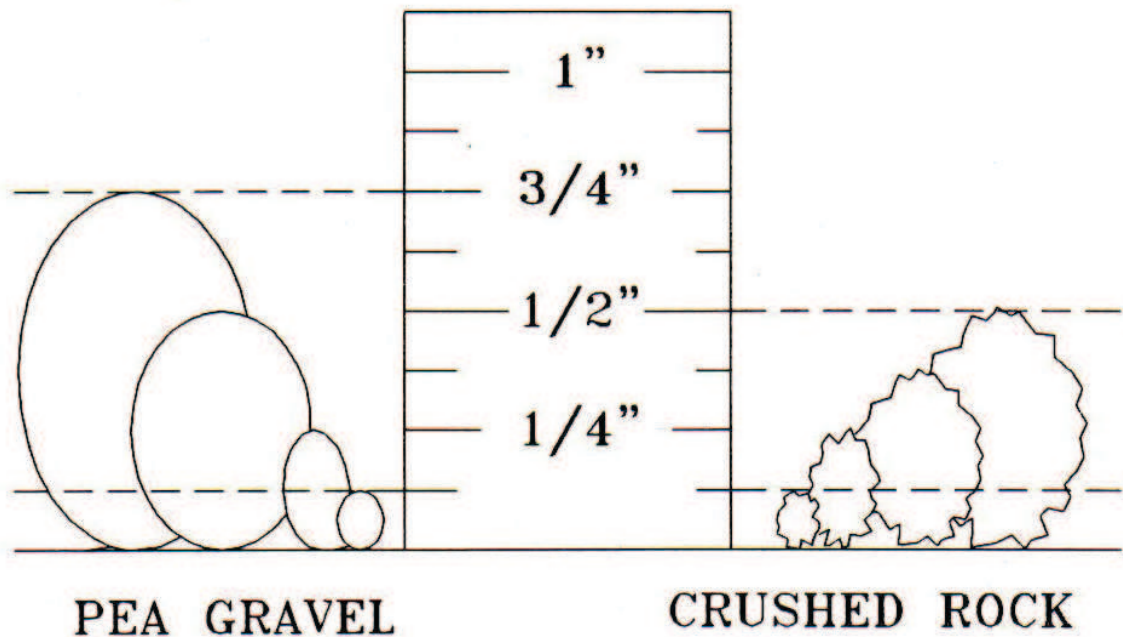

A. Inlet: Cut Inlet stub on basin $\frac{1}{2}$ " back from the end to allow for the connection of an inlet pipe using a flexible in-line pipe connector (4").

B. Discharge: Connect the discharge pipe to the check valve on the basin. **IMPORTANT:** Do not reduce the discharge pipe size below that which is provided on the pump. Sewage pumps should not be smaller than 2". In some applications, it may be necessary to increase the pipe size to reduce friction losses.

Install the remaining discharge line. A union should be installed to facilitate pump removal if necessary. A check valve is required to prevent the backflow of liquid after each pumping cycle. A gate or ball valve should follow the check valve to allow periodic cleaning of the check valve or removal of the pump. The remainder of the discharge line should be as short as possible with a minimum number of turns, to minimize friction head loss. Do not restrict the discharge below 2" in sewage applications. Larger pipe sizes may be required to eliminate friction head loss over long runs.

C. Vent: A threaded 2" connection is provided on top of the cover which must be piped to the existing building vent, or extended outside on its own standpipe. The vent size should be in accordance with applicable codes, but not less than the discharge size.

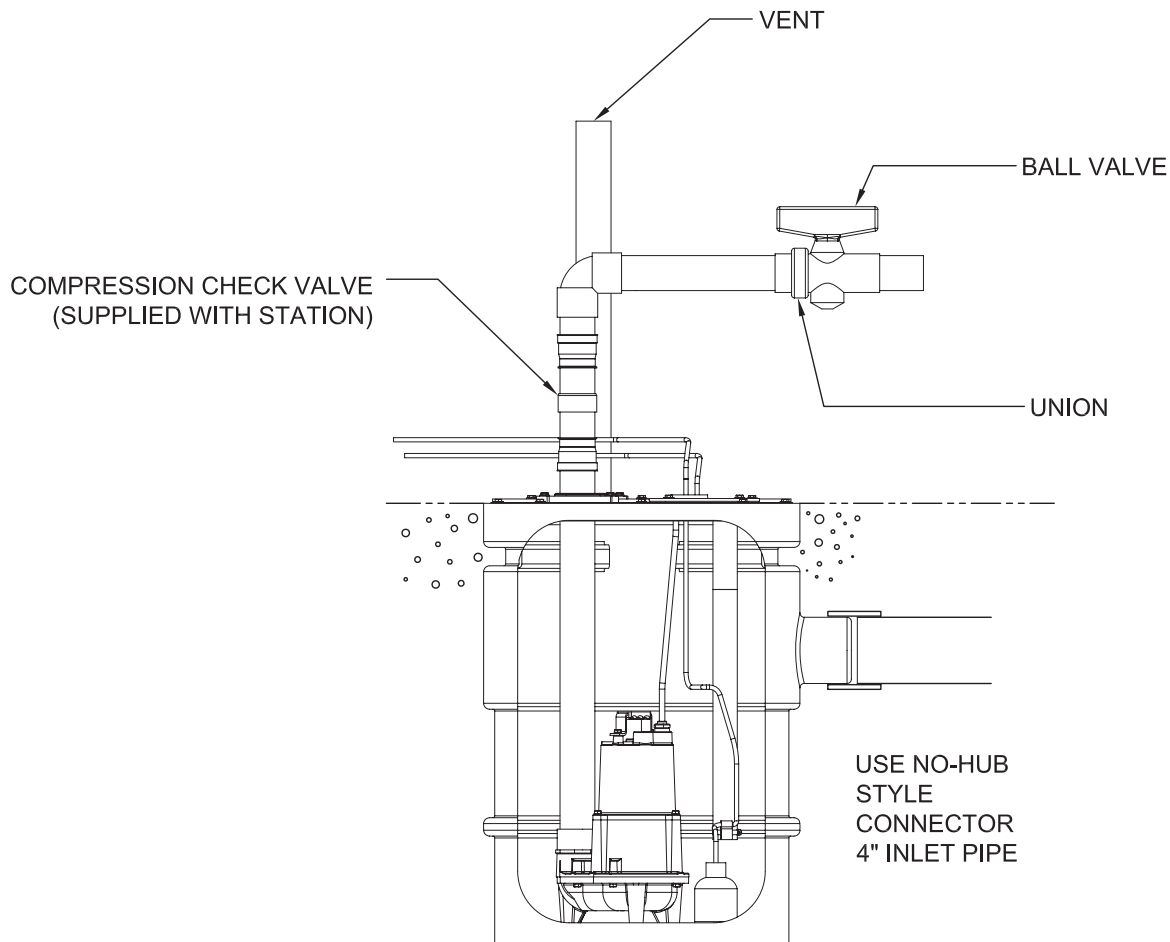
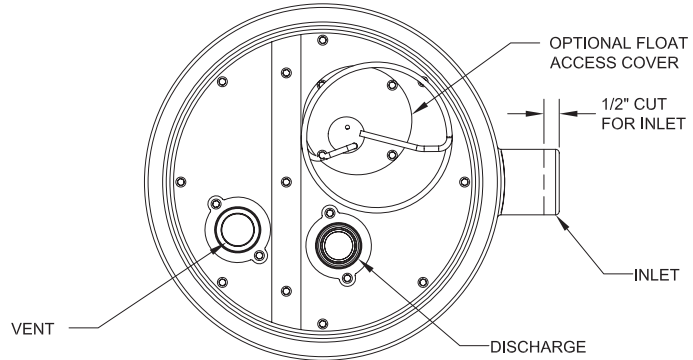

Access Cover

The basin packages feature Floatree technology. The Floatree float system uses a pvc pipe (tree) and cord clamping brackets to affix the pump float in the system. **All floats are pre-set at the factory at optimum levels and do not require adjustment in the pre-assembled versions.** **NOTE: Field adjusting floats may cause improper activation or turn-off of the pump.**

Floatree removal and float inspection: The Floatree system is located under the separate access cover to help ease inspection, service and replacement of a float. To inspect the float(s), simply unbolt the access cover and lift out the Floatree assembly from its holder. There is no need to disconnect plumbing or remove the pump. Basin packages feature a manual pump (with no switch attached directly to the pump). Operation of the pump is accomplished by the Floatree system.

Re-inserting the Floatree : After service or inspection of the floats, re-insert the Floatree into its holder. Cords from the pump, float switch and optional alarm need to be properly sealed as described below in the cord seal.

Cord Seal: It is important that cords from the pump motor and float switch are sealed in the specially designed rubber sealing channels in the cover. Proper sealing is required to keep sewer gas from leaking from the system. Place the cords securely in the rubber channels as shown in FIGURE B, being careful to remove excessive cord "slack" from inside the system. If the alarm cord is present, all three channels will be used. All rubber cover gaskets are permanently attached and do not require replacement.

IMPORTANT: Proper cord sealing

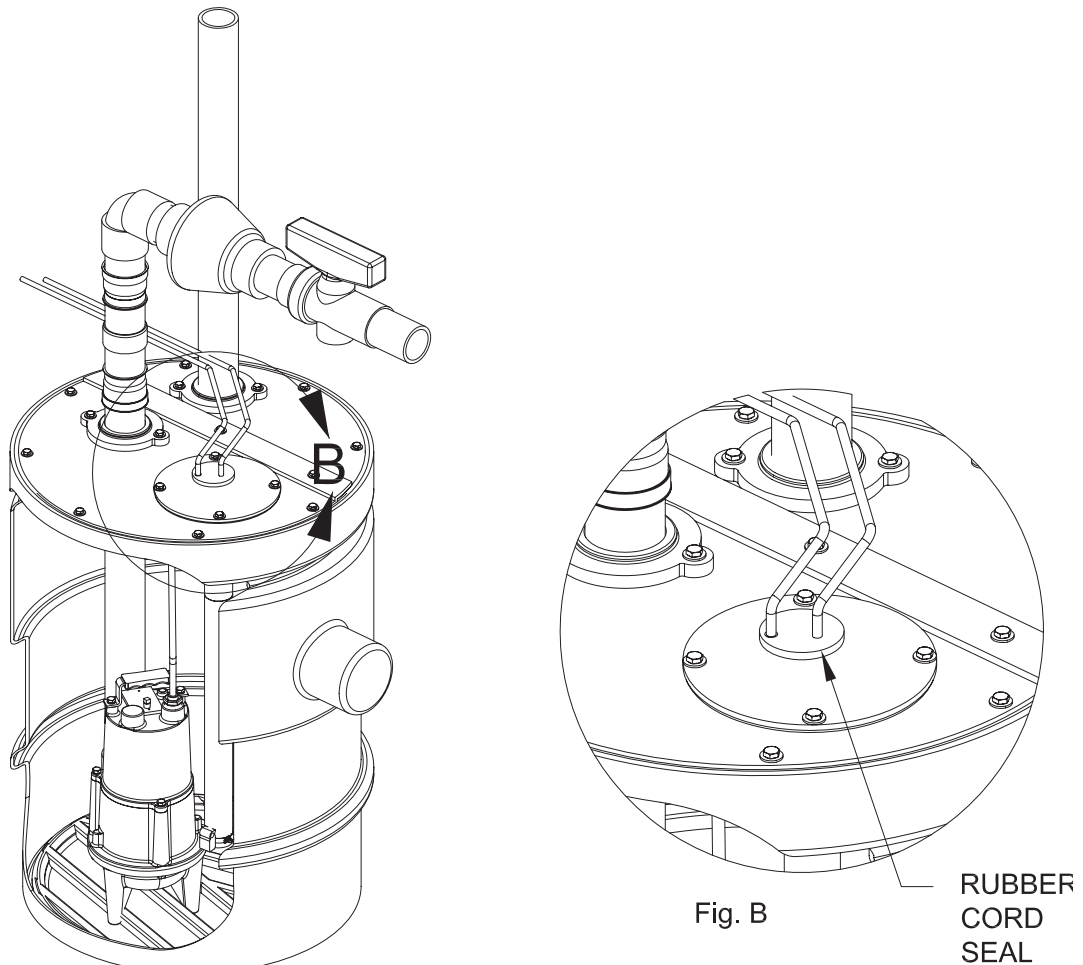

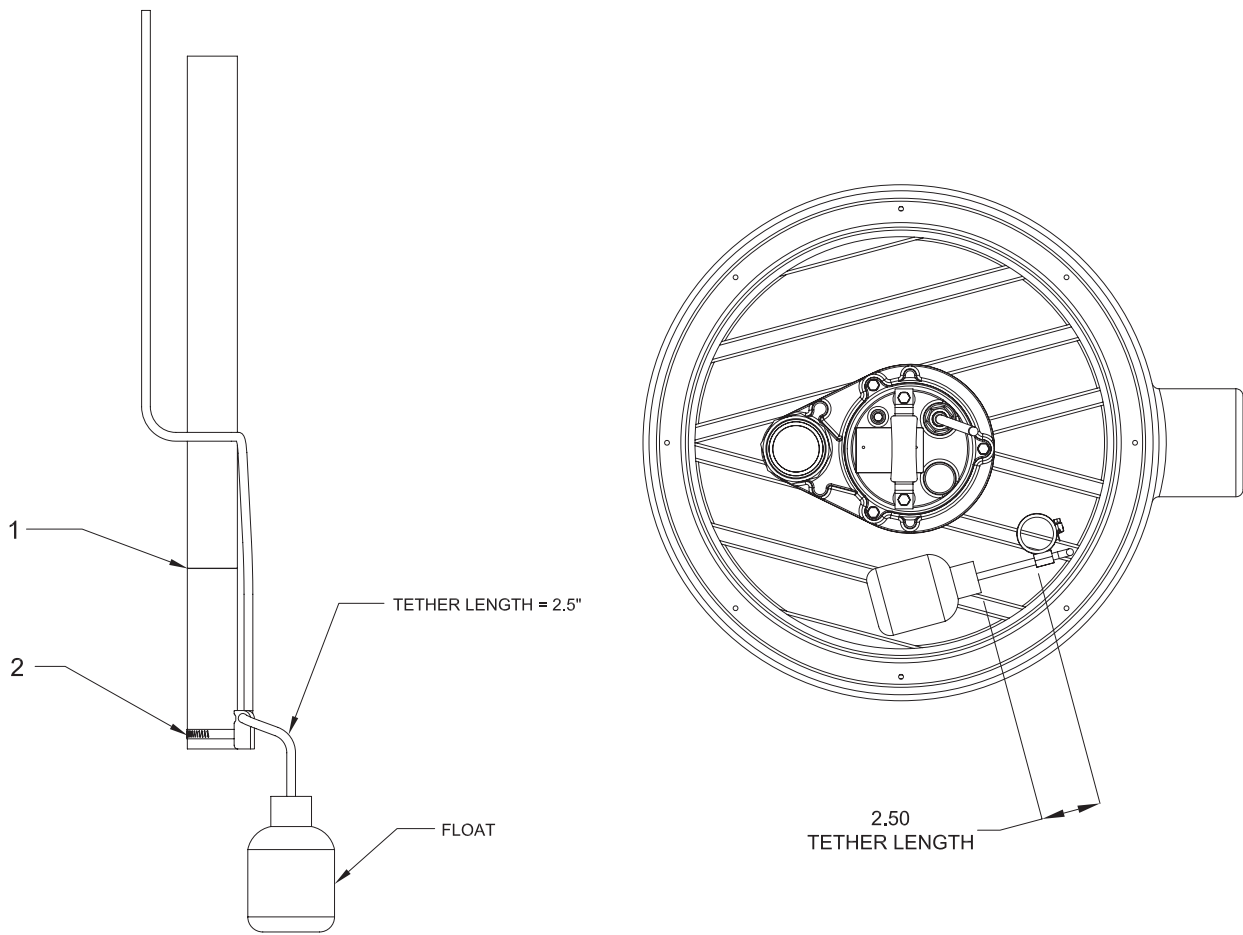

FLOATREE POSITION 1 IS DESIGNATED FOR THE SHORT 25" DIA. x 24" BASIN
 FLOATREE POSITION 2 IS DESIGNATED FOR THE TALL 20" DIA. x 30" BASIN

General Safety Information

Please read this before installing or operating pump. This information is provided for safety and to prevent equipment problems. To help recognize this information, observe the following symbols:

NOTE: Indicates special instructions which are important but not related to hazards.

IMPORTANT: Indicates factors concerned with assembly, installation, operation, or maintenance which could result in damage to the machine or equipment if ignored.



Warns about hazards that will or can cause minor personal injury or property damage if ignored.



Warns about hazards that can cause severe personal injury, death, or major property damage if ignored.



Warns about hazards that will cause serious personal injury, death, or major property damage if ignored.

1. Most accidents can be avoided by using COMMON SENSE.



Do not wear loose clothing that may become entangled in the impeller or other moving parts. Always wear appropriate safety gear, such as safety glasses, when working on the pump or piping.



Pumps build up heat and pressure during operation. Allow time for pumps to cool before handling or servicing.

2. Only qualified personnel should install, operate, and repair pump.



Keep clear of suction and discharge openings. Do not insert fingers in pump with power connected.



Do not pump hazardous materials (flammable, caustic, etc.) unless the pump is specifically designed and designated to handle them.

3. Make sure lifting handles are securely fastened each time before lifting.

4. Do not lift pump by the power cord.

5. Do not exceed manufacturer's recommendation for maximum performance, as this could cause the motor to overheat.

6. Secure the pump in its operating position so it can not tip over, fall, or slide.

7. Keep hands and feet away from impeller when power is connected.



Submersible pumps are not approved for use in swimming pools, recreational water installations, decorative fountains, or any installation where human contact with the pumped fluid is common.

8. Operation against a closed discharge valve will cause premature bearing and seal failure on any pump.



To reduce risk of electrical shock, pump must be properly grounded in accordance with the United States National Electric Code (NEC), or the Canadian Electrical Code (CEC) and all applicable state, and local codes and ordinances.



To reduce risk of electrical shock, always disconnect the pump from the power source before handling or servicing.

9. Any wiring of pumps should be performed by a qualified electrician.



Never operate a pump with a power cord that has frayed or brittle insulation.

10. Cable should be protected at all times to avoid punctures, cuts, bruises, and abrasions - inspect frequently.



Never handle connected power cords with wet hands. Never operate a 120 volt pump with a plug-in type power cord without a ground fault circuit interrupter.

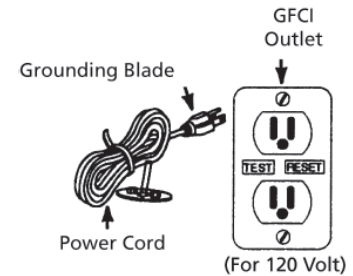

11. Do not remove cord and strain relief. Do not connect conduit to pump.



To reduce risk of electrical shock, all wiring and junction connections should be made per the United States National Electric Code (NEC), or the Canadian Electrical Code (CEC) and applicable state or province and local codes. Requirements may vary depending on usage and location. See wiring diagrams in manual.

Installation (Continued)



Do not use the power cable to lift pump.

OVERLOAD PROTECTION

Single Phase - The type of in-winding overload protector used is referred to as an inherent overheating protector and operates on the combined effect of temperature and current. This means that the overload protector will trip out and shut the pump off if the windings become too hot, or the load current passing through them becomes too high. It will then automatically reset and start the pump up after the motor cools to a safe temperature. In the event of an overload, the source of this condition should be determined and rectified immediately.



Do not cycle or run pump if an overload condition occurs!

If current through the temperature sensor exceeds the values listed, an intermediate control circuit relay must be used to reduce the current or the sensor will not work properly.

Wire Size

Consult a qualified electrician for proper wire size. See table on page 4 for electrical information.

Pre-operation

CHECK VOLTAGE AND PHASE

Before operating pump, check to make sure that the voltage and phase information stamped on the pump's identification plate matches the available power.

Temperature Sensor Electrical Ratings		
Volts	Continuous Amperes	Inrush Amperes
110 - 120	3.00	30.0

CHECK PUMP ROTATION (3 Phase Only)

Before putting pump into service for the first time, the motor rotation must be checked. Improper motor rotation can result in poor pump performance and can damage the motor and/or pump. To check the rotation, suspend the pump freely, momentarily apply power and observe the "kickback." "Kickback" should always be in a counter-clockwise direction as viewed from the top of the pump ("kickback" is always opposite to impeller rotation). "Rotation" and "kickback" direction is noted on the pump motor housing.

INCORRECT ROTATION

In the unlikely event that the rotation is incorrect for a single-phase pump, contact a Barnes Pumps Service Center.

IDENTIFICATION PLATE

Note the numbers on the pump's identification plate and record at the end of the manual for future reference.

PUMP-DOWN TEST

After the pump has been properly wired and lowered into the basin, sump, or lift station, it is advisable to check the system by filling with liquid and allowing the pump to operate through its pumping cycle. The time needed to empty the system, or pump-down time, should be recorded.



Electrical power to the pump motor must be disconnected and locked out to prevent any dangerous electrical hazards or personnel danger before any service work is done to the pump.



Operating pump builds up heat and pressure; allow time for pump to cool to room temperature before handling or servicing.



Always wear eye protection when working on pumps.

Troubleshooting Chart



Always disconnect the pump from the electrical power source before handling. If the system fails to operate properly, carefully read instructions and perform maintenance recommendations. If operating problems persist, the following chart may be of assistance in identifying and correcting them.

NOTE: Not all problems and corrections will apply to each pump model.

Symptom	Possible Cause (s)	Corrective Action
Pump will not run	<ol style="list-style-type: none"> Poor electrical connection, blown fuse, tripped breaker, or other interruption of power; improper power supply Motor or switch inoperative Float movement restricted Switch will not activate pump or is defective Defective motor Insufficient liquid level 	<ol style="list-style-type: none"> Check all electrical connections for security. Have electrician measure current in motor leads. If current is within $\pm 20\%$ of locked rotor Amps, impeller is probably locked. If current is 0, overload may be tripped. Remove power, allow pump to cool, then recheck current Go to manual operation of pump Reposition pump or clean basin as required to provide adequate clearance for float Disconnect level control. Set ohmmeter for a low range, such as 100 ohms full scale and connect to level control leads. Actuate level control manually and check to see that ohmmeter shows zero ohms for closed switch and full scale for open switch (Float Switch) Check winding insulation (Megger Test) and winding resistance. If check is outside of range, dry and recheck. If still defective, replace per service instructions Make sure liquid level is at least equal to suggested turn-on point
Pump will not turn off	<ol style="list-style-type: none"> Float movement restricted Switch will not activate pump or is defective Excessive inflow or pump not properly sized for application Pump may be airlocked 	<ol style="list-style-type: none"> Reposition pump or clean basin as required to provide adequate clearance for float Disconnect level control. Set ohmmeter for a low range, such as 100 ohms full scale and connect to level control leads. Actuate level control manually and check to see that ohmmeter shows zero ohms for closed switch and full scale for open switch (Float Switch) Recheck all sizing calculations to determine proper pump size Loosen union slightly to allow trapped air to escape. Verify that turn-off level of switch is set so that impeller cavity is always flooded. Clean vent hole
Pump hums but doesn't run	<ol style="list-style-type: none"> Incorrect voltage Impeller jammed or loose on shaft, worn, or damaged, impeller cavity or inlet plugged 	<ol style="list-style-type: none"> Check all electrical connections for security. Have electrician measure current in motor leads. If current is within $\pm 20\%$ of locked rotor Amps, impeller is probably locked. If current is 0, overload may be tripped. Remove power, allow pump to cool, then recheck current Check impeller for freedom of operation, security, and condition. Clean impeller cavity and inlet of any obstruction
Pump cycles too frequently or runs periodically when fixtures are not in use	<ol style="list-style-type: none"> Check valve stuck closed or installed backwards Fixtures are leaking Ground water entering basin 	<ol style="list-style-type: none"> Remove and examine check valve for proper installation and freedom of operation Repair fixtures as required to eliminate leakage Check for leaks around basin inlet and outlets

Troubleshooting Chart (Continued)

Symptom	Possible Cause (s)	Corrective Action
Pump delivers insufficient capacity	<ol style="list-style-type: none"> 1. Incorrect voltage 2. Excessive inflow or pump not properly sized for application 3. Discharge restricted 4. Check valve stuck closed or installed backwards 5. Shut-off valve closed 6. Impeller jammed or loose on shaft, worn or damaged, impeller cavity or inlet plugged 7. Pump may be airlocked 8. Pump running backwards 	<ol style="list-style-type: none"> 1. Check all electrical connections for security. Have electrician measure current in motor leads. If current is within $\pm 20\%$ of locked rotor Amps, impeller is probably locked. If current is 0, overload may be tripped. Remove power, allow pump to cool, then recheck current 2. Recheck all sizing calculations to determine proper pump size 3. Check discharge line for restrictions, including ice. If line passes through or into cold areas 4. Remove and examine check valve for proper installation and freedom of operation 5. Open valve 6. Check impeller for freedom of operation, security, and condition. Clean impeller cavity and inlet of any obstruction 7. Loosen union slightly to allow trapped air to escape. Verify that turn-off level of switch is set so that impeller cavity is always flooded. Clean vent hole 8. Check rotation. If power supply is three phase, reverse any two of three power supply leads to ensure proper impeller rotation
<p>Pump shuts off and turns on independent of switch (trips thermal overload protector)</p> <p> Pump may start unexpectedly. Disconnect power supply</p> <p>NOTE: Some pumps do not have thermal load protection on the motor. Check pump specifications to determine</p>	<ol style="list-style-type: none"> 1. Incorrect voltage 2. Excessive inflow or pump not properly sized for application 3. Impeller jammed, loose on shaft, worn or damaged; impeller cavity or inlet plugged 4. Excessive water temperature (internal protection only) 	<ol style="list-style-type: none"> 1. Check all electrical connections for security. Have electrician measure current in motor leads. If current is within $\pm 20\%$ of locked rotor Amps, impeller is probably locked. If current is 0, overload may be tripped. Remove power, allow pump to cool, then recheck current 2. Recheck all sizing calculations to determine proper pump size 3. Check impeller for freedom of operation, security, and condition. Clean impeller cavity and inlet of any obstruction 4. Check pump temperature limits & fluid temperature
Pump operates noisily or vibrates excessively	<ol style="list-style-type: none"> 1. Worn bearings, motor shaft bent 2. Debris in impeller cavity or broken impeller 3. Pump running backwards 4. Piping attachments to building structure too rigid or too loose 	<ol style="list-style-type: none"> 1. Check winding insulation (Megger Test) and winding resistance. If check is outside of range, dry and recheck. If still defective, replace per service instructions 2. Check impeller for freedom of operation, security, and condition. Clean impeller cavity and inlet of any obstruction 3. Check rotation. If power supply is three phase, reverse any two of three power supply leads to ensure proper impeller rotation 4. Replace portion of discharge pipe with flexible connector

Ref. No.	Description	Part. No.	Qty.
1	Basin / Split Cover	See BOM	1
3	Post, Float	126893	1
4	Check Valve	126895	1
5	Discharge, 2"	104601	1
6	Float, Mech.	See BOM	1
7	Manual	126898	1
8	Pump	See BOM	1

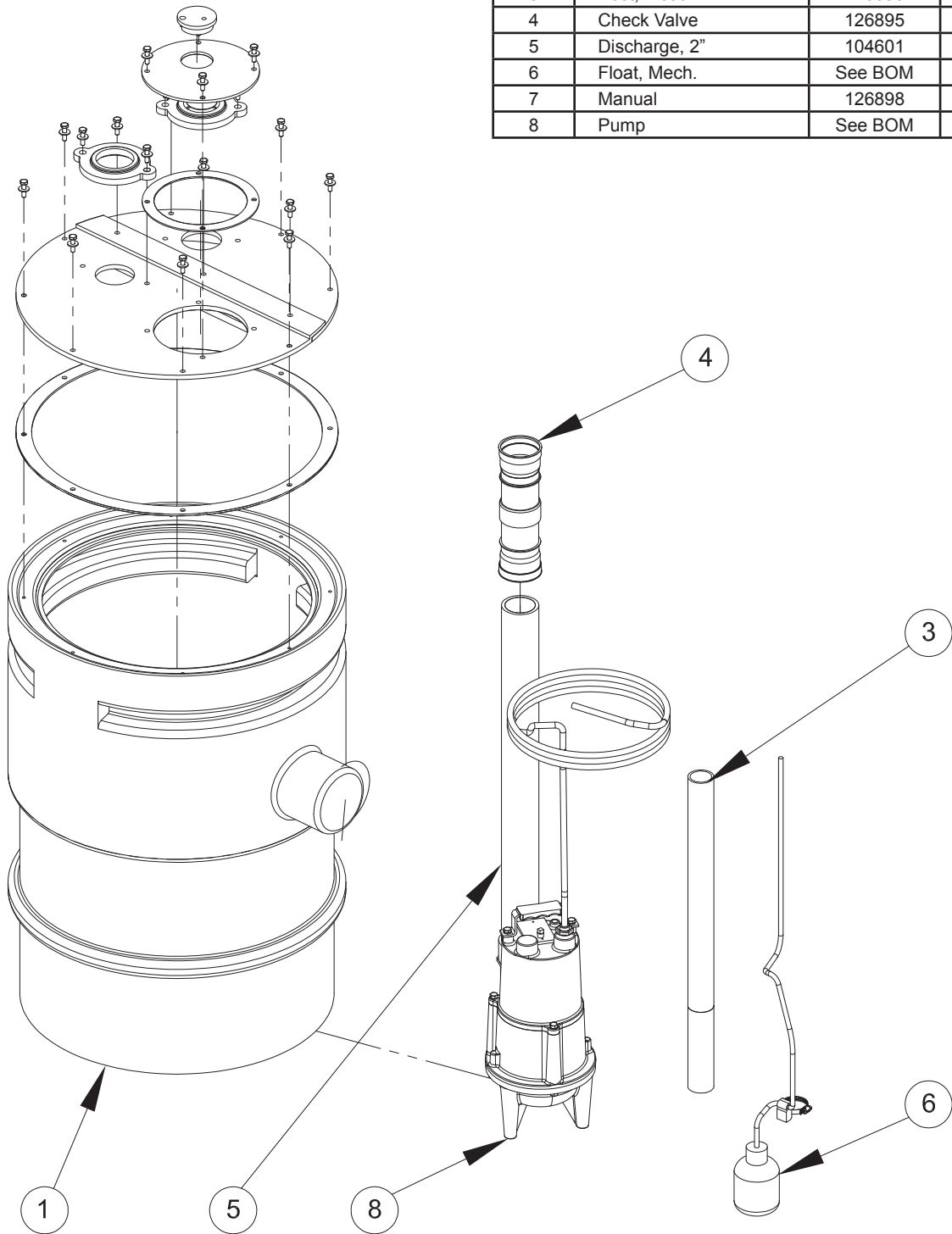

BARNES®



burks®

WEINMAN®

DEMING®

PROSSER®

Limited 24 Month Warranty

Crane Pumps & Systems warrants that products of our manufacture will be free of defects in material and workmanship under normal use and service for twenty-four (24) months after manufacture date, when installed and maintained in accordance with our instructions. This warranty gives you specific legal rights, and there may also be other rights which vary from state to state. In the event the product is covered by the Federal Consumer Product Warranties Law (1) the duration of any implied warranties associated with the product by virtue of said law is limited to the same duration as stated herein, (2) this warranty is a LIMITED WARRANTY, and (3) no claims of any nature whatsoever shall be made against us, until the ultimate consumer, his successor, or assigns, notifies us in writing of the defect, and delivers the product and/or defective part(s) freight prepaid to our factory or nearest authorized service station. Some states do not allow limitations on how long an implied warranty lasts, so the above limitation may not apply. **THE SOLE AND EXCLUSIVE REMEDY FOR BREACH OF ANY AND ALL WARRANTIES WITH RESPECT TO ANY PRODUCT SHALL BE TO REPLACE OR REPAIR AT OUR ELECTION, F.O.B. POINT OF MANUFACTURE OR AUTHORIZED REPAIR STATION, SUCH PRODUCTS AND/OR PARTS AS PROVEN DEFECTIVE. THERE SHALL BE NO FURTHER LIABILITY, WHETHER BASED ON WARRANTY, NEGLIGENCE OR OTHERWISE.** Unless expressly stated otherwise, guarantees in the nature of performance specifications furnished in addition to the foregoing material and workmanship warranties on a product manufactured by us, if any, are subject to laboratory tests corrected for field performance. Any additional guarantees, in the nature of performance specifications must be in writing and such writing must be signed by our authorized representative. Due to inaccuracies in field testing if a conflict arises between the results of field testing conducted by or for user, and laboratory tests corrected for field performance, the latter shall control. **RECOMMENDATIONS FOR SPECIAL APPLICATIONS OR THOSE RESULTING FROM SYSTEMS ANALYSES AND EVALUATIONS WE CONDUCT WILL BE BASED ON OUR BEST AVAILABLE EXPERIENCE AND PUBLISHED INDUSTRY INFORMATION. SUCH RECOMMENDATIONS DO NOT CONSTITUTE A WARRANTY OF SATISFACTORY PERFORMANCE AND NO SUCH WARRANTY IS GIVEN.**

This warranty shall not apply when damage is caused by (a) improper installation, (b) improper voltage (c) lightning (d) excessive sand or other abrasive material (e) scale or corrosion build-up due to excessive chemical content. Any modification of the original equipment will also void the warranty. We will not be responsible for loss, damage or labor cost due to interruption of service caused by defective parts. Neither will we accept charges incurred by others without our prior written approval.

This warranty is void if our inspection reveals the product was used in a manner inconsistent with normal industry practice and/or our specific recommendations. The purchaser is responsible for communication of all necessary information regarding the application and use of the product. **UNDER NO CIRCUMSTANCES WILL WE BE RESPONSIBLE FOR ANY OTHER DIRECT OR CONSEQUENTIAL DAMAGES, INCLUDING BUT NOT LIMITED TO TRAVEL EXPENSES, RENTED EQUIPMENT, OUTSIDE CONTRACTOR FEES, UNAUTHORIZED REPAIR SHOP EXPENSES, LOST PROFITS, LOST INCOME, LABOR CHARGES, DELAYS IN PRODUCTION, IDLE PRODUCTION, WHICH DAMAGES ARE CAUSED BY ANY DEFECTS IN MATERIAL AND/OR WORKMANSHIP AND/OR DAMAGE OR DELAYS IN SHIPMENT. THIS WARRANTY IS EXPRESSLY IN LIEU OF ANY OTHER EXPRESS OR IMPLIED WARRANTY, INCLUDING ANY WARRANTY OF MERCHANTABILITY OR FITNESS FOR A PARTICULAR PURPOSE.**

No rights extended under this warranty shall be assigned to any other person, whether by operation of law or otherwise, without our prior written approval.



A Crane Co. Company

PUMPS & SYSTEMS

420 Third Street
Piqua, Ohio 45356
(937) 778-8947
Fax (937) 773-7157
www.cranepumps.com

83 West Drive
Brampton, Ont. Canada L6T 2J6
(905) 457-6223
Fax (905) 457-2650

**IMPORTANT!
WARRANTY REGISTRATION**

Your product is covered by the enclosed Warranty.
To complete the Warranty Registration Form go to:

<http://www.cranepumps.com/ProductRegistration/>

If you have a claim under the provision of the warranty, contact your local
Crane Pumps & Systems, Inc. Distributor.

RETURNED GOODS

**RETURN OF MERCHANDISE REQUIRES A "RETURNED GOODS AUTHORIZATION".
CONTACT YOUR LOCAL CRANE PUMPS & SYSTEMS, INC. DISTRIBUTOR.**



**Products Returned Must Be Cleaned, Sanitized,
Or Decontaminated As Necessary Prior To Shipment,
To Insure That Employees Will Not Be Exposed To Health
Hazards In Handling Said Material. All Applicable Laws
And Regulations Shall Apply.**

