

BARNES[®]

INSTALLATION and OPERATION MANUAL Centrifugal Pumps

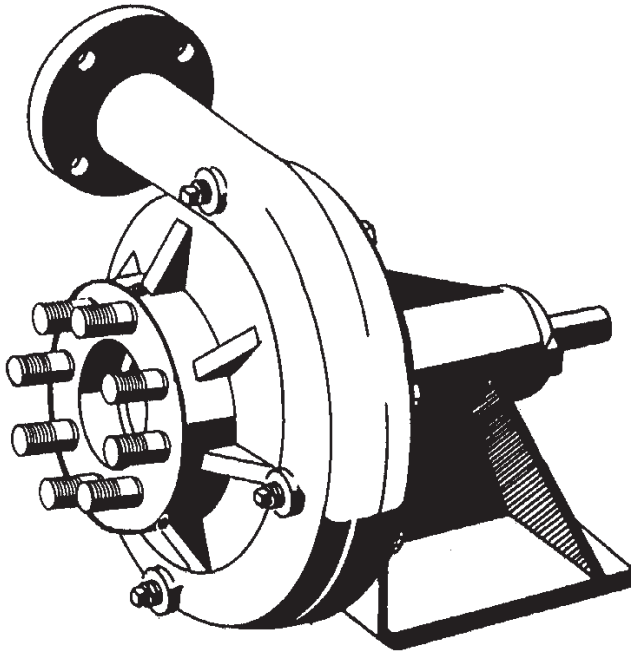

Model: 4030HCU

IMPORTANT!

*Read all instructions in this manual before operating pump.
As a result of Crane Pumps & Systems, Inc., constant product improvement program,
product changes may occur. As such Crane Pumps & Systems reserves the right to
change product without prior written notification.*

CRANE[®]

A Crane Co. Company

PUMPS & SYSTEMS

420 Third Street
Piqua, Ohio 45356
Phone: (937) 778-8947
Fax: (937) 773-7157
www.cranepumps.com

83 West Drive, Brampton
Ontario, Canada L6T 2J6
Phone: (905) 457-6223
Fax: (905) 457-2650

Form No. 052320-Rev. K

TABLE OF CONTENTS

SAFETY FIRST	3
A. PUMP SPECIFICATIONS	4
B. GENERAL INFORMATION	5
C. INSTALLATION	5
D. OPERATION	5
E. PUMP SERVICE and REPAIR	5 - 6
F. REPLACEMENT PARTS.....	6
TRUBLE SHOOTING	7
CROSS-SECTION	8
EXPLODED VIEW	9
PARTS LIST	10
RETURNED GOODS POLICY.....	11
WARRANT	12
START-UP REPORT	13 - 15
WARRANTY REGISTRATION	

SAFETY FIRST!

Please Read This Before Installing Or Operating Pump.
This information is provided for **SAFETY and to PREVENT EQUIPMENT PROBLEMS**. To help recognize this information, observe the following symbols:



IMPORTANT! Warns about hazards that can result in personal injury or Indicates factors concerned with assembly, installation, operation, or maintenance which could result in damage to the machine or equipment if ignored.

CAUTION ! Warns about hazards that can or will cause minor personal injury or property damage if ignored. Used with symbols below.

WARNING ! Warns about hazards that can or will cause serious personal injury, death, or major property damage if ignored. Used with symbols below.



Hazardous fluids can cause fire or explosions, burnes or death could result.



Extremely hot - Severe burnes can occur on contact.



Biohazard can cause serious personal injury.



Hazardous fluids can Hazardous pressure, eruptions or explosions could cause personal injury or property damage.



Rotating machinery Amputation or severe laceration can result.



Hazardous voltage can shock, burn or cause death.



Toxic Fumes - Breathing can cause nausea, fainting or death



Eye protection required

Only qualified personnel should install, operate and repair pump. Any wiring of pumps should be performed by a qualified electrician.



WARNING! Operation against a closed discharge valve will cause premature bearing and seal failure on any pump, and on end suction and self priming pump the heat build

may cause the generation of steam with resulting dangerous pressures. It is recommended that a high case temperature switch or pressure relief valve be installed on the pump body.



CAUTION! Pumps build up heat and pressure during operation-allow time for pumps to cool before handling or servicing.



WARNING! - DO NOT pump hazardous materials (flammable, caustic, etc.) unless the pump is specifically designed and designated to handle them.



CAUTION! - Do not block or restrict discharge hose, as discharge hose may whip under pressure.



WARNING! - DO NOT wear loose clothing that may become entangled in the impeller or other moving parts. Always wear appropriate safety gear, such as safety glasses, when working on the pump or piping.



WARNING! - Keep clear of suction and discharge openings. **DO NOT** insert fingers in pump with power connected.



Always wear eye protection when working on pumps.



Make sure lifting handles are securely fastened each time before lifting. **DO NOT** operate pump without safety devices in place. Always replace safety devices that have been removed during service or repair. Secure the pump in its operating position so it can not tip over, fall or slide.

DO NOT exceed manufacturers recommendation for maximum performance, as this could cause the motor to overheat.

When towing pump behind a vehicle, make sure hitch is properly attached, always attach safety chains.



WARNING! If Engine driven, never operate in an enclosed building or area where exhaust gases can accumulate. Never operate near a building where exhaust gases can seep inside. Never operate in a pit or sump without making provisions for adequate ventilation.



WARNING! Do not breathe exhaust fumes when working in the area of the engine. (Exhaust gases are odorless and deadly poison.)



WARNING! Allow exhaust system to cool before touching.



Never add fuel to the tank while the engine is running. Stop engine and allow to cool. Do not smoke while refueling the engine. Do not refuel near open flame



Carefully read instruction manuals supplied by engine manufacture before attempting to assemble, operate or service the engine or any part. The "WARNING" statements indicate potentially hazardous conditions for operator or equipment.



WARNING! Products Returned Must Be Cleaned, Sanitized, Or Decontaminated As Necessary Prior To Shipment, To Insure That Employees Will Not Be Exposed To Health Hazards In Handling Said Material. All Applicable Laws And Regulations Shall Apply.



Bronze/brass and bronze/brass fitted pumps may contain lead levels higher than considered safe for potable water systems. Lead is know to cause cancer and birth defects or other reproductive harm. Various government agencies have determined that leaded copper alloys should not be used in potable water applications. For non-leaded copper alloy materials of construction, please contact factory.



IMPORTANT! - Crane Pumps & Systems, Inc. is not responsible for losses, injury, or death resulting from a failure to observe these safety precautions, misuse or abuse of pumps or equipment.

SECTION: A - PUMP SPECIFICATIONS:

SUCTION/DISCHARGE. 4" (102mm) Suction, 3" (76mm) Discharge, 125 lb Flange.
 Discharge can be placed in 8 different locations depending on piping requirements

LIQUID TEMPERATURE 180°F (82°C) Continuous

BODY Cast Iron ASTM Class 30, with Air vent, Vacuum pressure and drain plugs.

PEDESTAL..... Cast Iron ASTM A Class 30

IMPELLER
Design..... Enclosed type
Material Cast Iron ASTM Class 30
 Dynamically Balanced, ISO G6.3

WEAR RING..... Bronze

SHAFT..... Steel

SHAFT SLEEVE Bronze

HARDWARE 300 Series Stainless Steel

PAINT Air dry enamel

SEAL: *Design*..... Single Mechanical
Lubrication.... Self-Lubrication
Material Rotating Faces - Carbon
 Stationary Faces - Ni-Resist
 Elastomer - Buna-N
 Hardware - 300 series stainless steel

BEARING-PUMP END:
Design..... Single Row, Ball
Lubrication.... Grease, Factory Lubrication
Load Radial & Thrust

BEARING-DRIVE END:
Design..... Single Row, Ball
Lubrication.... Grease, Factory Lubrication
Load Radial & Thrust

OPTIONAL EQUIPMENT: Discharge Check Valve, Hand Primer, Base & OSHA Coupling Guard, Flex Coupling, Strainer, Bronze Impeller, Companion Flange, Flange Gasket.

inches
(mm)

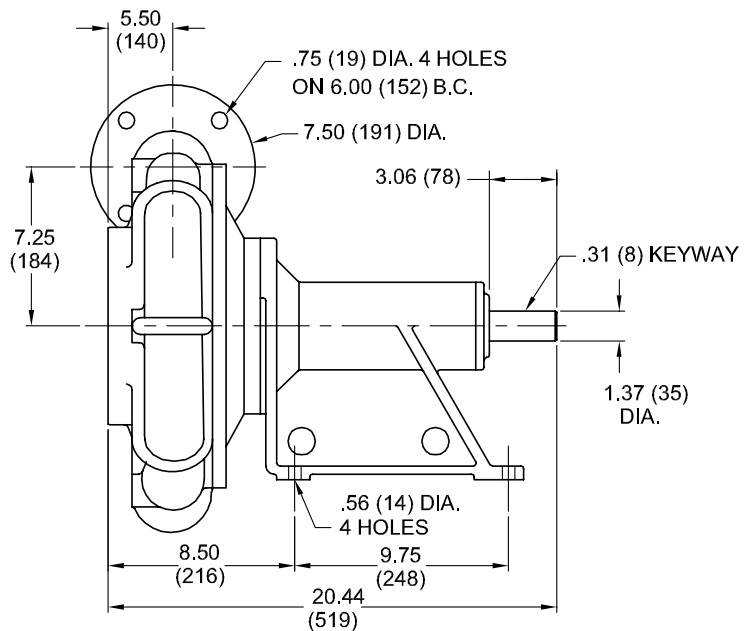
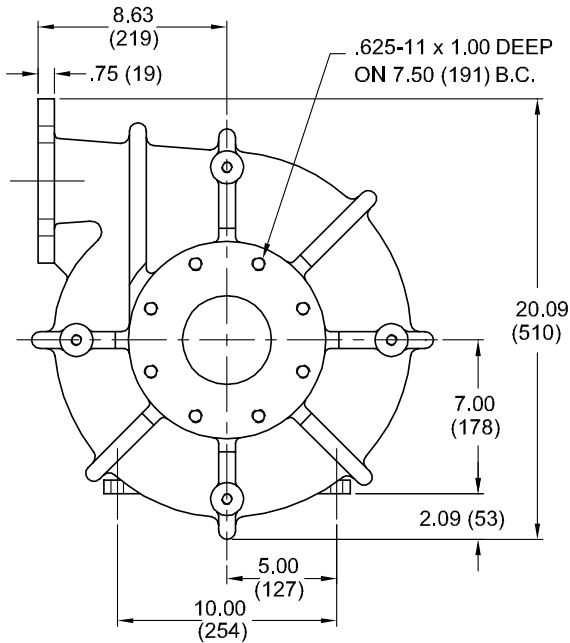

IMPORTANT!

- 1.) **DO NOT USE FOR PUMPING FLUIDS WITH A FLASH POINT OF LESS THAN 100°F.**
- 2.) **MAKE CERTAIN THAT PUMP AND/OR MOTOR ASSEMBLY AND CONTROLS HAVE THE APPROPRIATE RATINGS FOR THE GIVEN APPLICATION AREA CLASSIFICATION (ie DIVISION I, AGENCY LISTING ETC.)**

SECTION B: GENERAL INFORMATION

B-1) To the Purchaser:

Congratulations! You are the owner of one of the finest pumps on the market today. Barnes® Pumps are products engineered and manufactured of high quality components. Over one hundred years of pump building experience along with a continuing quality assurance program combine to produce a pump which will stand up to the toughest applications.

This manual will provide helpful information concerning installation, maintenance, and proper service guidelines.

B-2) Receiving:

Upon receiving the pump, it should be inspected for damage or shortages. If damage has occurred, file a claim immediately with the company that delivered the pump. If the manual is removed from the packaging, do not lose or misplace.

B-3) Storage:

Short Term- Barnes pumps are manufactured for efficient performance following short inoperative periods in storage. For best results, pumps can be retained in storage, as factory assembled, in a dry atmosphere with constant temperatures for up to six (6) months.

Long Term- Any length of time exceeding six (6) months, but not more than twenty four (24) months. The units should be stored in a temperature controlled area, a roofed over walled enclosure that provides protection from the elements (rain, snow, wind-blown dust, etc.), and whose temperature can be maintained between +40 deg. F and +120 deg. F. If extended high humidity is expected to be a problem, all exposed parts should be inspected before storage and all surfaces that have the paint scratched, damaged, or worn should be recoated with a water base, air dry enamel paint. All surfaces should then be sprayed with a rust-inhibiting oil.

Pump should be stored in its original shipping container. On initial start up, rotate impeller by hand to assure seal and impeller rotate freely.

B-4) Service Centers:

For the location of the nearest Barnes Service Center, check your Barnes representative or Crane Pumps & Systems, Inc. Service Department in Piqua, Ohio, telephone (937) 778-8947 or Crane Pumps & Systems Canada, Inc., in Bramton, Ontario (905) 457-6223.

SECTION C: INSTALLATION:

C-1) Location:

The pump should be located as near as possible to the liquid to be pumped and in no case should the pump be more than 25 feet above the surface of the liquid supply. The pump should always be as level as possible.

C-2) Suction System:

Connect suction pipe or hose to suction inlet. If hose is used, it should be of the reinforced type to prevent collapsing under suction. Make sure all suction system connections are tight and free of air leaks, as even a very slight leak will greatly reduce priming ability and pumping efficiency.



CAUTION! - This pump should not be operated without a strainer on the end of the suction line to prevent sticks, stones, rags and other foreign matter from being drawn into the impeller. The strainer should be cleaned regularly to insure full flow.

C-3) Discharge System:

Connect discharge hose or pipe to discharge opening in pump.

C-4) Lubrication:

The pump requires no lubrication. It is equipped with a mechanical shaft seal which is lubricated by the liquid being pumped. The pump is equipped with ball bearings which have been pack with lubricant at the factory. Under average condition, the grease used is normally good for 5,000 hours or one year, whichever comes first. The bearings should then be repacked per Section E-3.



CAUTION! - DO NOT operate pump without liquid in the pump body as operating pump dry will result in damage to the seal.

SECTION D: OPERATION:

D-1) Priming:

Prime pump by filling volute and suction line completely with liquid. Allow air to escape by loosening plug (5), in top of volute (1). Make sure all the air is out of the suction line and volute, or pump will not prime properly. Pump requires foot valve for priming or flooded suction. In freezing weather, the pump should be primed with warm water if possible. If the pump has been pumping liquid containing a considerable amount of foreign matter, it is advisable to flush the foreign matter out of the body before refilling with liquid.

SECTION E: PUMP SERVICE AND REPAIR:

E-1) Impeller Service:

To service or clean impeller, disconnect suction and discharge piping. Remove hex nuts (4) and lockwashers (3), and pull volute (1) from seal plate (15). The impeller (8), screw (9) washer (10) wear ring (6) and o-ring (13) are now exposed for examination or replacement.

To remove impeller (8), hold pulley or coupling so shaft will not move and remove impeller screw (9), washer (10), impeller (8) and wear ring (6). Impeller screw (9) threads are right hand and to loosen, turn counter-clockwise. Examine impeller and wear rings (9) and (11), replace if required.

E-2) Shaft Seal Service:

To expose the seal for examination or replacement, remove volute and impeller as outlined in Section E-1. Remove rotating member (12A) from shaft sleeve (14). All of the components of the shaft seal are now exposed for examination or repair. If any part of the shaft seal shows wear or damage, replace entire seal assembly.

When stationary member (12B) needs replaced, remove cap screws (18), lockwashers (19), and pull seal plate (15) from pedestal (17). Press used stationary member (12B) from seal plate.



CAUTION! - Handle seal parts with extreme care. DO NOT scratch or mar lapped faces.

Replace seal plate (15) onto pedestal (17). Lightly oil and replace shaft sleeve (14) and cup of stationary member (12B), press stationary member (12B) over shaft sleeve and into seal plate (15). Lightly oil shaft sleeve and inner surface of bellows of rotating member (12A). With lapped surface facing coupling, slide rotating member (12A) onto shaft sleeve until lapped faces of (12A) and (12B) are together. Reassemble remainder of pump.

E-3) Shaft and Bearing Service:

Remove volute, impeller and shaft seal as outlined in Sections E-1 and E-2. Remove cap screw (21), and lockwashers (22), and pull bearing cap (20) from pedestal (17). Tap on drive end of shaft (28) with a block of wood and a hammer to drive the shaft (28) and bearings (26) and (30) from pedestal (17). Examine all parts and replace those showing wear and/or damage.

Upon reassembly, fill the bearing housing and shaft between the bearings approximately 1/3 full with grease, such as SOHIO FACTRAN EP-3, or equal. Reassemble remainder of pump.

SECTION: F REPLACEMENT PARTS

F-1 ORDERING REPLACEMENT PARTS:

When ordering replacement parts, ALWAYS furnish the following information:

1. Pump serial number and date code. (F-4)
2. Pump model number. (F-3)
3. Pump part number. (F-2)
4. Part description.
5. Item part number.
6. Quantity required.
7. Shipping instructions.
8. Billing instructions.

F-2 PART NUMBER:

The part number consists of a six (6) digit number, which appears in the catalog. A one or two letter suffix may follow this number to designate the design configuration. This number is used for ordering and obtaining information.

F-3 MODEL NUMBER:

This designation consists of numbers and letters which represent the discharge size, series horsepower, motor phase and voltage, speed and pump design. This number is used for ordering and obtaining information.

F-4 SERIAL NUMBER:

The serial number block will consist of a six digit number, which is specific to each pump and may be preceded by a alpha character, which indicates the plant location. This number will also be suffixed with a four digit number, which indicates the date the unit was built (Date Code).

EXAMPLE: A012345 0490.

Reference the six digit portion (Serial Number) of this number when referring to the product.

TROUBLE SHOOTING

CAUTION ! Always disconnect the pump from the electrical power source before handling.
If the system fails to operate properly, carefully read instructions and perform maintenance recommendations.

SYMPTOM	POSSIBLE CAUSE(S)	
Little or no discharge and unit will not prime	<ol style="list-style-type: none"> 1. Casing not filled with water 2. Total head too high 3. Suction head higher than pump designed for 4. Impeller partially or completely plugged 5. Hole or leak in suction line 6. Foot-valve too small 7. Impeller damaged 8. Foot-valve or suction line not submerged deep enough in water; pulling air 9. Insufficient inlet pressure or suction head 10. Suction piping too small 11. Casing gasket leaking 12. Suction or discharge line valves closed 13. Piping is fouled or damaged 14. Clogged strainer or foot-valve 	<ol style="list-style-type: none"> 1. Fill pump casing. Using a foot-valve will extend pump life and facilitate immediate priming 2. Shorten suction head 3. Lower suction head, install foot-valve and prime. 4. Disassemble pump and clean out impeller 5. Repair or replace suction line 6. Match foot-valve to piping or install one size larger foot-valve 7. Disassemble pump and replace impeller 8. Submerge lower in water 9. Increase inlet pressure by adding more water to tank or increasing back pressure by turning gate valve on discharge line partially closed position 10. Increase pipe size to pump inlet size or larger 11. Replace 12. Open 13. Clean or replace 14. Clean or replace
Loss of suction after satisfactory operation	<ol style="list-style-type: none"> 1. Air leak in suction line 2. When unit was last turned off, water siphoned out of pump casing 3. Suction head higher than pump designed for 4. Insufficient inlet pressure or suction head 5. Clogged foot-valve, strainer, or pump 6. Defective wearplate(s) 	<ol style="list-style-type: none"> 1. Repair or replace suction line 2. Refill (reprime) pump casing before restarting 3. Lower suction head, install foot-valve and primer 4. Increase inlet pressure by adding more water to tank or increasing back pressure by turning gate valve on discharge line to partially closed position. 5. Unclog, clear or replace as necessary. 6. Replace.
Pump overloads driver	<ol style="list-style-type: none"> 1. Total head lower than pump rating, unit delivering too much water 2. Specific gravity and viscosity of liquid being pumped different than the pump rating 	<ol style="list-style-type: none"> 1. Increase back pressure on pump by turning gate valve on discharge line to partially closed position that will not overload motor. 2. Consult factory.
Pump vibrates and/or makes excessive noise	<ol style="list-style-type: none"> 1. Mounting plate or foundation not rigid enough 2. Foreign material in pump causing unbalance 3. Impeller bent 4. Cavitation present 5. Piping not supported to relieve any strain on pump assembly 	<ol style="list-style-type: none"> 1. Reinforce. 2. Disassemble pump and remove. 3. Replace impeller. 4. Check suction line for proper size and check valve in suction line if completely open, remove any sharp bends before pump and shorten suction line. 5. Make necessary adjustments.
Pump runs but no fluid	<ol style="list-style-type: none"> 1. Faulty suction piping (air leak) 2. Pump located too far from fluid source 3. Gate valve closed 4. Clogged strainer 5. Fouled foot-valve 6. Discharge height too great 7. Fouled impeller 8. Faulty mechanical seal 	<ol style="list-style-type: none"> 1. Replace 2. Replace 3. Open 4. Clean or replace 5. Clean or replace 6. Lower the height 7. Clean or replace. 8. Replace
Pump leaks at shaft	<ol style="list-style-type: none"> 1. Worn mechanical seal 2. Replacement seal not installed properly 	<ol style="list-style-type: none"> 1. Replace 2. Follow Maintenance instructions carefully

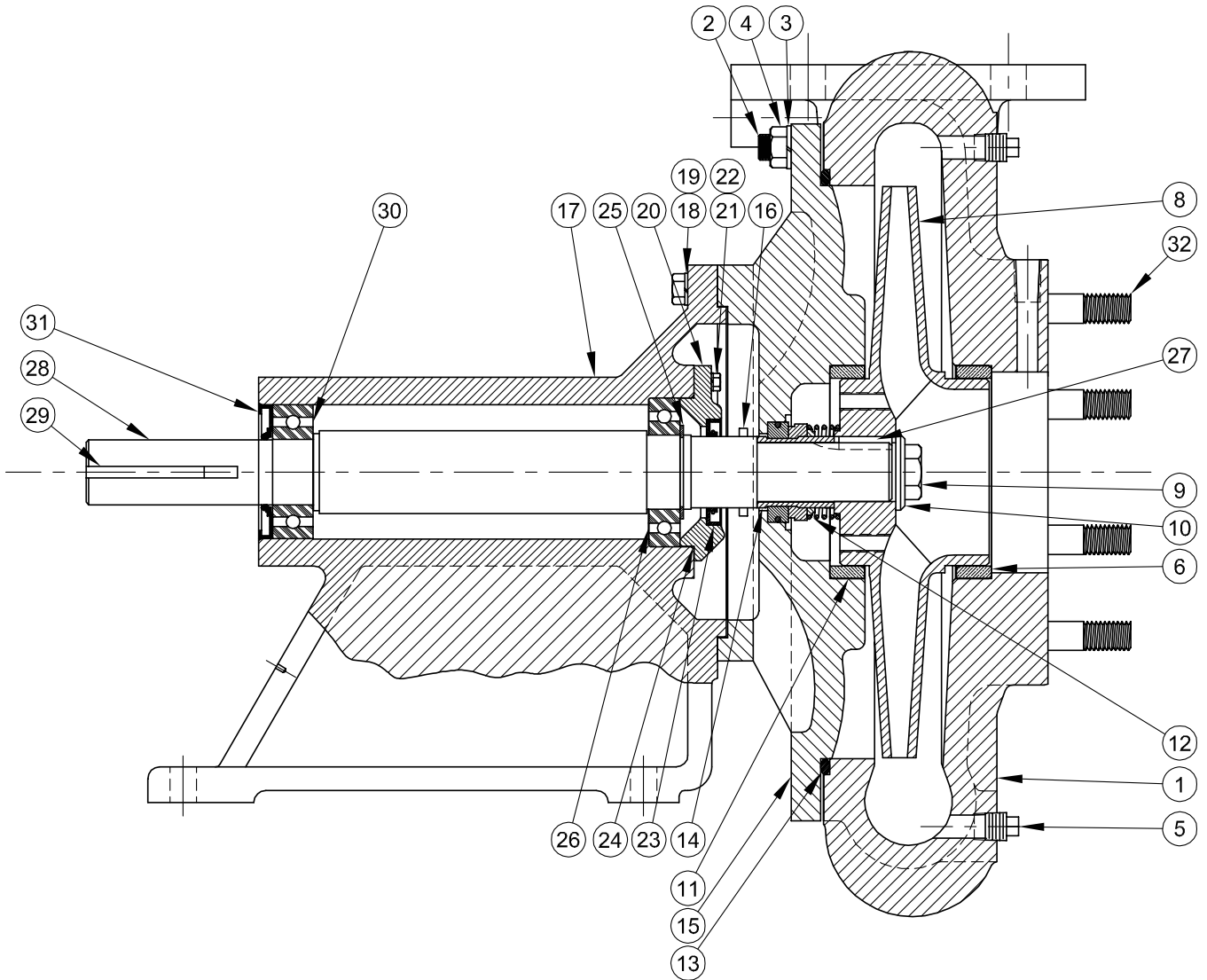

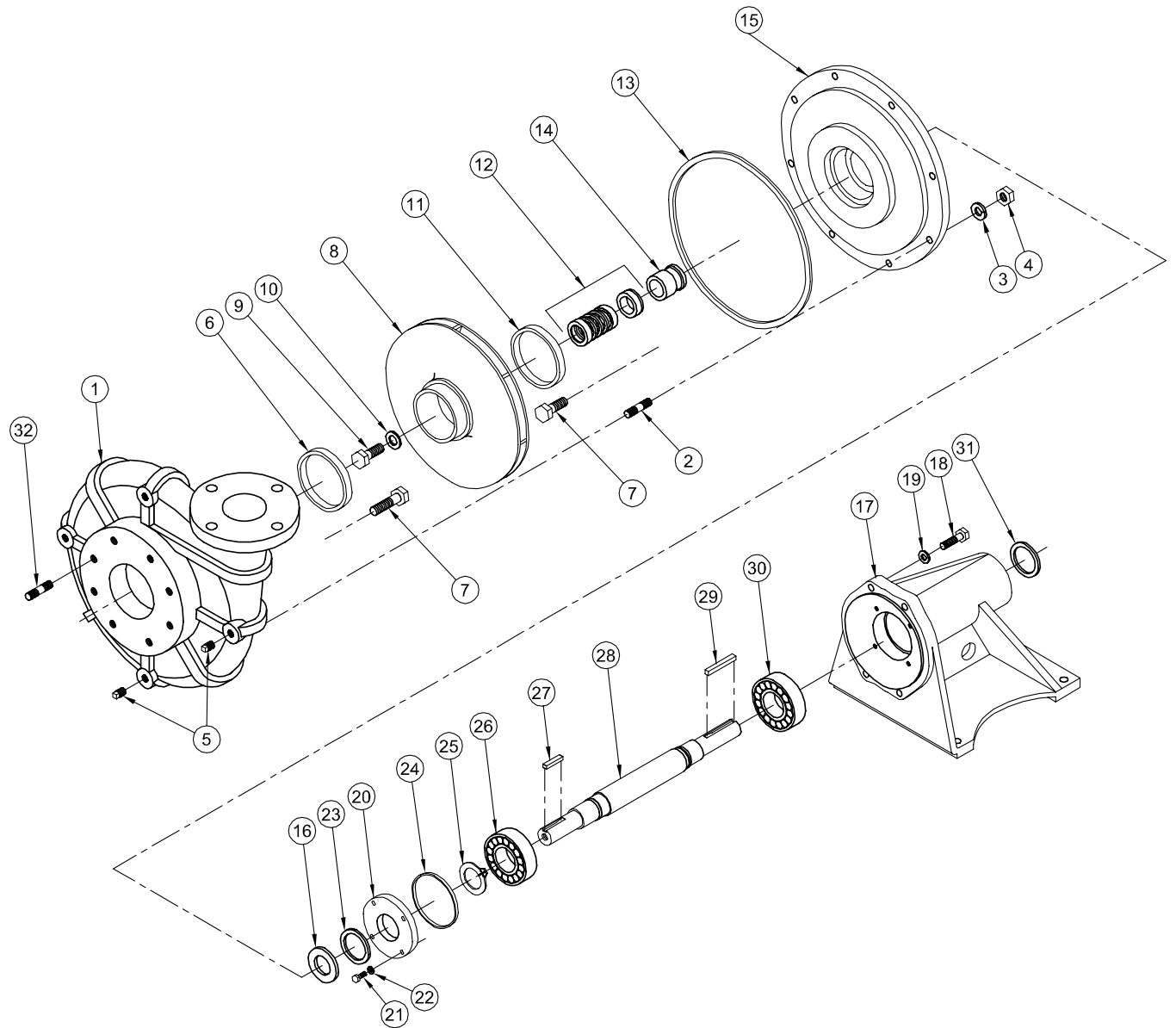

PARTS KIT

Seal Kit P/N: 083562 (‡) 6, 12, 13, 14, 16.

PARTS LIST

Model: 4030HCU P/N: 059459

ITEM	QTY.	PART No.	DESCRIPTION
1	1	059452	Volute
2	8	016409	Stud 1/2-13 x 2.00" Lg
3	8	002608	Lockwasher 1/2"
4	8	15-6-6	Hex Nut 1/2-13, Zp
5	8	003217	Pipe Plug 1/4" NPT
6	1	030645-1 ‡	Wear Ring
7	2	032129	Hex Hd Capscrew 5/16-18 x .50" Lg
8	1	052096	Impeller
9	1	1-68-1	Capscrew 1/2-13 x 1.25" Lg
10	1	030657	Washer
11	1	030645-1	Wear Ring
12	1	031000 ‡	Shaft Seal C/NR/B
13	1	059321 ‡	O-Ring
14	1	030652 ‡	Shaft Sleeve
15	1	052094	Seal Plate
16	1	029915 ‡	Slinger
17	1	052279	Pedestal
18	4	002250	Hex Hd Capscrew 7/16-14 x 1.25" Lg
19	4	002606	Lockwasher 7/16
20	1	030651	Bearing Cap
21	4	002218	Hex Hd Capscrew 5/16-18 x .87" Lg
22	4	002602	Lockwasher 5/16
23	1	024997	Grease Seal
24	1	026997	O-Ring
25	1	030650	Snap Ring
26	1	052098	Bearing
27	1	031388	Key 1/4" Sq x 1.00" Lg
28	1	052277	Shaft
29	1	052317	Key 5/16" Sq x 2.50" Lg
30	1	028998	Bearing
31	1	052097	Grease Seal
32	8	002454	Stud 5/8-11 x 2.75" Lg

BARNES®

BARNES®
PRESSURE **PS** SYSTEMS®

CROWN

burks®

WEINMAN®

DEMING®

PROSSER®

Limited 24 Month Warranty

Crane Pumps & Systems warrants that products of our manufacture will be free of defects in material and workmanship under normal use and service for twenty-four (24) months after manufacture date, when installed and maintained in accordance with our instructions. This warranty gives you specific legal rights, and there may also be other rights which vary from state to state. In the event the product is covered by the Federal Consumer Product Warranties Law (1) the duration of any implied warranties associated with the product by virtue of said law is limited to the same duration as stated herein, (2) this warranty is a LIMITED WARRANTY, and (3) no claims of any nature whatsoever shall be made against us, until the ultimate consumer, his successor, or assigns, notifies us in writing of the defect, and delivers the product and/or defective part(s) freight prepaid to our factory or nearest authorized service station. Some states do not allow limitations on how long an implied warranty lasts, so the above limitation may not apply. **THE SOLE AND EXCLUSIVE REMEDY FOR BREACH OF ANY AND ALL WARRANTIES WITH RESPECT TO ANY PRODUCT SHALL BE TO REPLACE OR REPAIR AT OUR ELECTION, F.O.B. POINT OF MANUFACTURE OR AUTHORIZED REPAIR STATION, SUCH PRODUCTS AND/OR PARTS AS PROVEN DEFECTIVE. THERE SHALL BE NO FURTHER LIABILITY, WHETHER BASED ON WARRANTY, NEGLIGENCE OR OTHERWISE.** Unless expressly stated otherwise, guarantees in the nature of performance specifications furnished in addition to the foregoing material and workmanship warranties on a product manufactured by us, if any, are subject to laboratory tests corrected for field performance. Any additional guarantees, in the nature of performance specifications must be in writing and such writing must be signed by our authorized representative. Due to inaccuracies in field testing if a conflict arises between the results of field testing conducted by or for user, and laboratory tests corrected for field performance, the latter shall control. **RECOMMENDATIONS FOR SPECIAL APPLICATIONS OR THOSE RESULTING FROM SYSTEMS ANALYSES AND EVALUATIONS WE CONDUCT WILL BE BASED ON OUR BEST AVAILABLE EXPERIENCE AND PUBLISHED INDUSTRY INFORMATION. SUCH RECOMMENDATIONS DO NOT CONSTITUTE A WARRANTY OF SATISFACTORY PERFORMANCE AND NO SUCH WARRANTY IS GIVEN.**

This warranty shall not apply when damage is caused by (a) improper installation, (b) improper voltage (c) lightning (d) excessive sand or other abrasive material (e) scale or corrosion build-up due to excessive chemical content. Any modification of the original equipment will also void the warranty. We will not be responsible for loss, damage or labor cost due to interruption of service caused by defective parts. Neither will we accept charges incurred by others without our prior written approval.

This warranty is void if our inspection reveals the product was used in a manner inconsistent with normal industry practice and/or our specific recommendations. The purchaser is responsible for communication of all necessary information regarding the application and use of the product. **UNDER NO CIRCUMSTANCES WILL WE BE RESPONSIBLE FOR ANY OTHER DIRECT OR CONSEQUENTIAL DAMAGES, INCLUDING BUT NOT LIMITED TO TRAVEL EXPENSES, RENTED EQUIPMENT, OUTSIDE CONTRACTOR FEES, UNAUTHORIZED REPAIR SHOP EXPENSES, LOST PROFITS, LOST INCOME, LABOR CHARGES, DELAYS IN PRODUCTION, IDLE PRODUCTION, WHICH DAMAGES ARE CAUSED BY ANY DEFECTS IN MATERIAL AND/OR WORKMANSHIP AND/OR DAMAGE OR DELAYS IN SHIPMENT. THIS WARRANTY IS EXPRESSLY IN LIEU OF ANY OTHER EXPRESS OR IMPLIED WARRANTY, INCLUDING ANY WARRANTY OF MERCHANTABILITY OR FITNESS FOR A PARTICULAR PURPOSE.**

No rights extended under this warranty shall be assigned to any other person, whether by operation of law or otherwise, without our prior written approval.

CRANE®

A Crane Co. Company

PUMPS & SYSTEMS

420 Third Street
Piqua, Ohio 45356
Phone: (937) 778-8947
Fax: (937) 773-7157
www.cranepumps.com

83 West Drive, Brampton
Ontario, Canada L6T 2J6
Phone: (905) 457-6223
Fax: (905) 457-2650

**IMPORTANT!
WARRANTY REGISTRATION**

Your product is covered by the enclosed Warranty.
To complete the Warranty Registration Form go to:

<http://www.cranepumps.com/ProductRegistration/>

If you have a claim under the provision of the warranty, contact your local
Crane Pumps & Systems, Inc. Distributor.

RETURNED GOODS

**RETURN OF MERCHANDISE REQUIRES A "RETURNED GOODS AUTHORIZATION".
CONTACT YOUR LOCAL CRANE PUMPS & SYSTEMS, INC. DISTRIBUTOR.**



**Products Returned Must Be Cleaned, Sanitized,
Or Decontaminated As Necessary Prior To Shipment,
To Insure That Employees Will Not Be Exposed To Health
Hazards In Handling Said Material. All Applicable Laws
And Regulations Shall Apply.**