

1½", 2" & 3" Discharge

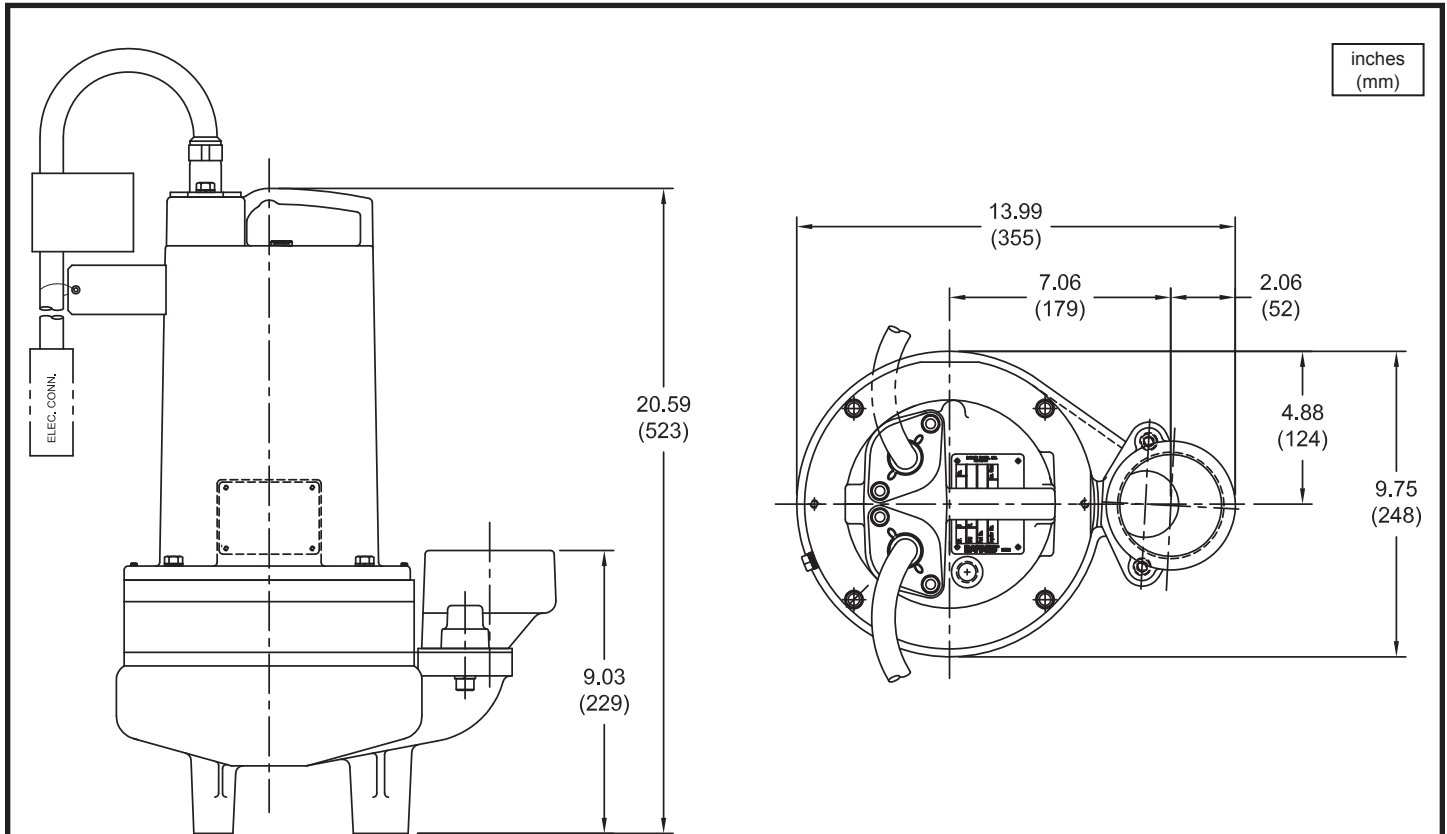

MODEL NO	PART NO	HP	VOLT/PH	Hz	RPM (Nom)	NEMA START CODE	INSUL. CLASS	FULL LOAD AMPS	LOCKED ROTOR AMPS	CORD SIZE	CORD TYPE	CORD O.D. inch (mm)
3SE514DS	104897	0.5	120/1	60	1750	F	B	11.6	21.3	14/3	SJTOW	0.375 (9.5)
3SE524DS	104898	0.5	240/1	60	1750	J	B	5.9	14.9	14/3	SOW	0.530 (13.5)
3SE594DS	104899	0.5	200-240/3	60	1750	H/L	B	3.2/3.0	9.8/11.0	14/4	SOW	0.570 (14.5)
3SE544DS	104900	0.5	480/3	60	1750	K	B	1.5	5.3	14/4	SOW	0.570 (14.5)
3SE554DS	104901	0.5	600/3	60	1750	H	B	1.0	3.4	14/4	SOW	0.570 (14.5)
3SE774DS	104906	0.75	200-240/1	60	1750	G/K	F	7.4/7.0	21.5/25.8	14/3	SOW	0.530 (13.5)
3SE794DS	104907	0.75	200-240/3	60	1750	H/K	F	4.8/4.5	13.7/15.4	14/4	SOW	0.570 (14.5)
3SE744DS	104908	0.75	480/3	60	1750	K	F	2.2	7.7	14/4	SOW	0.570 (14.5)
3SE754DS	104909	0.75	600/3	60	1750	L	F	1.5	7.2	14/4	SOW	0.570 (14.5)
3SE1074DS	104914	1.0	200-240/1	60	1750	D/G	F	8.8/8.3	21.5/25.8	14/3	SOW	0.530 (13.5)
3SE1094DS	104915	1.0	200-240/3	60	1750	E/H	F	5.14/4.9	13.7/15.4	14/3	SOW	0.570 (14.5)
3SE1044DS	104916	1.0	480/3	60	1750	H	F	2.4	7.7	14/4	SOW	0.570 (14.5)
3SE1054DS	104917	1.0	600/3	60	1750	J	F	1.9	7.2	14/4	SOW	0.570 (14.5)

OPTIONAL - Temperature sensor cord for 3 phase models is 14/3 SOW, 0.530 (13.5mm) O.D.

OPTIONAL - Moisture sensor cord is 18/5 SOW, 0.470 (11.9mm) O.D.

OPTIONAL - Moisture & Temperature sensor cord for 3 phase models is 18/5 SOW, 0.470 (11.9mm) O.D.

IMPORTANT !

- 1.) PUMP MAY BE OPERATED "DRY" FOR EXTENDED PERIODS WITHOUT DAMAGE TO MOTOR AND/OR SEALS.
- 2.) INSTALLATIONS SUCH AS DECORATIVE FOUNTAINS OR WATER FEATURES PROVIDED FOR VISUAL ENJOYMENT MUST BE INSTALLED IN ACCORDANCE WITH THE NATIONAL ELECTRIC CODE ANSI/NFPA 70 AND/OR THE AUTHORITY HAVING JURISDICTION. THIS PUMP IS NOT INTENDED FOR USE IN SWIMMING POOLS, RECREATIONAL WATER PARKS, OR INSTALLATIONS IN WHICH HUMAN CONTACT WITH PUMPED MEDIA IS A COMMON OCCURRENCE.

Series 3SE-DS

Performance Curve

0.5, 0.75 & 1.0HP, 1750RPM, 60Hz

BARNES®

www.cranepumps.com

1½", 2" & 3" Discharge

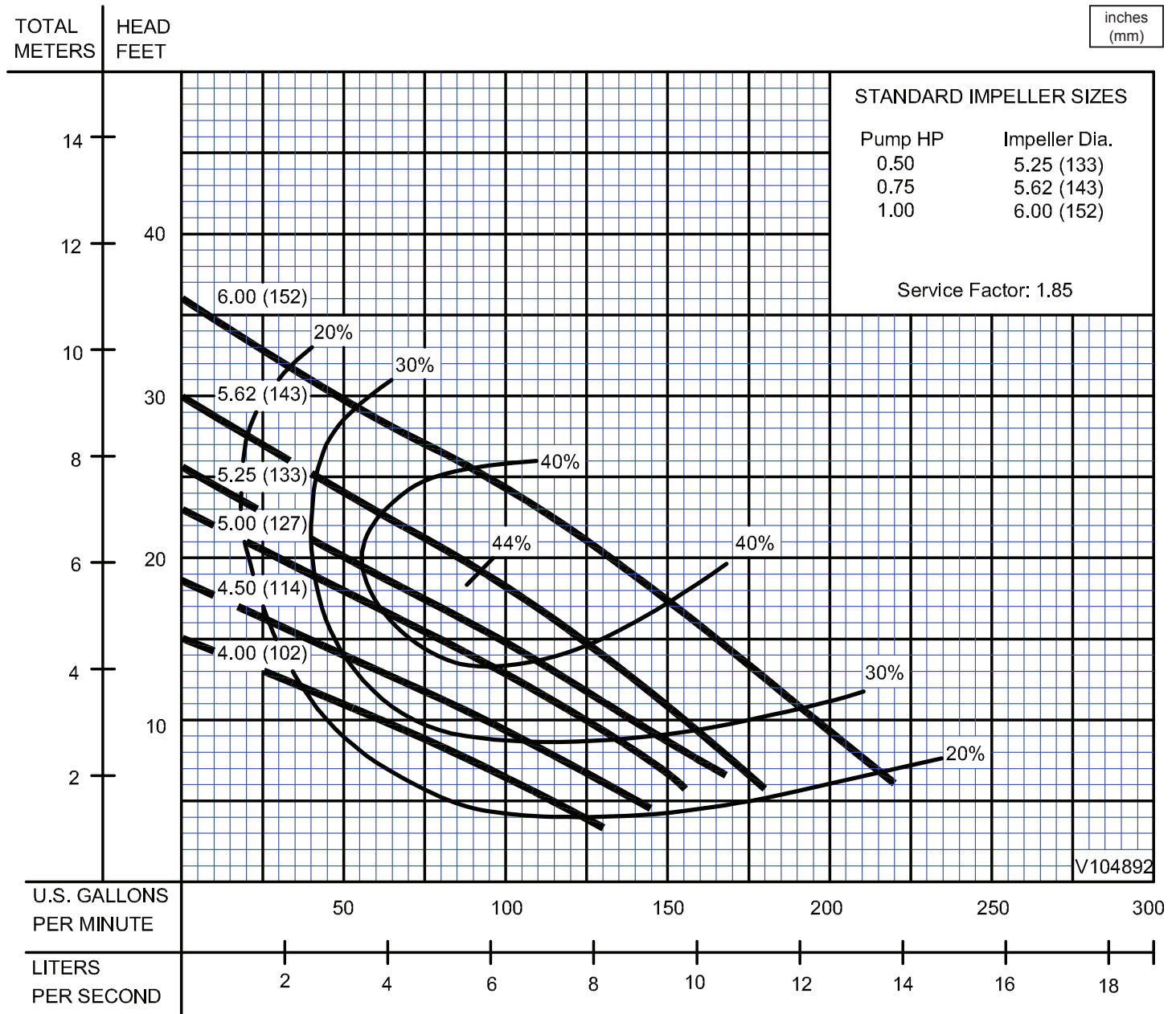

Testing is performed with water, specific gravity 1.0 @ 68° F @ (20°C), other fluids may vary performance

SECTION 1B
PAGE 42
DATE 6/04

CRANE®

A Crane Co. Company

PUMPS & SYSTEMS

USA: (937) 778-8947 • Canada: (905) 457-6223 • International: (937) 615-3598