

**41 Gallon Basin Package Includes:**

- One - SE411 or SEV412, or SE421**  
Heavy duty sewage ejector pump
- One - Level Control**  
Mechanical switch molded inside of a waterproof float. Single control turns pump on and off automatically. Piggy-Back design.
- One - Polyethylene Basin**  
20" (457mm) Dia. x 30" (762mm) Deep, with 4" (102mm) Inlet Hole.  
25" (635mm) Dia. x 24" (610mm) Deep, with 4" (102mm) Inlet Hole.
- One - Split Cover with Floatree**  
2" (51mm) vent, 2" (51mm) Discharge and cord openings
- One - 2" (51mm) Vertical Compression Check Valve**

Sch. 40 Discharge pipe, cover gasket, cover hardware, cord grommet, discharge and vent grommets also included.

**FEATURES:**

- Floatree design for easy float maintenance; Flange includes provision for optional alarm float.
- Split cover allows simplified basin access
- Sidewall ribs lock basin in place when concrete floor is poured
- Inlet hubs easily connect to piping with flexible rubber connectors (Provided by others)
- Ribbed floor limits pump rotation

**NOTE**

Pre-Assembled units contain water soluble packing inside. There is no need to remove it.

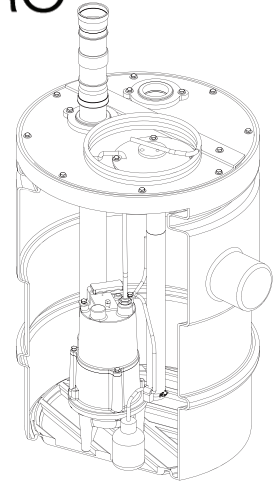

**DESCRIPTION:**

SIMPLEX SYSTEMS (ONE PUMP) ARE GOOD FOR RESIDENTIAL AND COMMERCIAL SEWAGE OR SUMP APPLICATIONS. THEY ARE DESIGNED TO HANDLE WASTES FROM LAVATORIES, LAUNDRY TUBS, FLOOR DRAINS, WATER CLOSETS, ETC., AND WILL PUMP THE WATER FROM BELOW GROUND "UPHILL" TO THE SEWER.



**WARNING:**

CANCER AND REPRODUCTIVE HARM -  
WWW.P65WARNINGS.CA.GOV

**TOTAL HEAD METERS** | **HEAD FEET**

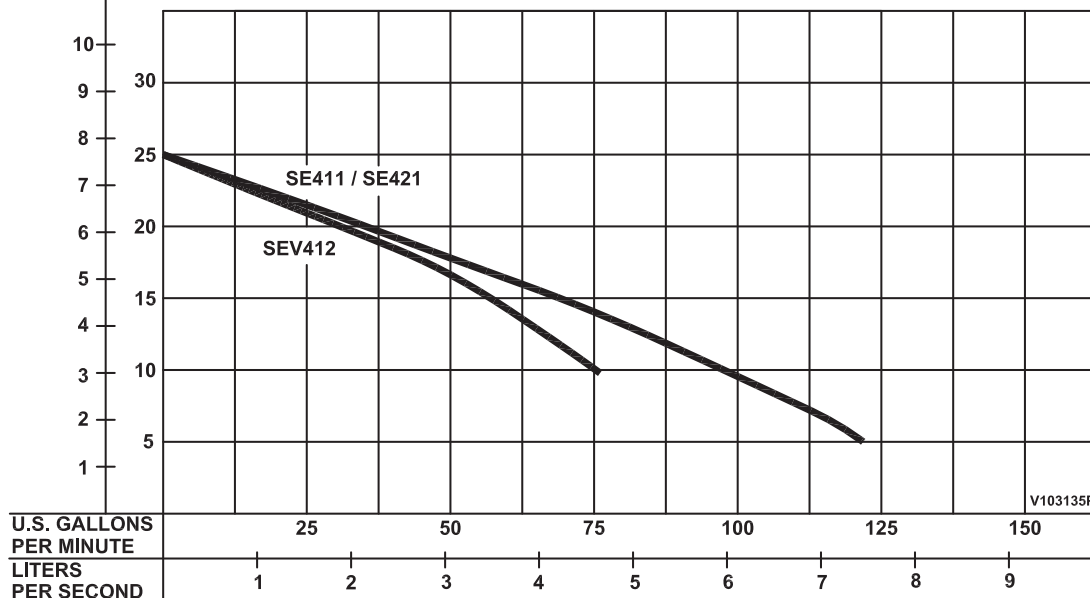

Testing is performed with water specific gravity of 1.0 @ 68°F (20°C), other fluids may vary performance

# Series SE & SEV-ASP

Kit Simplex Systems  
Pre-Assembled - 41 gal.

## Packaged Systems

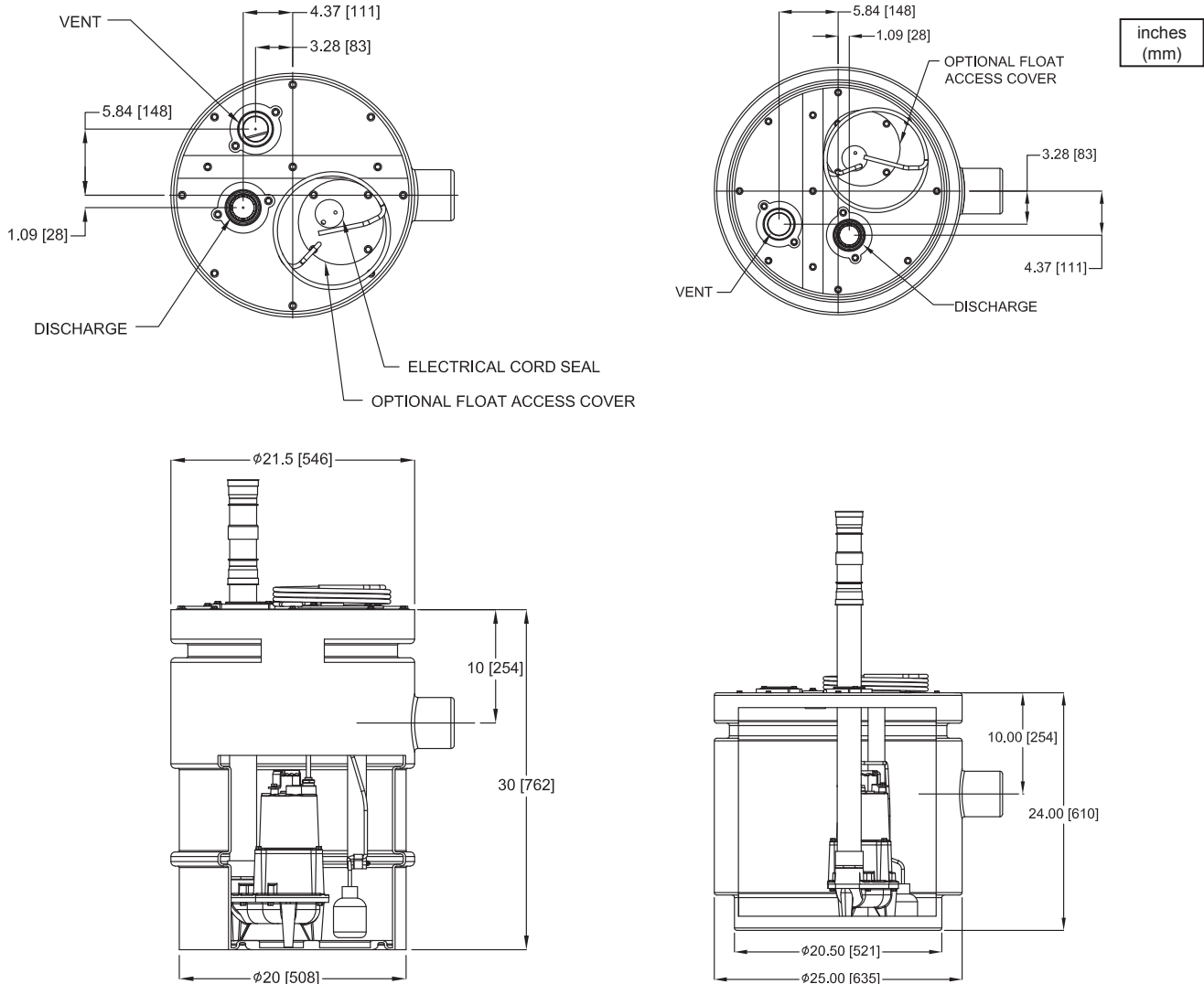

41 Gallon Sewage Station - Configuration Matrix

Configuration	Tank Type		Configuration		Pump			Voltage **	
	20" Dia. x 30" Dp.	25" Dia. x 24" Dp.	Basin Kit *	Pre-Assembled	SEV412	SE411	SE421	120V	230V
126914	X			X	X			X	
126915	X			X		X		X	
126916	X			X			X		X
126920		X		X	X			X	
126921		X		X		X		X	
126922		X		X			X		X

\* Basin Kits are less the pump. A pump must be ordered separately.

### IMPORTANT !

- 1.) PUMP MAY BE OPERATED "DRY" FOR EXTENDED PERIODS WITHOUT DAMAGE TO MOTOR AND/OR SEALS.
- 2.) INSTALLATIONS SUCH AS DECORATIVE FOUNTAINS OR WATER FEATURES PROVIDED FOR VISUAL ENJOYMENT MUST BE INSTALLED IN ACCORDANCE WITH THE NATIONAL ELECTRIC CODE ANSI/NFPA 70 AND/OR THE AUTHORITY HAVING JURISDICTION. THIS PUMP IS NOT INTENDED FOR USE IN SWIMMING POOLS, RECREATIONAL WATER PARKS, OR INSTALLATIONS IN WHICH HUMAN CONTACT WITH PUMPED MEDIA IS A COMMON OCCURRENCE.