



## Electrical Warnings / Advertencias Eléctricas

Failure to follow these precautions could result in serious injury or death. Replace the float switch immediately if cable becomes damaged or severed. Keep these instructions with warranty after installation. This product must be installed in accordance with National Electric Code, ANSI/NFPA 70 so as to prevent moisture from entering or accumulating within boxes, conduit bodies, fittings, float housing, or cable.

	<b>WARNING ELECTRICAL SHOCK HAZARD</b> Disconnect power before installing or servicing this product. A qualified service person must install and service this product according to applicable electrical and plumbing codes.		<b>WARNING EXPLOSION OR FIRE HAZARD</b> Do not use this product with flammable liquids. Do not install in hazardous locations as defined by National Electrical Code, ANSI/NFPA 70.
--	---	---	--

No obedecer estas precauciones podría resultar en lesiones serias o mortales. Reemplace el interruptor de flotador de inmediato si el cable está dañado o partido. Después de la instalación, guardar estas instrucciones junto con la garantía. Este producto debe ser instalado siguiendo el Código Eléctrico Nacional de EE.UU., ANSI/NFPA 70, para evitar la entrada o acumulación de humedad en cajas de conexión, conductos, acoples, carcasa del interruptor (flotador) o el cable.

	<b>ADVERTENCIA RIESGO DE CHOQUE ELÉCTRICO</b> Desconecte el cable de alimentación antes de instalar este producto o de hacerle mantenimiento. La instalación y el mantenimiento de este producto deben ser efectuados por personal idóneo siguiendo las normas aplicables en cuanto a instalaciones eléctricas y plomería.		<b>ADVERTENCIA RIESGO DE INCENDIO O EXPLOSIÓN</b> No utilice este producto con líquidos inflamables. No lo instale en lugares peligrosos definidos como tales en el Código Eléctrico Nacional de Estados Unidos, ANSI/NFPA 70.
--	---	---	---

## Wiring Diagrams

NOTE:  
INFEED ALARM POWER MUST MATCH VOLTAGE RATING ON THE FRONT OF THE ALARM.

INFEED POWER  
120 VAC ONLY

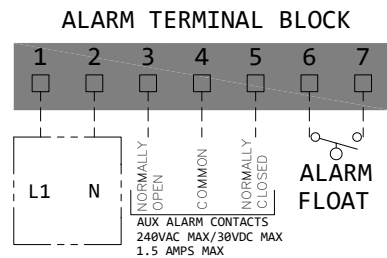

NOTE:  
AUX ALARM CONTACTS USED TO TRIGGER SECONDARY REMOTE DEVICE IF NEEDED. NON POWERED DRY CONTACT

### ORDERABLE OPTION

#### PUMP TERMINAL BLOCK

INFEED POWER  
120/208/240 VAC

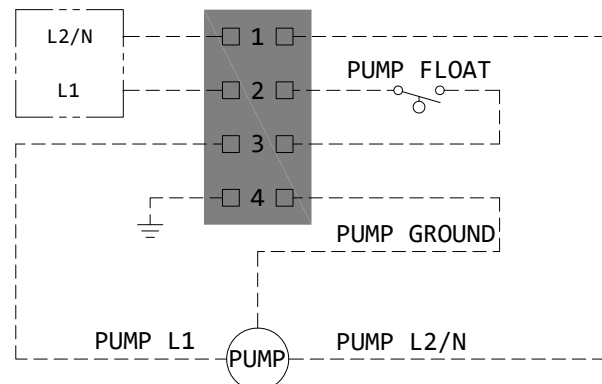

NOTE:  
INFEED PUMP POWER MUST MATCH PUMP VOLTAGE.

### CSI CONTROLS® FIVE-YEAR LIMITED WARRANTY

Five-Year Limited Warranty.  
For complete terms and conditions, please visit [www.csicontrols.com](http://www.csicontrols.com).

### GARANTÍA LIMITADA DE CINCO AÑOS DE CSI CONTROLS®

Cinco años de garantía limitada.  
Para consultar los términos y condiciones, visite el portal [www.csicontrols.com](http://www.csicontrols.com).

## Items Needed / Elementos Necesarios

Included with CSION® 3R Alarm  
Viene con la alarma CSION® 3R Alarm

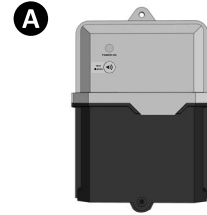

Included with Optional Float Switch  
Viene con el interruptor de flotador opcional

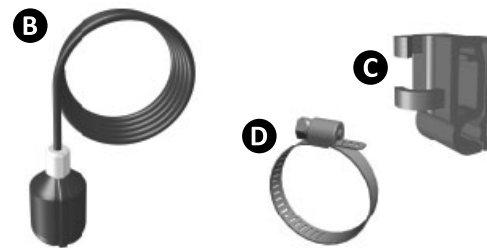

Not included  
No incluido



## Specifications Especificaciones

<b>Voltage</b>	<b>120 VAC Model</b> Primary: 120 VAC, 50/60 Hz, 3.8 watts max. (alarm condition) Secondary: 9 VDC	<b>Voltaje</b>	<b>Modelo de 120 V CA</b> Primario: 120 V CA, 50/60 Hz, 3,8 watts máx. (estado de alarma) Secundario: 9 V CC
<b>Enclosure</b>	<b>Indoor/Outdoor</b>	<b>Gabinete</b>	<b>Interior/Exterior</b>

## CSION® 3R Alarm / Alarma

### Installation Instructions / Instrucciones de instalación

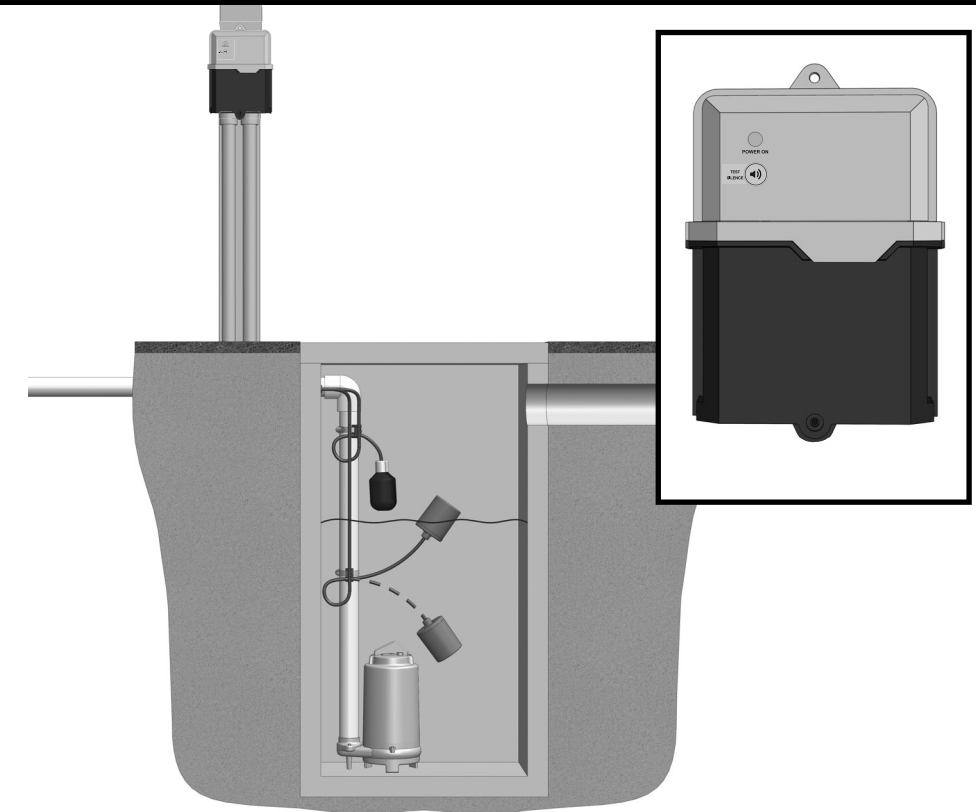

#### English

This alarm system monitors liquid levels in lift pump chambers, sump pump basins, holding tanks, sewage, agricultural, and other water applications.

The CSION® 3R indoor/outdoor alarm can serve as a high or low level alarm depending on the float switch model used. This easy-to-install alarm features an innovative, sleek 2-color molded enclosure which integrates the LED translucent beacon (LED available in red or yellow).

The alarm sounds and the upper half of the housing illuminates when a potentially threatening liquid level condition occurs. The audible alarm can be silenced by pressing the Test/Silence button, but the alarm light will remain on until the condition is remedied. Once the condition is cleared, the alarm will automatically reset. A green "power on" light indicates power to the alarm panel.

#### Español

Este sistema de alarma vigila la altura del líquido en cámaras de bombas aspirantes, en cubetas de bombas de sumidero, en tanques de retención, y en aplicaciones como aguas residuales, agricultura y otros sistemas de aguas.

La alarma para uso interior y exterior CSION® 3R puede utilizarse como alarma de nivel alto o bajo, dependiendo del modelo del interruptor de nivel. Esta alarma es fácil de instalar y trae una innovadora caja moldeada de dos colores, que integra la luz LED roja translúcida de aviso (y también una luz de aviso de color amarillo).

Ante una condición potencialmente peligrosa del nivel de líquido, la bocina de la alarma suena y la parte superior de la caja se ilumina. La alarma audible se silencia pulsando el botón de prueba/silencio (Test/Silence) quedando encendida la luz hasta que se resuelva la situación. La alarma retorna automáticamente a su condición inicial una vez se resuelva la condición que la activó. La luz verde de encendido ("power on") indica que hay alimentación al panel de la alarma.



# CSI Controls®

+ 1-800-746-6287

techsupport@sjeinc.com

[www.csicontrols.com](http://www.csicontrols.com)

Technical Support Hours: Monday - Friday, 7 A.M. to 6 P.M. Central Time  
Soporte técnico, Horario: lunes a viernes, 7 A.M. a 6 P.M. hora del Centro

**1** Mount the alarm enclosure using existing upper and lower mounting tabs.

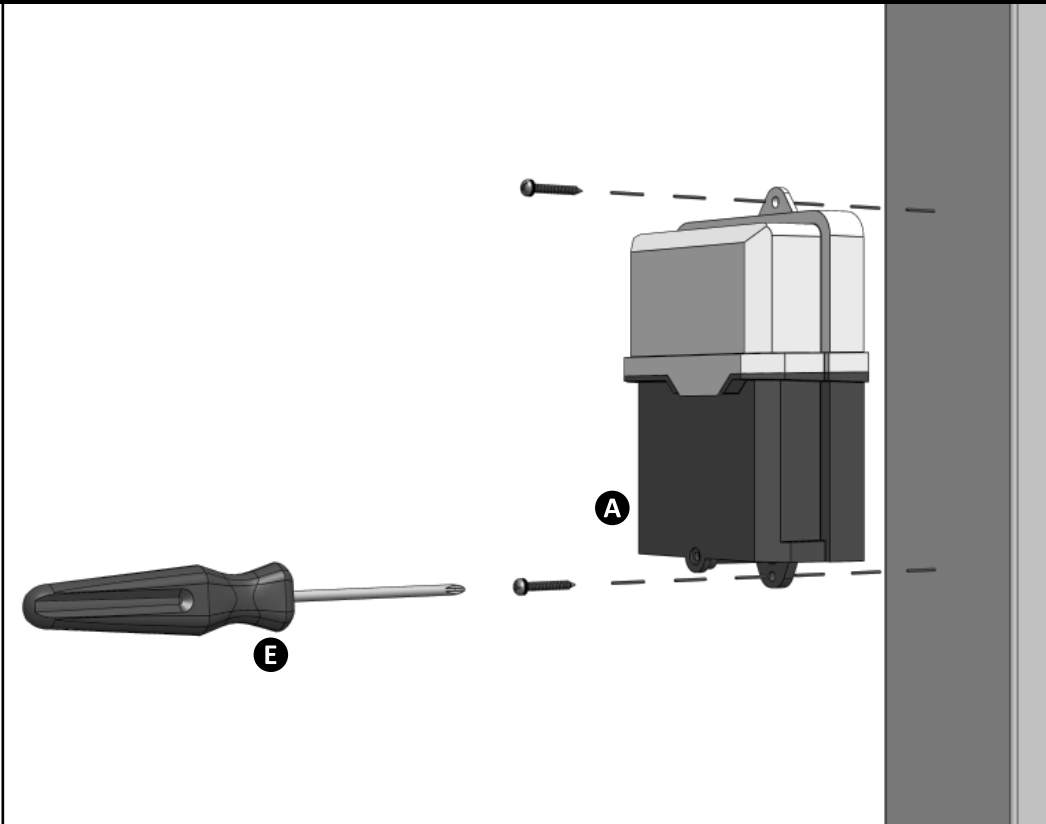

**2** Install float switch at desired activation level.

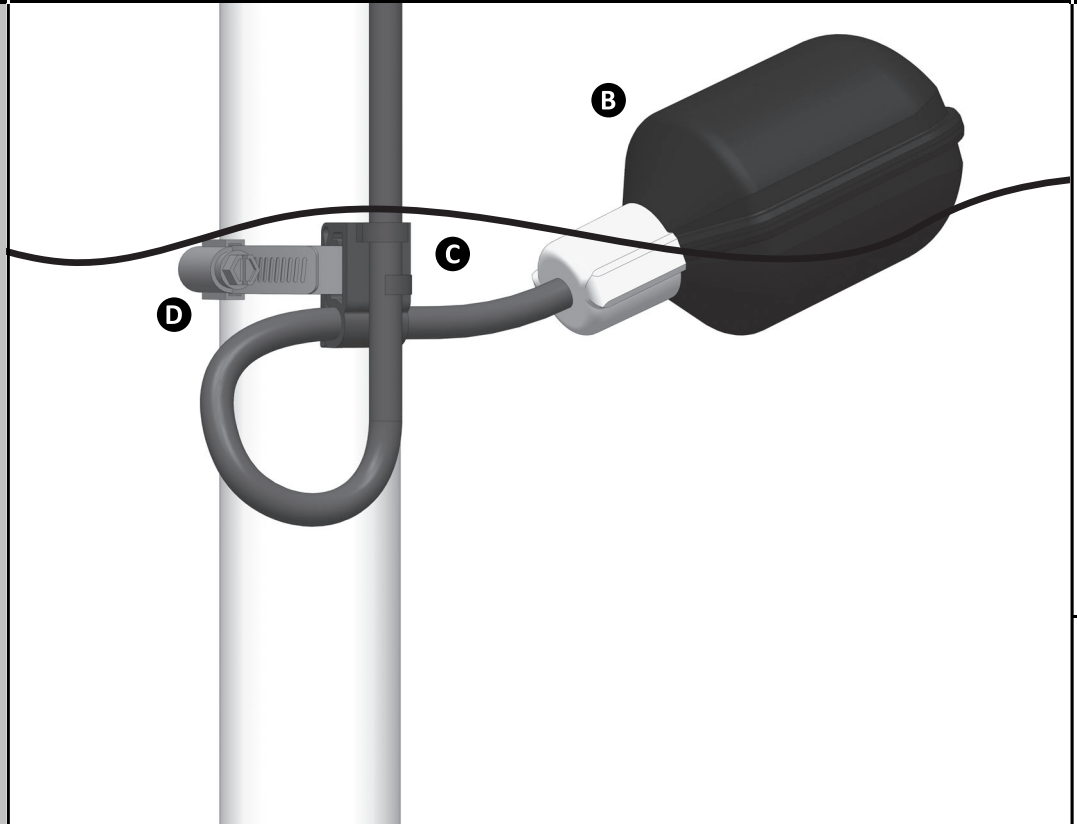

**3** Remove screw from front of lower cover. Lift bottom of lower cover out slightly. Slide lower cover down until it is clear of the upper cover and remove. Determine "conduit-in" location on alarm. See bottom of enclosure for cord placement indicator marks. Drill holes for conduit entry.

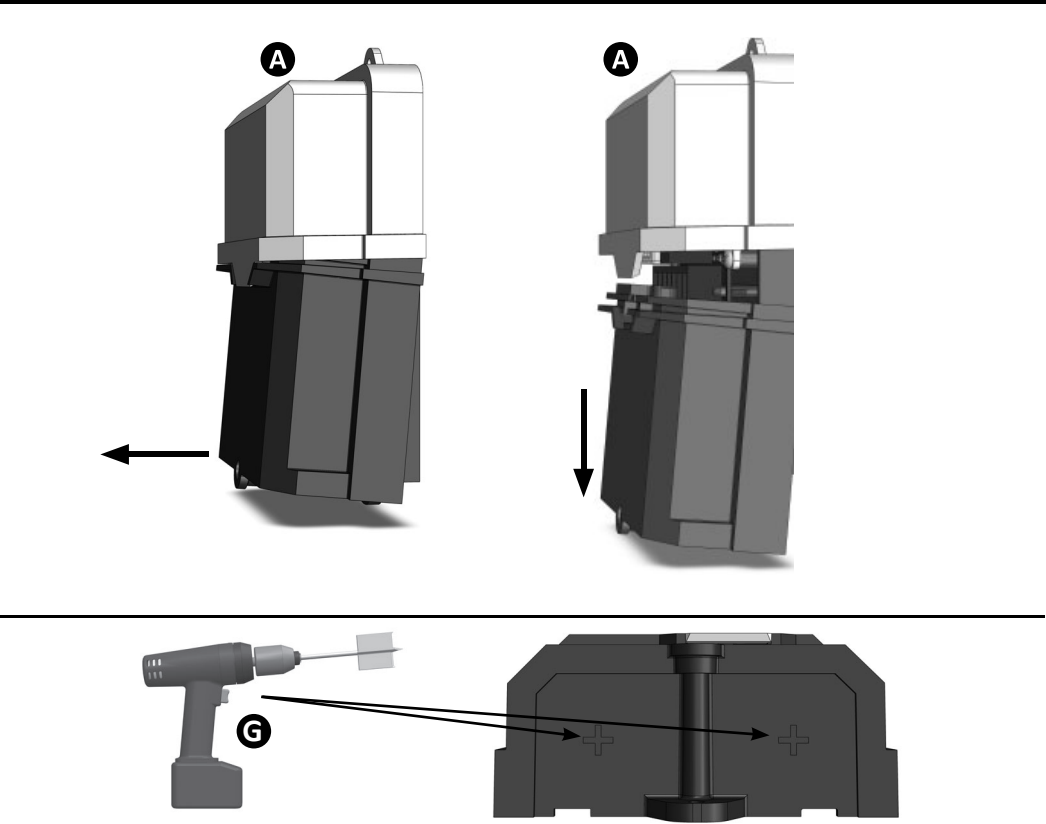

**4** Bring float switch and power cable through conduit and wire to 7 position terminal block. Connect ground wire to ground termination post. **NOTE:** Seal conduit to prevent moisture or gas from entering enclosure.

**5** Restore power and check alarm operation after installation (high level application shown).

**6** Test alarm weekly to insure proper operation.

