

### Medium Sump or Drainage Pumps

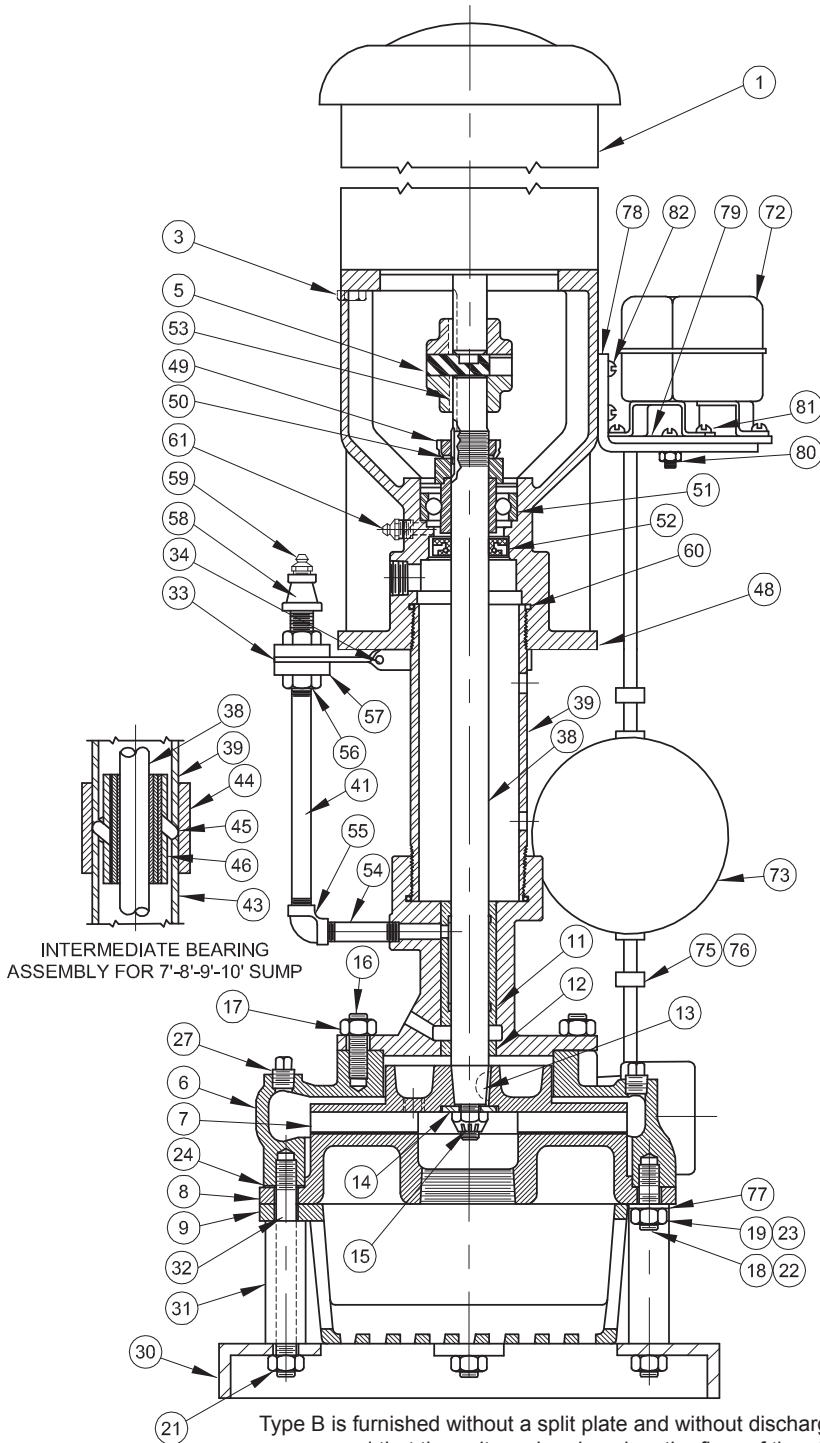

Type B is furnished without a split plate and without discharge pipe, so arranged that the unit can be placed on the floor of the pit.

ITEM No.	DESCRIPTION
1	Motor
3	Cap Screws
5	Coupling
6	Casing
7	Impeller
8	Suction Head
9	Strainer
10	Support Head
11	Bottom Shaft Bearing
12	Choker Ring
13	Woodruff Key
14	Impeller Washer
15	Impeller Hug Nut
16	Studs
17	Nuts
18	Studs (for Items 6-8-9 size 1-2)
19	Nuts (Item 18)
21	Nuts
22	Studs (for Items 6-8-9 size 3-4-5)
23	Nuts (item 22)
24	Suction Head Gasket
27	Pipe Plugs
30	Base
31	Nipples
32	Studs
33	Grease Pipe Holder
34	Bolt & Nut
38	Shaft
39	Column Pipe
40	Discharge Pipe
41	Grease Pipe
43	Column Pipe (Bottom Section)
44	Pipe Coupling
45	Intermediate Bearing Housing
46	Graphalloy Bearing
48	Motor Mounting
49	Shaft Adjusting Nut
50	Lockwasher
51	Thrust Bearing
52	Grease Seal
53	Shaft Key
54	Nipple
55	Elbow
56	Pipe Nuts
57	Washers
58	Reducer Coupling
59	Grease Fitting
60	Shims (When Required)
61	Grease Fitting
72	Float Switch
73	Float
74	Float Rod
75	Float Rod Collar
76	Set Screw (Headless)
77	Float Rod Guide
78	Switch Bracket
79	Switch Mounting Plate
80	Machine Screw & Nut
81	Machine Screws
82	Machine Screws



**WARNING:**  
CANCER AND REPRODUCTIVE HARM -  
WWW.P65WARNINGS.CA.GOV