

Foot Valve

Model 60SE



Flomatic Corporation

Sizes 1" & 1-1/4" / 25 mm & 32 mm

Materials

Enviro Check®

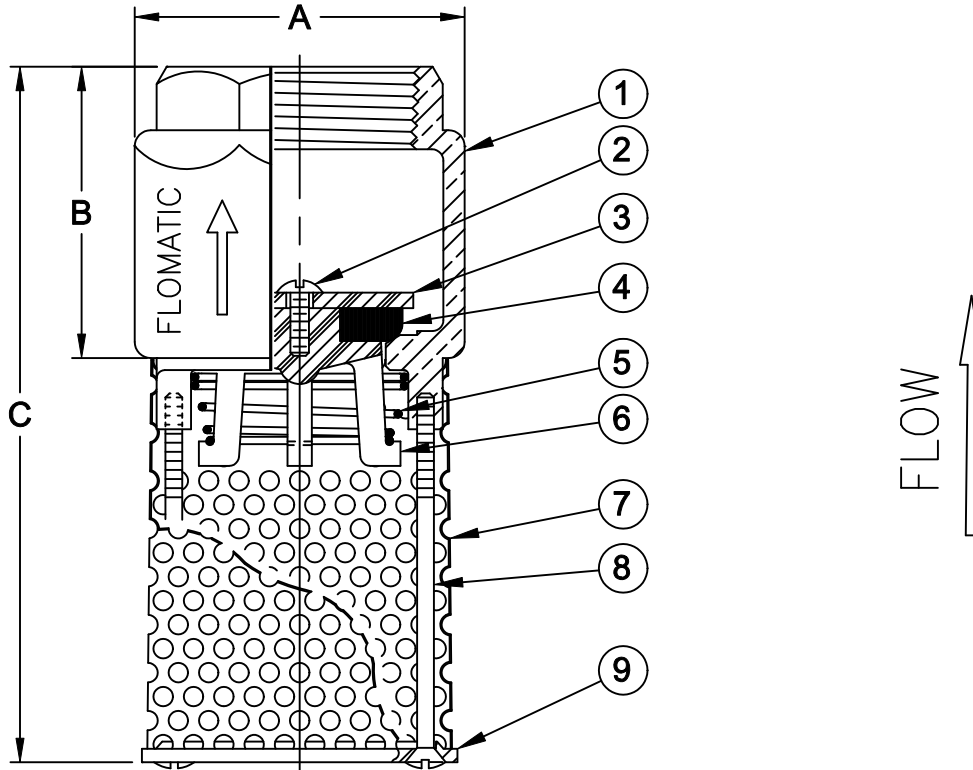

Open Area: 35-50%
 Max Temp 180°F (82°C)
 Max Pressure 250psi (18bar)

Item #	Qty	Description	Material	ASTM
1	1	Body	Unleaded Bronze	C89833
2	1	Screw	Stainless Steel	18-8
3	1	Flat Washer	Stainless Steel	18-8
4	1	Disc	Buna-n	-----
5	1	Spring	Stainless Steel	302
6	1	Guide	Delrin	-----
7	1	Screen	Stainless Steel	18-8
8	2	Screw	Stainless Steel	18-8
9	1	Cap	Polycarbonate	-----

Dimensions

Patent # 4,971,093

Size		Part #	A		B		C		Weight	
inch	mm		inch	mm	inch	mm	inch	mm	lbs	kg
1	25	4101E	1-29/32	49	1-25/32	45	4-59/64	125	51/64	.36
1-1/4	32	4103E	2-17/64	57	1-55/64	47	5	127	1	.45

Flomatic Corporation can accept no responsibility for possible errors in catalogues, brochures and other printed material. Flomatic Corporation reserves the right to alter its products without notices. This also applies to product already agreed. All trademarks in this material are property of the respective companies. All right reserved. ©2011 Flomatic Corporation. The drawings & information on this drawing sheet are the sole & exclusive property of Flomatic Corporation. Any reproduction, distribution, display or use of these drawings or information in whole or in part without written authorization of Flomatic Corporation is strictly prohibited.



May 12, 1995
 Dwg No: S4101E-4 Rev: G (8/11)

FLOMATIC CORPORATION
 GLENS FALLS, N.Y. 12801
 PHONE (518) 761-9797
 FAX (518) 761-9798

Foot Valve

Sizes 1-1/2" / 40 mm

Model 60SE



Flomatic Corporation

Materials

Enviro Check®

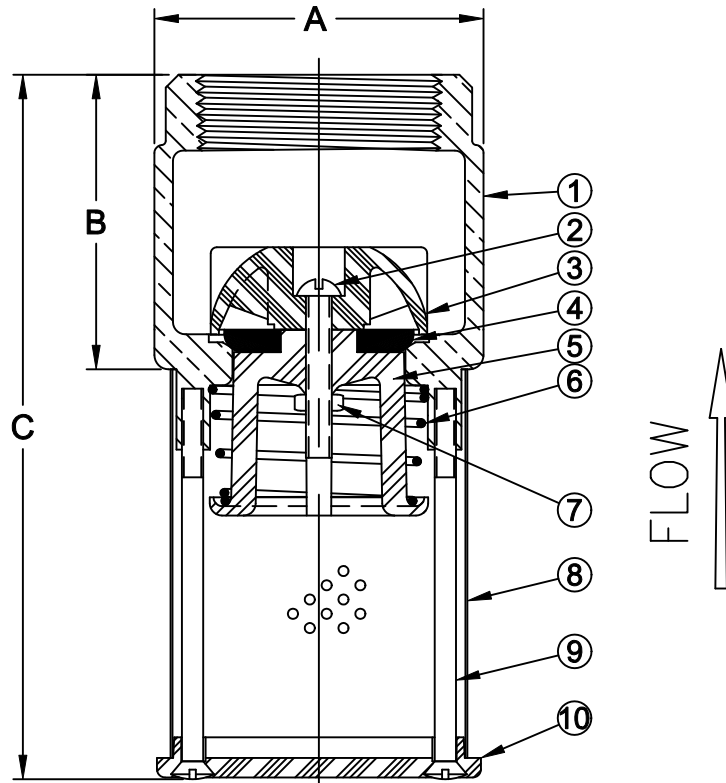

Open Area: 35-50%
 Max Temp 180°F (82°C)
 Max Pressure 250psi (18bar)

Item #	Qty	Description	Material	ASTM
1	1	Body	Unleaded Bronze	C89833
2	1	Screw	Stainless Steel	18-8
3	1	Dome	Delrin	-----
4	1	Disc	Buna-n	-----
5	1	Guide	Delrin	-----
6	1	Spring	Stainless Steel	302
7	1	Nut	Stainless Steel	18-8
8	1	Screen	Stainless Steel	18-8
9	2	Screw	Stainless Steel	18-8
10	1	Cap	Delrin	-----

Dimensions

Size		Part #	A		B		C		Weight	
inch	mm		inch	mm	inch	mm	inch	mm	lbs	kg
1-1/2	40	4104E	2-33/64	65	2-17/64	58	5-7/16	138	1-19/32	.73

Flomatic Corporation can accept no responsibility for possible errors in catalogues, brochures and other printed material. Flomatic Corporation reserves the right to alter its products without notices. This also applies to product already agreed. All trademarks in this material are property of the respective companies. All right reserved. ©2011 Flomatic Corporation. The drawings & information on this drawing sheet are the sole & exclusive property of Flomatic Corporation. Any reproduction, distribution, display or use of these drawings or information in whole or in part without written authorization of Flomatic Corporation is strictly prohibited.



January 15, 2004
 Dwg No: S4104E Rev: B (8/11)

FLOMATIC CORPORATION
 GLENS FALLS, N.Y. 12801
 PHONE (518) 761-9797
 FAX (518) 761-9798