

Ductile Iron Check Valve

Sizes 2-1/2" / 65 mm

Model 80DI **FLOMATIC**[®]

Flomatic Corporation

Materials

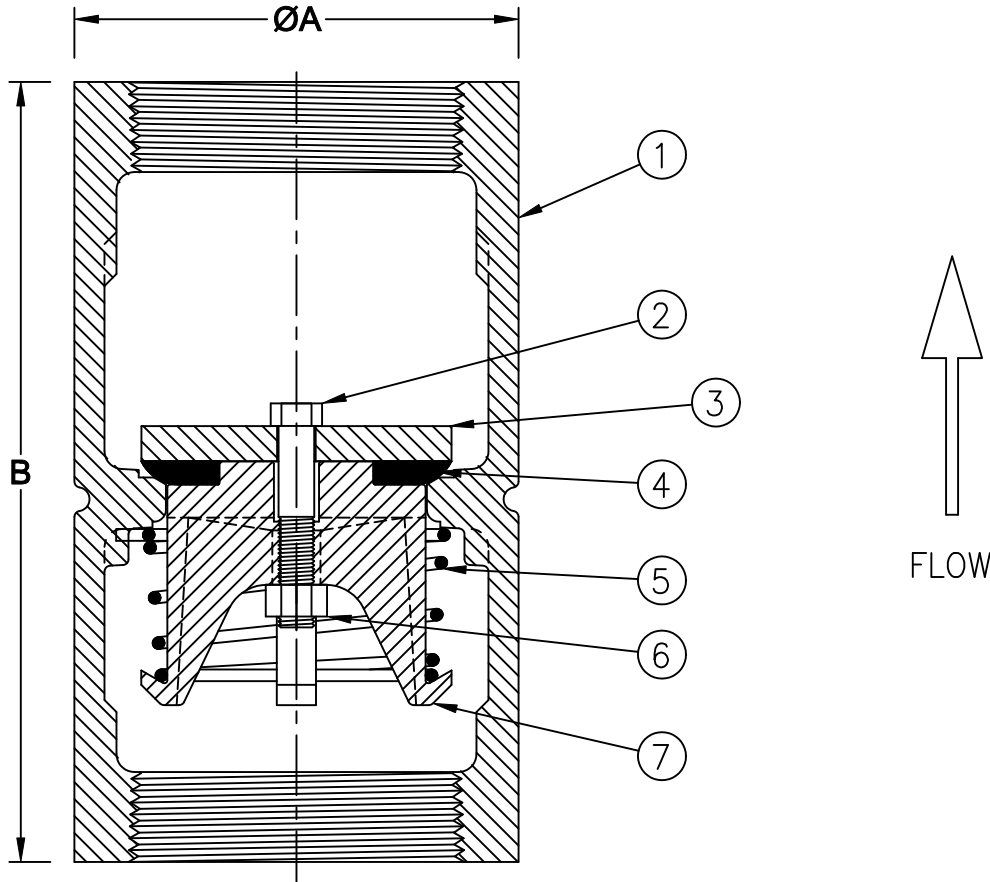

Item #	Qty	Description	Material	ASTM
1	1	Body (Epoxy Coated)	Ductile Iron	60-40-18
2	1	Bolt	Stainless Steel	18-8
3	1	Washer	Stainless Steel	304
4	1	Rubber Disc	Buna-n	-----
5	1	Spring	Stainless Steel	302
6	1	Nut	Stainless Steel	18-8
7	1	Guide (Epoxy Coated)	Federalloy	I-836-FL

Dimensions

Max Temp 180°F (82°C)
Max Pressure 400psi (24bar)

Size		Part #	A		B		Weight	
Inch	mm		Inch	mm	Inch	mm	lbs	kg
2-1/2	65	7936	3-5/8	92	7-3/16	183	8.5	4

Flomatic Corporation can accept no responsibility for possible errors in catalogues, brochures and other printed material. Flomatic Corporation reserves the right to alter its products without notices. This also applies to product already agreed. All trademarks in this material are property of the respective companies. All right reserved. ©2011 Flomatic Corporation. The drawings & information on this drawing sheet are the sole & exclusive property of Flomatic Corporation. Any reproduction, distribution, display or use of these drawings or information in whole or in part without written authorization of Flomatic Corporation is strictly prohibited.