

NON-CORROSIVE TRANSFER PUMPS - A SERIES

FEATURES

- High-tech, non-corrosive plastic construction and stainless steel for components in contact with liquid
- Motor shaft is completely insulated from any contact with pumping liquid
- Phenolic/Ceramic mechanical shaft seal with nitrile elastomers and 18-8SS components
- Standard 2" union connections (ordered separately) ensure easy service and optimum water flow
- Three-way volute discharge port rotates at 90° increments without removing motor
- Lightweight design



ORDERING INFORMATION

Model	HP	Dis. x Suc. (MBPT)	Voltage	S.F.A.	Order No.	Wt. (lbs)
S2A	2	2" x 2"	115/230	16/8	94216151	27
S3A	3		230	10	94216191	29
S4A	4		230	10	94216301	35
Fittings kit contains (2) 2" slip x threaded connection union halves					31150109	2

NOTE: Set of union halves must be purchased separately.

DIMENSIONS

Model	HP	A	D	E
S2A	2	15.19"	3.38"	7.94"
S3A	3	16.44"	3.38"	8.06"
S4A	4	16.81"	3.50"	8.06"

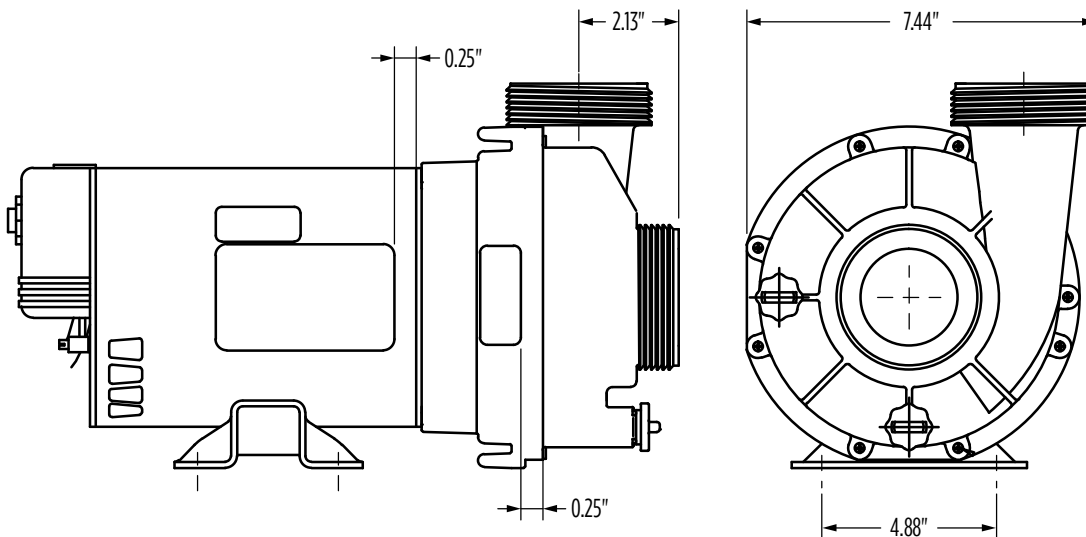



MENU

NON-CORROSIVE TRANSFER PUMPS - A SERIES

PERFORMANCE

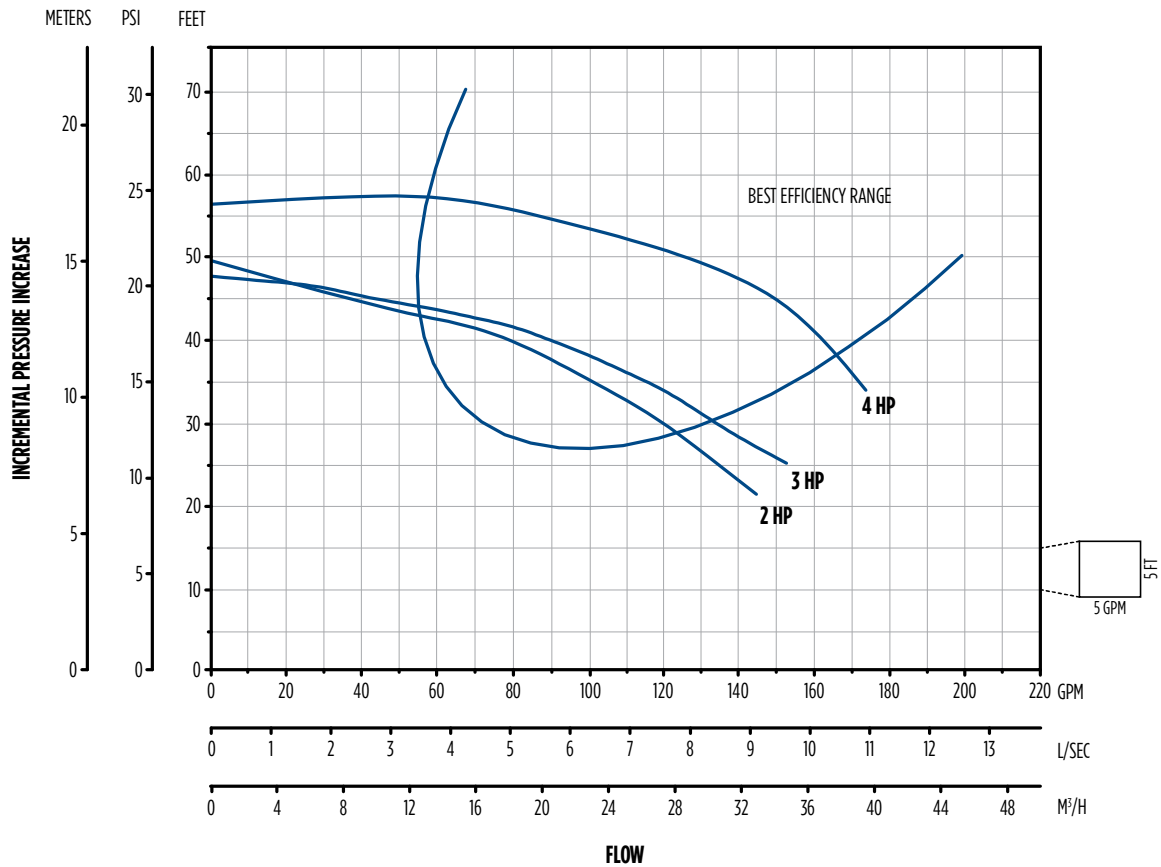

Model	HP	Total Head (ft)					Shut-off Head (ft)
		20	30	40	50	60	
S2A	2	148.0	119.0	78.0	-	-	49
S3A	3	172.0	132.0	89.0	-	-	47
S4A	4	-	180.0	162.0	120.0	-	56