

MonoDrive UTILITY

MONODRIVE UTILITY

NEMA 3R ENCLOSURE



MONODRIVE UTILITY

Franklin Electric's MonoDrive Utility™ Variable Frequency Drive provides an easy-to-install 3-wire constant pressure solution for 230 V submersible pumping systems up to 2 hp. Requiring only a small pressure tank, it offers a more compact overall footprint compared to traditional water systems, while providing the added value of constant water pressure and built-in motor protection. One MonoDrive Utility replaces up to nine control box configurations, simplifying inventory requirements while providing a more desirable value for the end user.

FEATURES & BENEFITS

- Compatible with Franklin Electric submersible 3-wire motors
- Provides constant pressure and motor/pump protection in a small and robust package
- Easily replaces the control box in conventional 230 V single-phase, 3-wire submersible systems
- User-defined underload protection, and several pressure control adjustments, to fit a wide range of pumping applications
- Robust pressure sensor standard for ease of installation
- Additional input for optional analog pressure transducer for precise pressure control
- No programming required with easy DIP switch setup
- Three LED indicators allow for easy identification of system status and troubleshooting
- USB port allows for easy firmware updates and fault history downloads
- UL and cUL listed



ORDERING INFORMATION: SUBMERSIBLE APPLICATIONS

Drive Model	Order No.	230 V Single-Phase 3-Wire				
		1/2 HP	3/4 HP	1 HP	1.5 HP	2 HP
MonoDrive Utility UT3W	5870202203	✓	✓	✓	✓	✓

NOTE: Not equipped with FE Connect mobile app

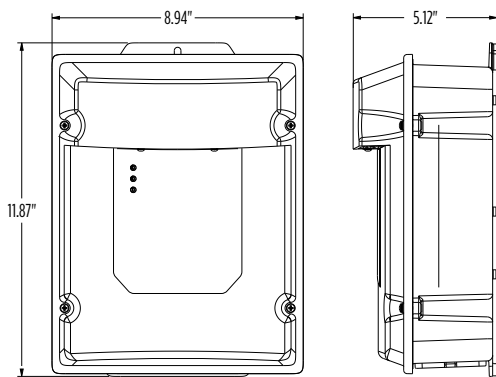

MonoDrive Utility™

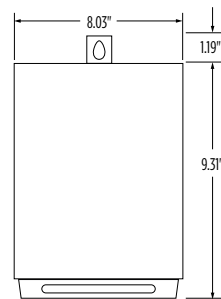

Standard/Deluxe Control Box*

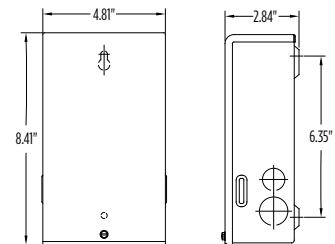

Quick Disconnect Control Box*

* Not included with a MonoDrive Utility. Dimensions are for reference only.