

SubDrive

Tank Drawdown Installation
Instruction Manual 225770901



Franklin Electric



Franklin Electric

400 E. Spring Street Bluffton, IN 46714
Tel: 260-824-2900 • Fax: 260-824-2909
www.franklin-electric.com

225767101 Rev. 2
M1617 10-10

TANK DRAWDOWN INSTALLATION INSTRUCTION MANUAL

Contents

SubDrive NEMA 4	2-5
SubDrive300	6-10

Purpose

The tank drawdown kit uses the system run relay and an additional pressure sensor to allow the use of water stored in the tank during low flow demands.

This setup will allow the drive to control pressure using the regulating sensor to maintain constant pressure when operating normally. Once the system shuts off, it will use the stored water in the tank until the pressure drops to the secondary sensor pressure setting. At that time, the drive will start and regulate to the regulating pressure sensor pressure setting.

Tools and Hardware Required

A Philips screwdriver is required to remove the SubDrive access panel. A crimp tool may be required for the 1/4" quick connects that will attach the aux device to the relay interface.

For the SubDrive Nema 4 units, excluding the SubDrive300, an Auxiliary Relay Board is required. An Auxiliary Relay Board kit can be purchased with order number 225755901.

▲ WARNING

Serious or fatal electric shock may result from failure to remove electrical power from the SubDrive prior to installing the relay interface. Disconnect power before working on the system. Capacitors inside the SubDrive can still hold a lethal voltage for some time after power has been removed, so allow 10 minutes after removing supply power for dangerous internal voltage to discharge.

ATTENTION

This equipment is intended for installation only by technically qualified personnel. Failure to install it in compliance with national and local electrical codes and within Franklin Electric's recommendations may result in electrical shock or fire hazard, unsatisfactory performance, and equipment failure.



TANK DRAWDOWN INSTALLATION INSTRUCTION MANUAL

SubDrive Nema 4 Installation Procedure (For SubDrive300 see pg 6)

1. If the SubDrive is powered, remove power from the drive and wait at least 10 minutes before accessing the drive to ensure that the bus voltage has been given sufficient time to dissipate.
2. Remove the customer access panel.

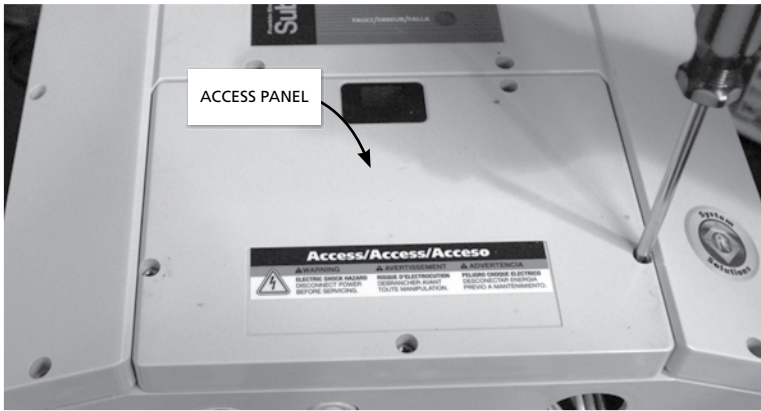

3. Verify Auxiliary Relay Board is installed. If not, please refer to the Auxiliary Relay Board Instruction Manual M1604 and follow instructions.

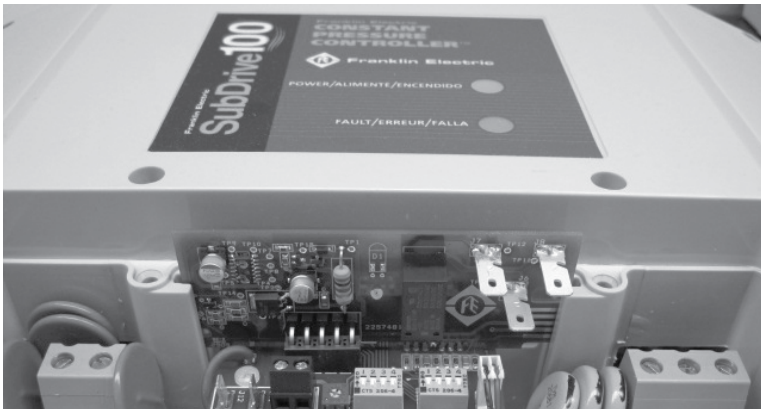

TANK DRAWDOWN INSTALLATION INSTRUCTION MANUAL

4. Add a second 25 to 80 psi sensor to the system. The pressure setting on the additional sensor will need to be set below the regulating sensor, but above the tank pre-charge pressure. The pressure can be adjusted once the system is up and running.



5. Use the supplied 6 conductor pressure sensor cable to attach the sensor cable to the sensor as shown. (See Figure 1, pg 5, for Wiring)

6. Bring the sensor cable into the drive via the knockout at the bottom. (Be sure to follow local codes requiring conduit or sealing practices. In order to maintain a NEMA 4 rating, a connector must be used.)

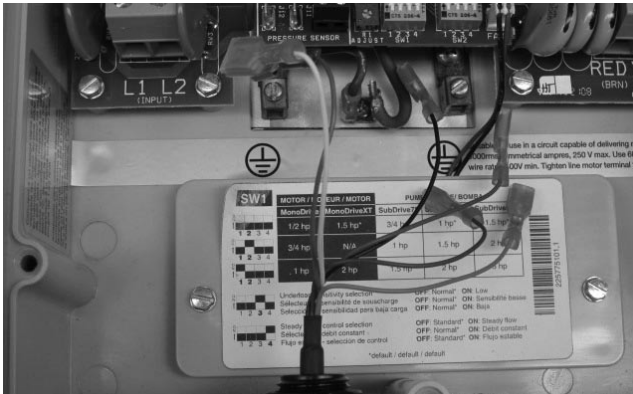

TANK DRAWDOWN INSTALLATION INSTRUCTION MANUAL

7. Connect the green wire to the pressure sensor (J11) terminal at the SubDrive. Connect the white wire to the piggyback connector at J11.

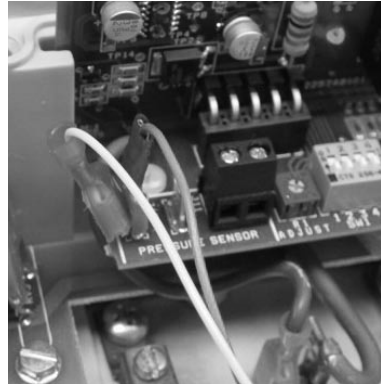
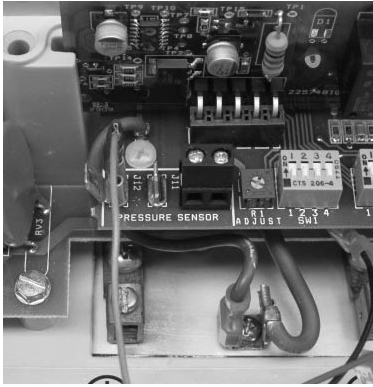

8. Connect the Jumper wire to the pressure sensor (J11) terminal and to the Common (COM) terminal of the Auxiliary Relay Board.

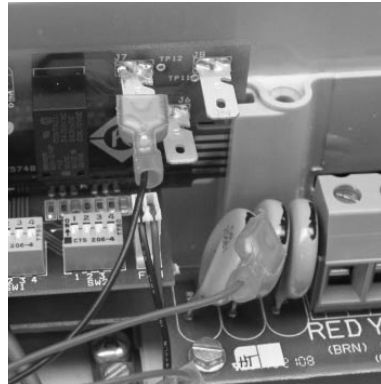
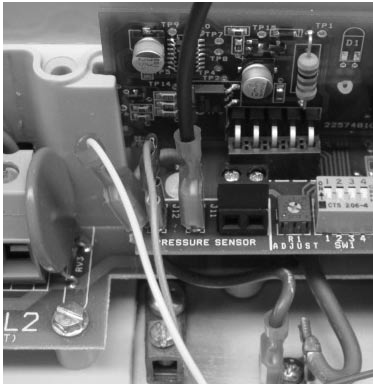

9. Connect the black wire from the cut-in pressure switch to the Normally Closed (NC) terminal on the Auxiliary Relay Board. Connect the Red wire from the regulating pressure switch to the Normally Open (NO) terminal on the Auxiliary Relay Board.

TANK DRAWDOWN INSTALLATION INSTRUCTION MANUAL

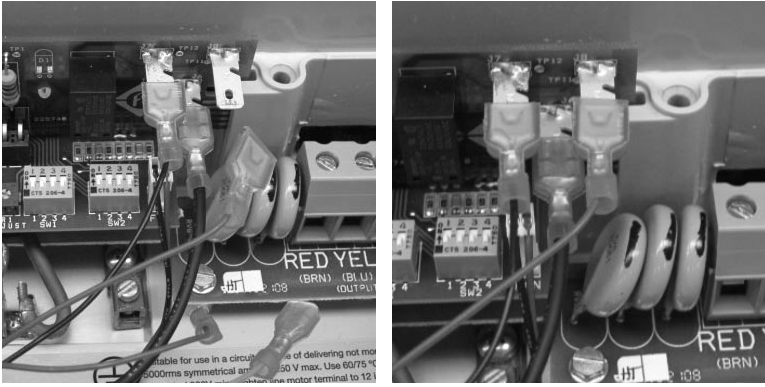

10. The orange and blue wires are not used. Remove terminals and use electrical tape to insulate.
11. Re-attach the customer access cover.
12. Re-apply power to the drive.
13. Adjust the pressure setting of the low pressure cut-in switch for the appropriate off time. The pressure setting on the additional sensor will need to be set below the regulating sensor, but above the tank pre-charge pressure.

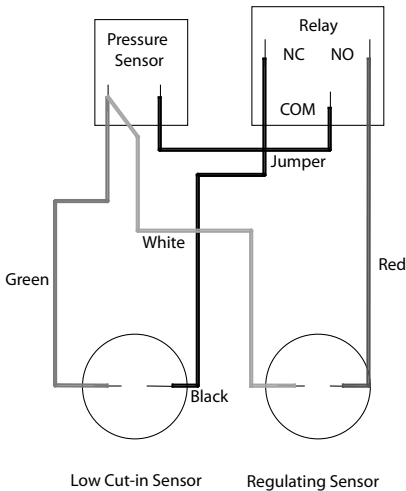

Figure 1: SubDrive NEMA 4 Wiring

SubDrive300 Installation Procedures

1. If the SubDrive is powered, remove power from the drive and wait at least 10 minutes before accessing the drive to ensure that the bus voltage has been given sufficient time to dissipate.
2. Add a second 25 to 80 psi sensor to the system. The pressure setting on the additional sensor will need to be set below the regulating sensor, but above the tank pre-charge pressure. The pressure can be adjusted once the system is up and running.



- 3.) Remove the outside cover.
- 4.) Use the supplied 6 conductor pressure sensor cable to attach the sensor cable to the sensor. (See Figure 2, pg 10, for Wiring.)
- 5.) Bring the sensor cable into the drive via the knockout at the bottom. (Be sure to follow local codes requiring conduit or sealing practices. In order to maintain a NEMA 4 rating, a connector must be used.)

TANK DRAWDOWN INSTALLATION INSTRUCTION MANUAL

6. Connect the green wire to the pressure sensor (J12) terminal at the SubDrive. Connect the white wire to the piggyback connector at J12.

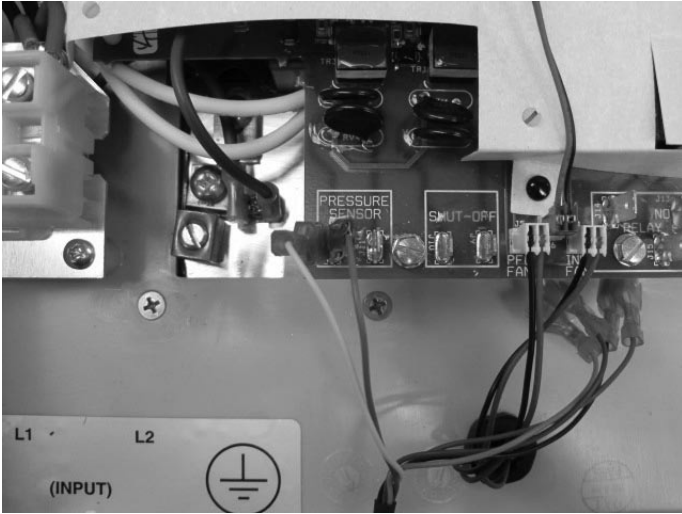

7. Connect the Jumper wire to the pressure sensor (J11) terminal and to the Common (COM) terminal.

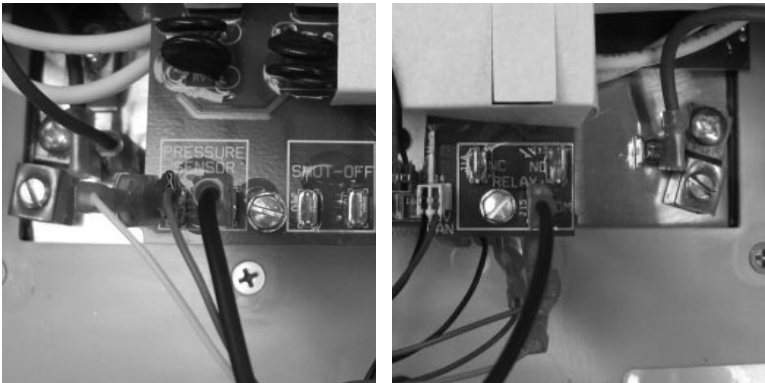

TANK DRAWDOWN INSTALLATION INSTRUCTION MANUAL

8. Connect the black wire from the cut-in pressure switch to the Normally Closed (NC) terminal on the Auxiliary Relay Board. Connect the Red wire from the regulating pressure switch to the Normally Open (NO) terminal on the Auxiliary Relay Board.

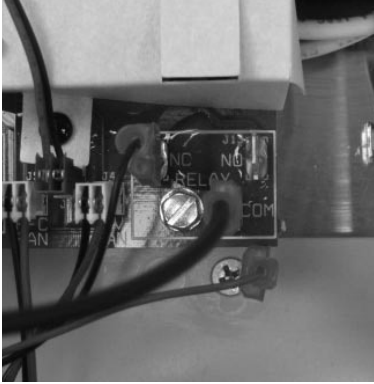

9. Connect the orange and blue wires to the shut-off terminals.

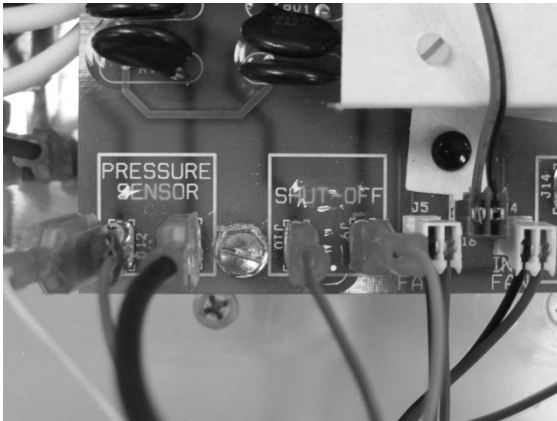

TANK DRAWDOWN INSTALLATION INSTRUCTION MANUAL

10. Re-attach the access cover.



11. Re-apply power.

12. Adjust the pressure setting on the low pressure cut-in switch for the appropriate off time. The pressure setting on the additional sensor will need to be set below the regulating sensor, but above the tank pre-charge pressure.

TANK DRAWDOWN INSTALLATION INSTRUCTION MANUAL

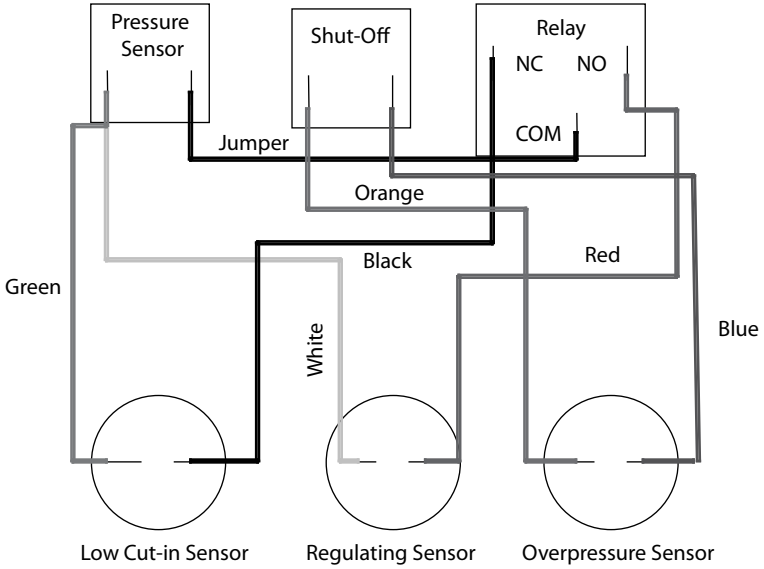

Figure 2: SubDrive300 Wiring

**TANK DRAWDOWN
INSTALLATION INSTRUCTION MANUAL**

Notes:

**TANK DRAWDOWN
INSTALLATION INSTRUCTION MANUAL**

Notes: