



HYDROMATIC®

A+

Battery Backup Power Supply

For use with Hydromatic model B-A1/BV-A1

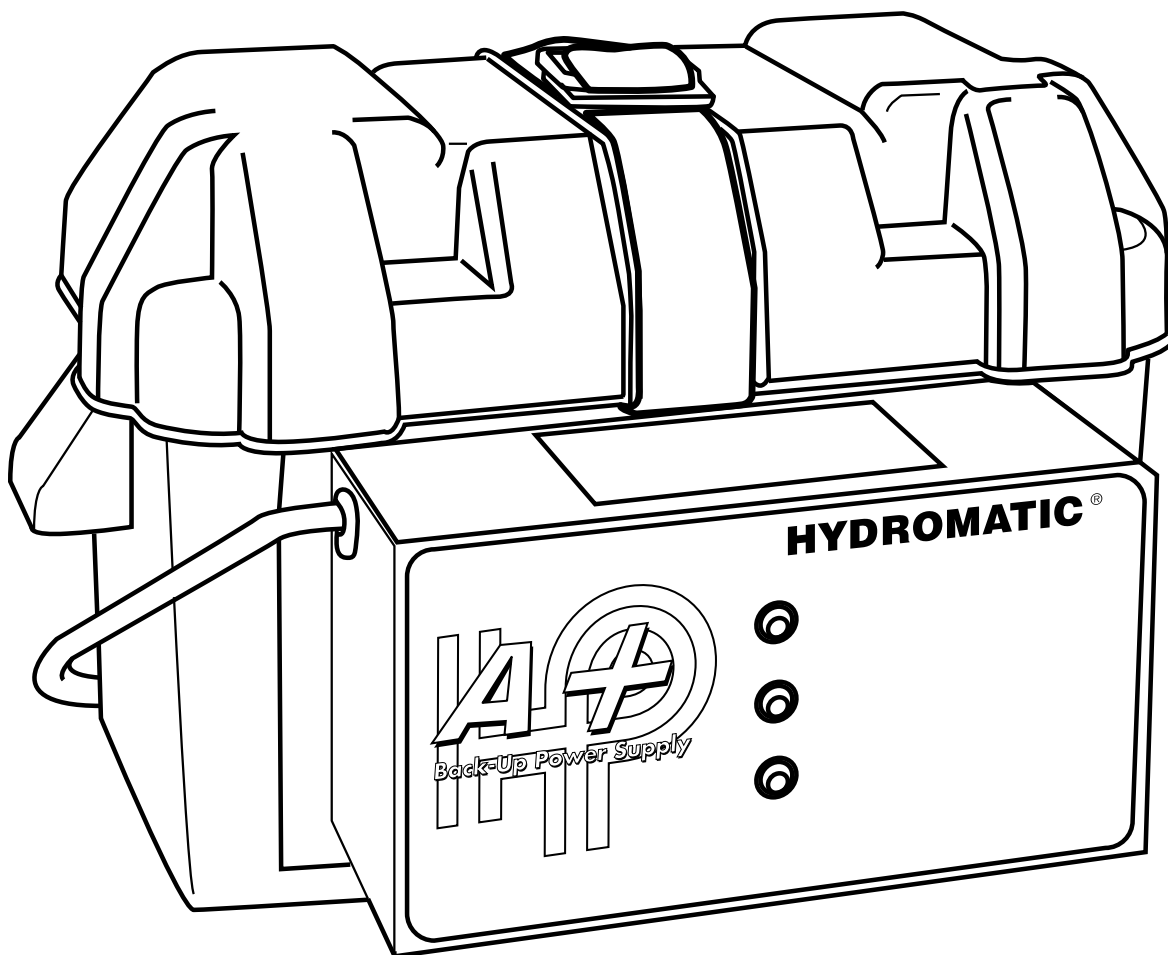

NOTE! To the installer: Please make sure you provide this manual to the owner of the pumping equipment or to the responsible party who maintains the system.



**Pentair
Water™**

General Information

Thank you for purchasing your Hydromatic® product. To help ensure years of trouble-free operation, please read the following manual carefully.

Before Operation:

Reasonable care and safe methods should be practiced. Check local codes and requirements before installation. This manual contains important information for the safe use of this product. Read this manual completely before using this product and refer to it often for continued safe product use. **DO NOT THROW AWAY OR LOSE THIS MANUAL.** Keep it in a safe place so that you may refer to it when needed.

Warning:

Always disconnect the Unit from the receptacle power source and battery before handling or making any adjustments to the system.

Battery Backup Warning

- 1. Risk of electrical shock:** This unit has not been investigated for use in outdoor areas.
- 2. Risk of electrical shock:** Connect only to a properly grounded, three pronged grounding type receptacle. Under any circumstances do not remove the grounding prong from the power cord.

Do not smoke, use sparkable electrical devices or open flame when working on this Unit!

4. Do not install Unit in locations classified as hazardous per N.E.C., ANSI/NFPA 70 - 1999.

Failure to heed above cautions could result in injury or death.

Attention:

The A+ Battery Backup System is to be used only with the Hydromatic pump supplied with the Unit. Using anything other than the pump supplied with the system will cause damage to the Unit and void the warranty.

Tools Needed:

A pipe wrench, pliers, adjustable wrench, and screwdriver will be needed.

Battery Requirements:

Your Unit operates on 12V DC battery power when in the power fail mode; a UL recognized deep cycle marine battery should be used.

We recommend:

**Crown Battery
Model # 27T-36
Factory Tel: 419-334-7181**

Installation Instructions

For submersible sump pump installation instructions, please use the installation manual for the Hydromatic B-A1, Item # W-03-410.

1. Open the lid on the battery enclosure and place the lower half of the battery enclosure with the Unit in a suitable place where a 120V three prong outlet is within reach of the receptacle power cord, and where water will not drip or splash on the Unit. It is also important to make sure that the fan inlets on each side of the battery backup enclosure are free from obstructions. It is also recommended that the Unit be placed on a board or cinder block to keep it off the moist floor and free from debris.
2. After the battery box has been put in a suitable location, the battery can be installed.

Battery Installation

A battery can present a risk of severe burns and injury from high short circuit current. The following precautions should be observed when working on batteries.

1. Remove watches, rings, or other metal objects.
2. Use tools with insulated handles.
3. Do not lay tools or metal parts on top of batteries.

Installation Instructions

After taking the above precautions, lower the 12V battery into the enclosure with the terminals facing the front of the Unit where the indicator lights and battery cables are located. At this time check the polarity of your marine battery. Facing the front of the Unit, the left battery terminal should be positive and the right, negative. If this is not the case do not continue until the proper battery can be obtained. (Do not try to correct this problem in any other way than by using the proper battery.)

Now that the battery has been installed with the terminals nearest to the red and black wires, **PLUG THE UNIT INTO A 120V OUTLET BEFORE CONNECTING THE BATTERY LEADS.** With the Unit plugged into the 120V outlet connect the battery leads to the marine battery making sure the red wire is connected to the positive terminal and black wire is connected to the negative terminal. Make sure all battery connections are properly tightened to 75 inch pounds. Then place the battery box cover back on the Unit and strap it down so that children cannot tamper with the Unit. At this time you may plug the high efficiency pump supplied with the System into the back of the piggyback plug on the Unit.

DO NOT PLUG ANY OTHER PUMP THAN THE PUMP SUPPLIED WITH THE UNIT INTO THE UNIT. DOING SO WILL VOID THE WARRANTY!

Functions and Lights:

1. With the pump plugged into the power cord receptacle, the power cord plugged into a building receptacle:
 - A. Power loss (inverter on) light OFF
 - B. Battery charging light ON
 - C. Fully charged light ON

2. With the pump plugged into the power cord receptacle, the power cord plugged into a building receptacle, battery installed and connected, RECEPTACLE POWER ON:
 - A. Power loss (inverter on) light OFF
 - B. Battery charging light ON
 - C. Fully charged light OFF
 - D. (If fully charged, light) (ON)

3. With the pump plugged into the power cord receptacle, the power cord plugged into a building receptacle, battery installed and connected, RECEPTACLE POWER OFF:
 - A. Power loss (inverter on) light ON
 - B. Battery charging light OFF
 - C. Fully charged light OFF
 - D. (If fully charged, light) (ON)

4. AFTER EACH 5 MINUTES OF OPERATION, the Unit halts inverter operation for 5 seconds to test for receptacle power, pump stops:
 - A. Power loss (inverter on) light OFF
(may slowly dim)
 - B. Battery charging light OFF
 - C. Fully charged light OFF
 - D. If receptacle power is found to be present,
see # 2 above.
 - E. If receptacle power is found to be off,
see # 3 above.

5. If battery voltage falls below a usable charge, PUMP WILL STOP:
 - A. Power loss (inverter on) light OFF
 - B. Battery charging light FLASH
 - C. Fully charged light OFF

6. Battery voltage may recover and allow brief periods of operation.

Note:

Charging the battery in this Unit should not take longer than 36 hours.

Testing:

To test the Unit simply unplug it from the receptacle and add water to sump until pump pumps sump down. Run the pump supplied with the Battery Backup System for only a few cycles. You can repeat this if you wish, but it is not necessary. If the Unit works the first time it is sure to work time and time again. Be sure that you remember to plug the Unit back into the receptacle after you have completed the test. NOTE: If while testing the Unit the pump does not turn on, the following steps should be taken:

1. Check the charger and inverter lights to see if they are on.
2. Check the circuit breaker.
3. Plug the pump you have plugged into the Unit directly into a live building receptacle. If the pump runs, recheck all the battery connections and battery voltage.
4. Check sump water level to see that pump is being required to run.
5. If the above items have been thoroughly checked and your pump will still not run when plugged into the Unit, remove the battery from the battery box as described in the assembly instructions and return the Unit to the place of purchase for repair or replacement.

Battery Maintenance

1. Servicing of batteries should be performed or supervised by personnel knowledgeable of batteries and the required precautions.
Keep unauthorized personnel away from batteries.
2. When replacing the battery, use the same type of battery (see battery requirements for ordering information).
3. **CAUTION:** Do not dispose of battery in a fire. The battery may explode.
4. **CAUTION:** Do not open or mutilate the battery. Released electrolyte is harmful to the skin and eyes. It may be toxic.
5. **CAUTION:** A battery can present a risk of severe burn and injury from high short circuit current. The following precautions should be observed when working on batteries.
6. Remove watches, rings, or other metal objects.
7. Use tools with insulated handles.
8. Do not lay tools or metal objects on top of batteries.
9. **CAUTION:** The electrolyte is a dilute sulfuric acid that is harmful to the skin and eyes. It is electrically conductive and corrosive. The following procedures should be observed:
 - a. Wear full eye protection and clothing.
 - b. If electrolyte contacts the skin, wash it off immediately.
 - c. If electrolyte contacts the eyes, flush thoroughly and

immediately with water. Seek medical attention.

d. Spilled electrolyte should be washed down with a suitable acid neutralizing agent. A common practice is to use a solution of approximately one pound (500 grams) bicarbonate of soda to approximately one gallon (4 liters) of water. The bicarbonate of soda solution should be added until the evidence of reaction (foaming) has ceased. The resulting liquid should be flushed with water and the area dried.

e. **CAUTION:** Lead acid batteries can present a risk of fire because they generate hydrogen gas. The following procedures should be followed:

f. **DO NOT SMOKE** when near batteries.

g. **DO NOT** cause flame or spark in battery area.

h. Discharge static electricity from body before touching batteries by first touching a grounded metal surface.

11. See battery manufacturer's installation manual for additional battery installation and maintenance instructions.

Your Unit has been designed to be virtually maintenance free. Just make sure it is kept clean and dry and that the Unit is periodically tested.

Warranty Is Void, If...

1. Power cord has been cut or the grounding prong has been removed.
2. Unit has been used in an outdoor application.
3. Batteries not meeting the above specifications have been used.
4. Unit has been submerged in water.
5. Unit has been tampered with in any manner not described in the above instructions.
6. Unit has been disassembled by customer.
7. Unit has been applied to products exceeding the maximum capacity of the Unit.
8. Unit has been applied to the wrong voltage.
9. The A+ Battery Backup System is used with any other pump than the Hydromatic B-A1 pump.

A+ Battery Backup performance with a Hydromatic B-A1 Pump

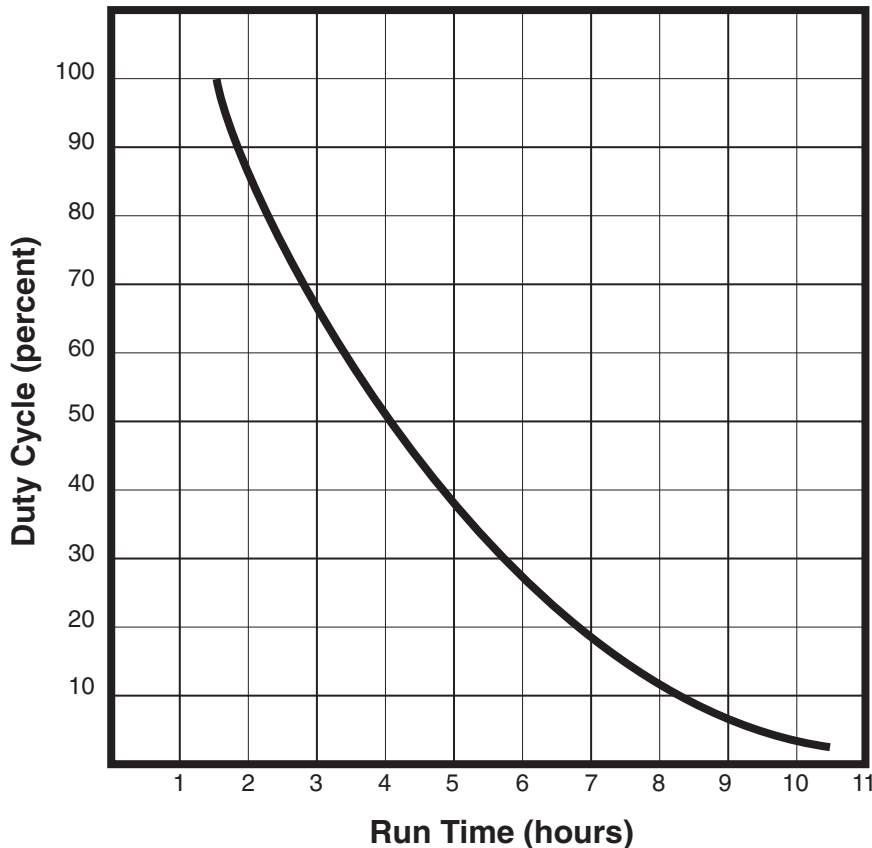

Test results are based on the following criteria:

Pump Current Draw: 5.8 Amps

Specific gravity of battery fluid at the start of each test: 1300

Start: 13.45 Volts

Finish: 10.2 Volts

LIMITED WARRANTY

HYDROMATIC warrants to the original consumer purchaser ("Purchaser" or "You") of HYDROMATIC Sump Pumps, Effluent Pumps, Sewage Pumps (other than 2-1/2"), and Package Systems, that they will be free from defects in material and workmanship for the Warranty Period of 36 months from date of manufacture.

Our warranty will not apply to any product that, in our sole judgement, has been subject to negligence, misapplication, improper installation, or improper maintenance. Without limiting the foregoing, operating a three phase motor with single phase power through a phase converter will void the warranty. Note also that three phase motors must be protected by three-leg, ambient compensated, extra-quick trip overload relays of the recommended size or the warranty is void.

Your only remedy, and HYDROMATIC's only duty, is that HYDROMATIC repair or replace defective products (at HYDROMATIC's choice). You must pay all labor and shipping charges associated with this warranty and must request warranty service through the installing dealer as soon as a problem is discovered. No request for service will be accepted if received after the Warranty Period has expired. This warranty is not transferable.

EXCEPTIONS: Hydromatic Special Application Pumps, Battery Back-Up Sump Pumps, Filtered Effluent Pumps, Grinder Pumps, and 2-1/2" Sewage Pumps are warranted for a period of 12 months from date of purchase or 18 months from date of manufacture, whichever comes first.

HYDROMATIC SHALL NOT BE LIABLE FOR ANY CONSEQUENTIAL, INCIDENTAL, OR CONTINGENT DAMAGES WHATSOEVER.

THE FOREGOING WARRANTIES ARE EXCLUSIVE AND IN LIEU OF ALL OTHER EXPRESS AND IMPLIED WARRANTIES, INCLUDING BUT NOT LIMITED TO THE IMPLIED WARRANTIES OF MERCHANTABILITY AND FITNESS FOR A PARTICULAR PURPOSE. THE FOREGOING WARRANTIES SHALL NOT EXTEND BEYOND THE DURATION EXPRESSLY PROVIDED HEREIN.

Some states do not allow the exclusion or limitation of incidental or consequential damages or limitations on the duration of an implied warranty, so the above limitations or exclusions may not apply to You. This warranty gives You specific legal rights and You may also have other rights which vary from state to state.

This warranty supersedes and replaces all previous warranty publications.

HYDROMATIC

740 East 9th Street, Ashland, OH 44805

Phone: 888-957-8677 • Fax: 888-840-7867 • Web Site: <http://www.hydromatic.com>

– Your Authorized Local Distributor –



HYDROMATIC®

Pentair Water

USA

740 East 9th Street, Ashland, Ohio 44805

Tel: 888-957-8677 Fax: 888-840-7867

www.hydromatic.com

CANADA

269 Trillium Drive, Kitchener, Ontario, Canada N2G 4W5

Tel: 519-896-2163 Fax: 519-896-6337