

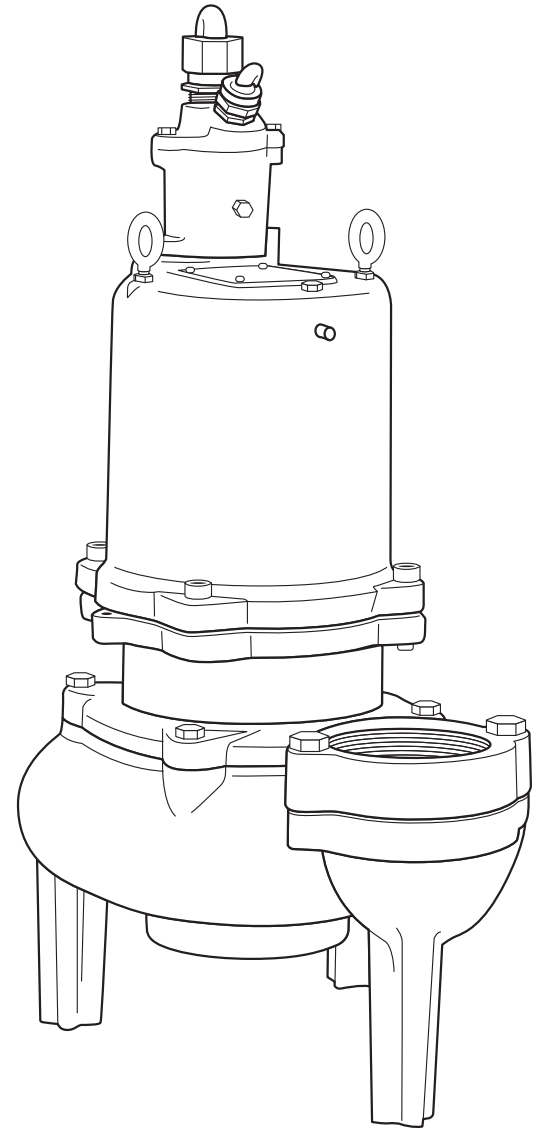

HYDROMATIC®



MODELS
S3H(X*), S4H(X*),
S3N(X*) and S4N(X*)

*Used in Hazardous Locations Class I, Division 1

SUBMERSIBLE SOLIDS HANDLING PUMP

INSTALLATION AND SERVICE MANUAL

NOTE! To the installer: Please make sure you provide this manual to the owner of the equipment or to the responsible party who maintains the system.

(*Hazardous Location
Motor End)



General Information

Before Installation:

This manual contains important information for the safe use of this product. Read this manual completely and follow the instructions carefully. Reasonable care and safe methods relating to the installation and operation of this product should be practiced. Check local codes and requirements before installation.

Safety Warnings

DANGER: Risk of electrical shock or electrocution. May result in serious injury or death or fire hazard. Installer must disconnect all electrical sources prior to installation, handling or servicing. Only qualified personnel may install this system. NFPA 70/National Electric Code (NEC) or local codes must be followed. System must be properly grounded according to NEC. Do not lift pump by power cord.

DANGER: Biohazard risk. Once wastewater source has been connected to system, biohazard risk exists. Installer(s) and/or service personnel must use proper personal protective equipment and follow handling procedures per OSHA 29 CFR 1910.1030 when handling equipment after wastewater source has been connected to system.

DANGER: Risk of asphyxiation. Installer(s) and/or service personnel must use proper personal protective equipment and follow OSHA 29 CFR 1910.146 or OSHA 29 CFR 1926. Pump may be installed in a location classified as a confined space.

DANGER: Cutting risk. Risk of serious cutting or amputation exists. Disconnect all power sources prior to servicing the pump. Pump may start without warning.

Pumps are not approved for use in swimming pools, recreational water installations, decorative fountains or any installation where human contact with the pumped fluid is common.

CALIFORNIA PROPOSITION 65 WARNING:

▲ WARNING This product and related accessories contain chemicals known to the State of California to cause cancer, birth defects or other reproductive harm.

The Pump

Shipping:

When unpacking unit check for concealed damage. Claim for damage must be made at the receiving end through the delivering carrier. Damage cannot be processed from the factory.

Pumps in Storage or Not Operating:

Pumps with carbon ceramic seals must have impellers manually rotated (6 revolutions) after setting non-operational for 3 months or longer and prior to electrical start-up.

Pumps with tungsten carbide seals must have impellers manually rotated (6 revolutions) after setting non-operational for 3 weeks or longer and prior to electrical start-up.

Seal Failure:

An electrode is installed in the seal chamber so if any water enters the chamber through the first seal the electrode will be energized, and a signal will be transmitted to the sensing unit at ground surface, causing an alarm function to energize.

In operation the seal failure unit indicates only that there is some water in the seal chamber. The pump will continue to operate without damage but the seal should be checked immediately after failure is indicated.

NOTE: Failure to install such a device negates all warranties by Hydromatic®.

Seal Failure Probes:

All hazardous location submersible pumps have two factory installed moisture detectors (seal failure probes). They are in a normally open series circuit in the seal chamber. Under normal operating conditions, the circuit remains open. If the lower seal leaks and moisture enters this

chamber, the moisture would settle to the bottom of the chamber and will complete the circuit between the moisture detectors.

This circuit must be connected to a sensing unit and signaling device. This is supplied in a Hydromatic built control panel.

Pump:

The submersible pump is supplied for 1 and 3 phase, and for 200, 230, 460 or 575 volts. A power cable is supplied with the green wire for ground. Be sure green wire is connected to a good ground such as water pipe or ground stake.

Heat Sensors:

All motors have heat sensor units embedded in the motor winding to detect excessive heat. The sensors automatically reset when motor cools to safe temperature.

The sensors are connected in series with the motor starter coil so that the starter is tripped if heat sensor opens. The motor starter is equipped with overload heaters so all normal overloads are protected by the starter.

NOTE: Failure to install such a device negates all warranties by Hydromatic.

Once sensor resets, the starter is to be reset for FM for continued operation of the pump. This circuitry is supplied in a Hydromatic control panel.

NOTE: Failure to install such circuitry would negate FM approvals and all warranties by Hydromatic.

Sump Level Control:

The sump level is controlled by Hydromatic float switch controls. The float is held in position in the sump by a weight attached to the power cord above the float. The cord supports the float and is adjusted for height from the surface.

Typical duplex systems use three controls: one set at turn-off, one set at turn-on for one pump, and one set for turn-on for two pumps. Pumps alternate operation on each successive cycle.

Two pumps operate together only if sump level rises to the third or

override control. The override control also brings on the second pump in case of failure of the first pump. Extra floats with appropriate controls can be supplied for alarm functions. Triplex systems use four controls: one set at turn-off, one set at turn-on for one pump, one set at turn-on for two pumps, and one set at turn-on for three pumps. Pumps alternate each successive cycle.

Three pumps operate together only if sump level rises to the fourth control (second override). This control also brings on the third pump in case of failure of either or both of the first two pumps.

Alarm Controls:

The alarm level is usually set above the override level so the alarm will signal only if the override level is exceeded. However, some engineers prefer to have the alarm level set below the override level as it is possible for one pump to fail and the other pump to operate on the override level with the sump level never reaching the alarm level. This is particularly true in cases of low inflow capacity.

Electrical Control Panel:

It is recommended that the Hydromatic control panel be used with all pumps, as proper starter heaters, and connections for heat sensor wires are furnished.

IMPORTANT: If Hydromatic electrical controls are not used and the motor fails because of improper components or if the heat sensors are not properly connected, the warranty is void.

Hydromatic electrical equipment is installed in a weatherproof NEMA 3R enclosure. The electrical equipment includes a main circuit breaker for each pump, a magnetic starter with overload protection for each pump, an H-O-A switch and run light for each pump, an electric alternator and a transformer to provide appropriate control for control circuit and alarms.

Power Cords:

The power cord and heat sensor seal failure cord are potted into the connection box cap. The cords must not be spliced.

Overload Heaters:

If the Hydromatic electrical panel is not used, starters with 3-leg overload protection must be supplied. On 3 phase pumps the heaters must be sized in accordance with the nameplate amps on the motor housing. The amp draw on these submersible motors is slightly higher than a corresponding horsepower surface motor, so heaters must be sized by the nameplate rating.

Single phase pumps with capacitor start have a run and a start winding; each drawing a different current. To adequately protect these windings with the appropriate heaters, consult the factory.

NOTE: Red lead is always start winding of pump using single phase.

Installation Instructions

Installing Sump Level Control Float Controls:

In either simplex, duplex or triplex systems the lower or turn-off control is to be set to maintain a minimum level in the sump. This level shall be no more than 3¼" from the top of the motor housing down to the surface of the sewage.

The second or turn-on control is set above the lower turn-off control. The exact distance between the two floats must be a compromise between a frequent pumping cycle (10 starts per hour max.) to control septicity, solids and a slower cycle for energy economy. This distance should be determined by the engineer or consulting engineer, depending on the conditions of the application.

Installing Pump in Sump:

Before installing pump in sump, lay it on its side and turn impeller manually. Impeller may be slightly stuck due to factory test water, so it must be broken loose with small bar or screwdriver in edge of vanes. The impeller should turn freely.

Clean all trash and sticks from sump and connect pump to piping.

A check valve must be installed on each pump. A gate or plug valve in each pump discharge line is also recommended. This valve should be

installed on the discharge side of the check valve, so if necessary to service the check valve, the line pressure can be cut off. Single pump systems are sometimes installed without a check valve, where it is desirable to self-drain the discharge line to prevent freezing. This can be done only with short discharge lines, otherwise water will return to the sump and cause short cycling of the pump.

NEMA 4 Junction Box: (Optional)

If electrical control panel is to be set remote from the pump sump, a NEMA 4 junction box should be used to make power and control connections. The Hydromatic NEMA 4 junction box is provided with compression connectors for sealing all wires. No sealing compound is needed to make connections waterproof.

The size wire to use from panel to sump depends on motor size and distance in feet.

Be sure each wire is checked out so that a wrong connection will not be made. An ohmmeter or Megger can be used to check wire continuity.

Installing Float Switch Controls:

The controls are supported by a mounting bracket that is attached to sump wall or cover, or to the NEMA 4 junction box.

Cord snubbers are used to hold the cord in place. Control lever can be changed at any time by loosening the snubber and readjusting cord length.

In either simplex or duplex system the lower or turn-off control is set just above the top of volute so that the volute will always be submerged during the pumping cycle. The second, or turn-on control, is set about 24 inches above the lower turn-off control.

More distance between turn-on and turn-off controls can be used, but sewage may become septic and excessive solids may collect for the pump to handle. A frequent pumping cycle is recommended for best operation.

If an alarm system is used, this control is usually set about 6 inches above the override control. Some engineers, as described previously, prefer to have the alarm control set below the override control.

Making Electrical Connections:

All electrical wiring must be in accordance with local code.

IMPORTANT: If equipment is not properly wired and protected as recommended, the warranty is void.

Heat Sensors and Seal Failure Connections:

Be sure that heat sensor wires are connected in series with the starter coil.

Pump Operation

Starting System

1. Turn H-O-A switch to Off position, then turn on main circuit breakers.
2. Open all discharge valves and allow water to rise in sump pump.
3. Turn H-O-A switch to Hand position on one pump and notice operation. If pump is noisy and vibrates, rotation is wrong. To change rotation, interchange any two line leads to motor on 3Φ.
Do not interchange main incoming lines. If operating duplex system, check second pump in the same manner.
4. Now set both H-O-A switches to Auto position and allow water to rise in sump until one pump starts. Allow pump to operate until level drops to turn-off point.
5. Allow sump level to rise to start other pump. Notice run lights on panel; pumps should alternate on each successive cycle of operation.
6. Turn both H-O-A switches to Off position and allow sump to fill to the override control level.
7. Turn both switches to Auto position and both pumps should start and operate together until level drops to turn-off point.
8. Repeat this operation cycle several times before leaving the job.
9. Check voltage when pumps are operating and check the amp draw of each pump. Check amps on each wire as sometimes a high leg will exist. One leg can

be somewhat higher, 5% to 10%, without causing trouble. For excessive amp draw on one leg, the power company should be consulted.

Pump Service

As the motors are oil filled, no lubrication or other maintenance is required.

If the pump is used on a Hydrorail system, it should be lifted once every six months and checked for corrosion and wear.

WARNING: Before handling these pumps and controls, always disconnect the power first. Do not smoke or use sparkable electrical devices or flames in a septic (gaseous) or possible septic sump.

Field Service on Motor:

All submersible motors out of warranty can be serviced in the field by any reliable motor service shop. Any pump (in warranty) must be returned to the factory for service or repaired at an authorized Hydromatic service center. Charges will not be allowed if (in warranty) pump is not taken to an authorized Hydromatic service center.

When field service is performed on a pump, these instructions should be carefully followed.

Field Service on Hydromatic Hazardous Location Pumps:

If a Hydromatic hazardous location pump is used in a hazardous location, or if the pump is still in warranty, the pump must be returned to the factory for service. Charges will not be allowed if (in warranty) pump is not taken to an authorized Hydromatic service center. This will ensure the integrity of the hazardous location rating of the pump and comply with our warranty requirements.

Disconnecting Pump Cords:

If a Hydromatic hazardous location pump is to be removed from its location, the pump cords may be disconnected at the control panel (on sump mounted control panels) and cord assembly taken with pump.

CAUTION: Do not reconnect power to a cord and cap assembly while removing from pump.

Replacing Cords:

The power cord and heat sensor – seal failure cord is potted into the connection box cap, forming the cord and cap assembly.

If cords require replacement due to damage or cords being too short, cord and cap assembly must be replaced as a complete assembly available from factory.

Replacing Lower Seal, Impeller or Volute:

The wet end components may be repaired or replaced by an authorized Hydromatic service facility without compromising the hazardous location rating to the pump.

NOTE: Any time the seal is disturbed, it must be replaced.

Replacing Stator on Standard Pump:

1. If stator only is damaged, it may not be necessary to completely dismantle pump as stator and housing can be lifted from pump without disturbing seals or bearings.
2. Drain all oil from upper housing, remove from upper housing, remove drain plug in bottom of stator housing and remove plug in top of housing to allow air to enter.
3. After chamber is drained, remove hold-down bolts and lift off. Use care in lifting as the seal failure connecting wire must be disconnected before housing is completely removed.
4. Set assembly on bench and remove connection box. When box is lifted off, connection wires to motor will be exposed. These wires will probably be burned, but each wire is tagged with a metal marker giving a wire number. Cut the wires. If the leads to the connection box are burned, a complete new connection box with new wire must be used. The wires are potted in with sealing compound, therefore, a new unit must be obtained from the factory.

5. The stator is held in the housing with a bolted-in clamp ring.
6. After ring is removed, turn housing upright and bump on hardwood blocks. This should jar the stator loose and allow it to drop out.
7. Thoroughly clean housing before replacing new stator. Replace stator and make all wire connections to connection box before replacing housing on pump. This is important as leads must be tucked behind the windings by using hands up through the rotor core.

IMPORTANT: Use only compression type insulated connectors on the wires. Do not tape leads as oil will deteriorate the tape and cause damage to stator and bearings.

8. Check top bearing. If clean and does not turn rough, bearings can be reused and it is not necessary to completely dismantle pump to change bearings. If bearings are damaged with dirt or heat, they must be replaced.
9. Replace stator housing onto seal chamber and bolt in place. Be sure seal failure wire is connected before housing is assembled. Be sure O-ring seal has been replaced. If O-ring is nicked or cut, replace with new rings. This applies to all O-rings used in assembly.

10. After all leads are reconnected in the connection box, make a high voltage ground test on each wire. The only wire that should show ground is the green power lead and the ground lead in the auxiliary control cable.
11. For safety, complete pump should be air checked under water for leaks. Fill with oil to about 1 inch below plug hole. Use only high grade transformer oil or regular Hydromatic submersible oil in this chamber. Replace plug; use Permatex® on threads. Install air valve in top plug opening of motor housing and charge housing with about 10 psi of air. Be sure air is dry. Do not use air line where water may be trapped in the line. Submerge complete unit under water and check for leaks.
12. Refill motor chamber with oil. Use high grade transformer oil or Hydromatic special submersible oil. Fill chamber until oil covers top of windings. Leave air space in top for expansion. Use Permatex on plug threads.

Replacing Seals and Bearings on Standard Pump:

1. Drain all oil from motor chamber and seal chamber as described.
2. Remove motor housing.
3. Remove bolts that hold seal chamber to pump housing. Use back-off screws to break loose.

With hardwood block, tap end of impeller to loosen from shaft. When free, remove impeller from shaft.

4. Lift rotating assembly (rotor, shaft and impeller) from pump case.
5. Impeller removal – Hold motor and remove bolt and washer from impeller end of shaft. Impeller is threaded to the shaft, so tap face of impeller to free threads. Holding rotor, turn impeller counterclockwise to free thread.
6. Remove lower seal spring and pry out seal.
7. To remove seal housing, take out socket head bolts and using bolts in back of holes, pry plates loose. This will force out lower seal if not already removed.
8. Remove snap ring that holds upper seal. Pull seal if it is free. If not free, it can be forced off when shaft is removed.
9. Remove bolts that hold bearing housing in place. Set assembly in upright position.
10. Use bearing puller to remove bearings. Replace with new bearings. Press only on inner face of bearing when replacing. Pressing on outer face can damage the bearing.

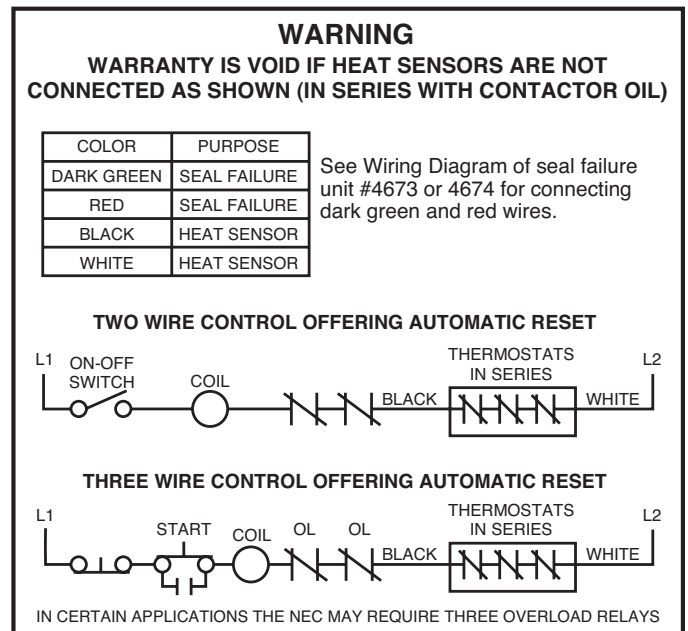
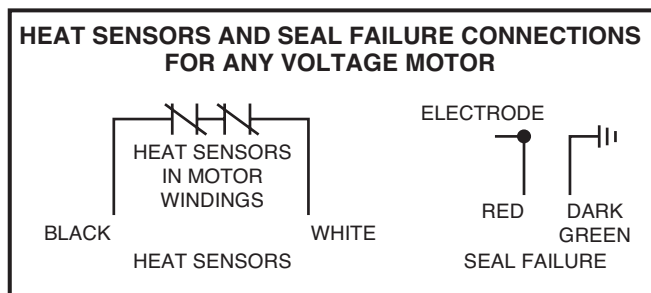
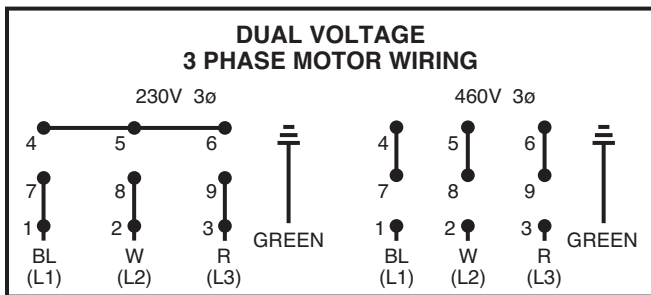

11. Thoroughly clean all castings before replacing seals. One grain of dirt between the seal faces can cause failure.
12. Be sure seal washers are replaced under heads of the 4 bolts that hold bearing cap in place.
13. Be sure key is in place in notch of shaft sleeve to prevent sleeve from turning.
14. Use Locktite® on socket head, locking screw in end of shaft.
15. Before refilling chamber with oil, air test.
16. Refill both chambers with oil.
17. Always check all leads with high voltage or with Megger for grounds before operating the pump.

Pump Troubleshooting

Below is a list of common problems and the probable causes:

Pump will not start.

1. No power to the motor. Check for blown fuse or open circuit breaker.
2. Selector switch may be in the Off position.
3. Control circuit transformer fuse may be blown.
4. Overload heater on starter may be tripped. Push to reset.

Pump will not start and overload heaters trip.

1. Turn off power and check motor leads with Megger or ohmmeter for possible ground.
2. Check resistance of motor windings. All 3 phases should show the same reading.
3. If no grounds exist and the motor windings check OK, remove pump from sump and check for clogged or blocked impeller.

Pump operates with selector switch in Hand position but will not operate in Auto position.

1. This indicates trouble in the float level control or the alternator relay.
2. To check for defective float control, put selector switch in Auto position and turn off main power. Put a jump wire on terminal strip. Turn on power and if pump starts, trouble is in float control. Replace control.

Pump runs but will not shut off.

1. Pump may be air locked. Turn pump off and let set for several minutes, then restart.
2. Lower float control may be hung-up in the closed position. Check in sump to be sure control is free.
3. Selector switch may be in the Hand position.

Pump does not deliver proper capacity.

1. Discharge gate valve may be partially closed or partially clogged.
2. Check valve may be partially clogged. Raise level up and down to clear.
3. Pump may be running in wrong direction. Low speed pumps can operate in reverse direction without much noise or vibration.
4. Discharge head may be too high. Check total head with gauge when pump is operating. Total head is discharge gauge pressure converted to feet plus vertical height from water level in sump to center line of pressure gauge in discharge line. Gauge should be installed on pump side of all valves. Multiply gauge pressure in pounds by 2.31 to get head in feet.
5. If pump has been in service for some time and capacity falls off, remove pump and check for wear or clogged impeller.

Motor stops and then restarts after short period but overload heaters in starter do not trip.

1. This indicates heat sensors in the motor are tripping due to excessive heat. Impeller may be partially clogged giving a sustained overload but not high enough to trip overload heater switch.
2. Motor may be operating out of liquid due to a failed level control.
3. Pump may be operating on a short cycle due to sump being too small or from water returning to sump due to a leaking check valve.

TYPICAL FM ONLY SCHEMATICS

TYPICAL SINGLE PHASE MOTOR CONNECTIONS

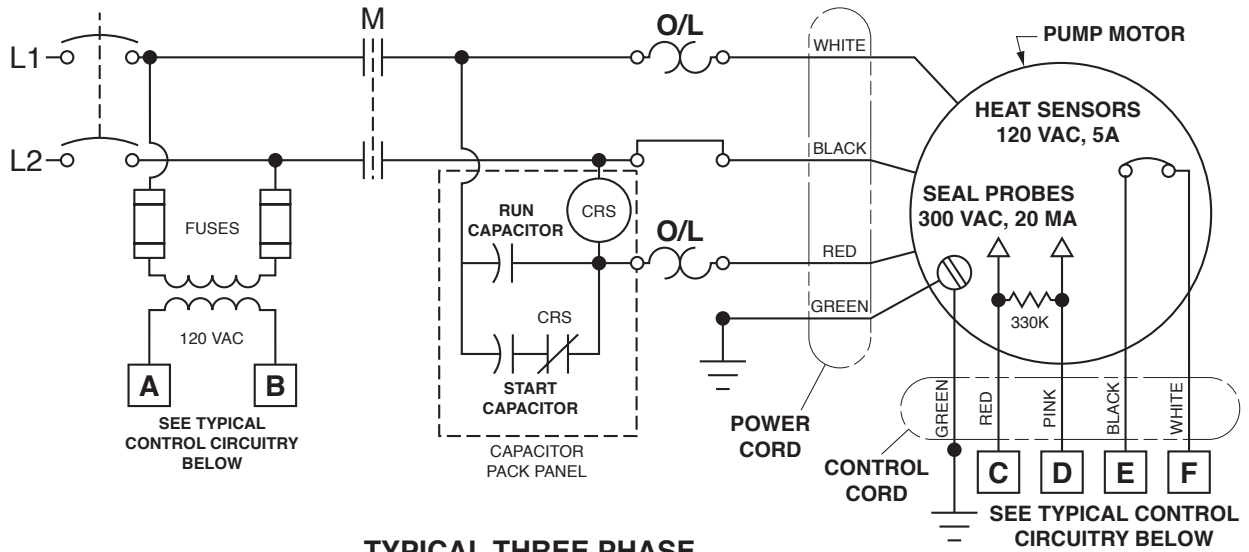

TYPICAL THREE PHASE MOTOR CONNECTIONS

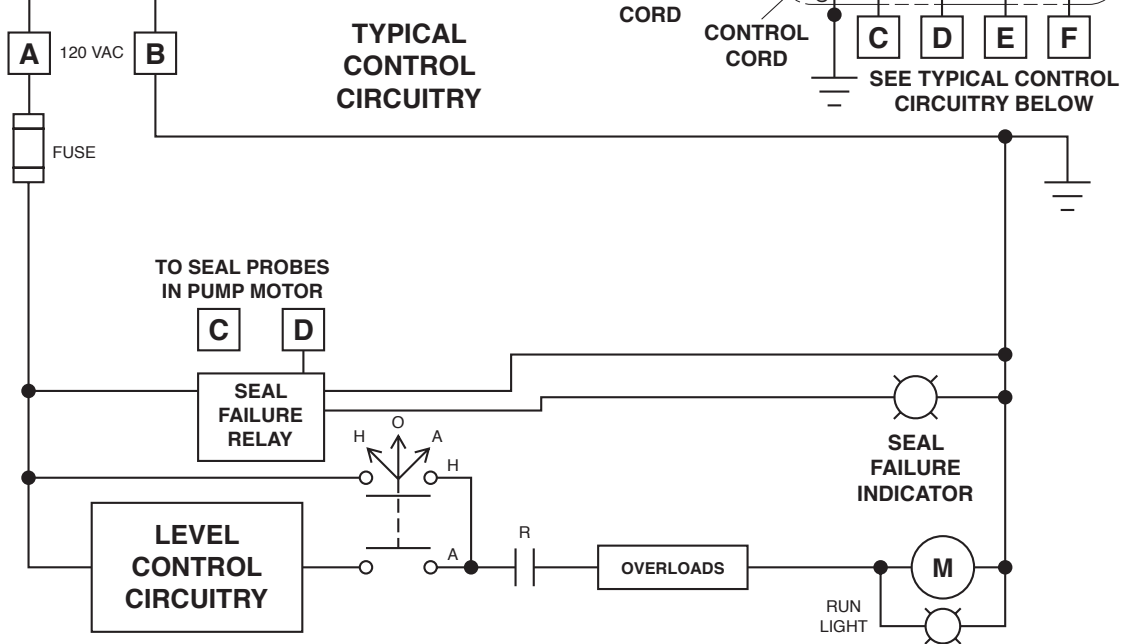
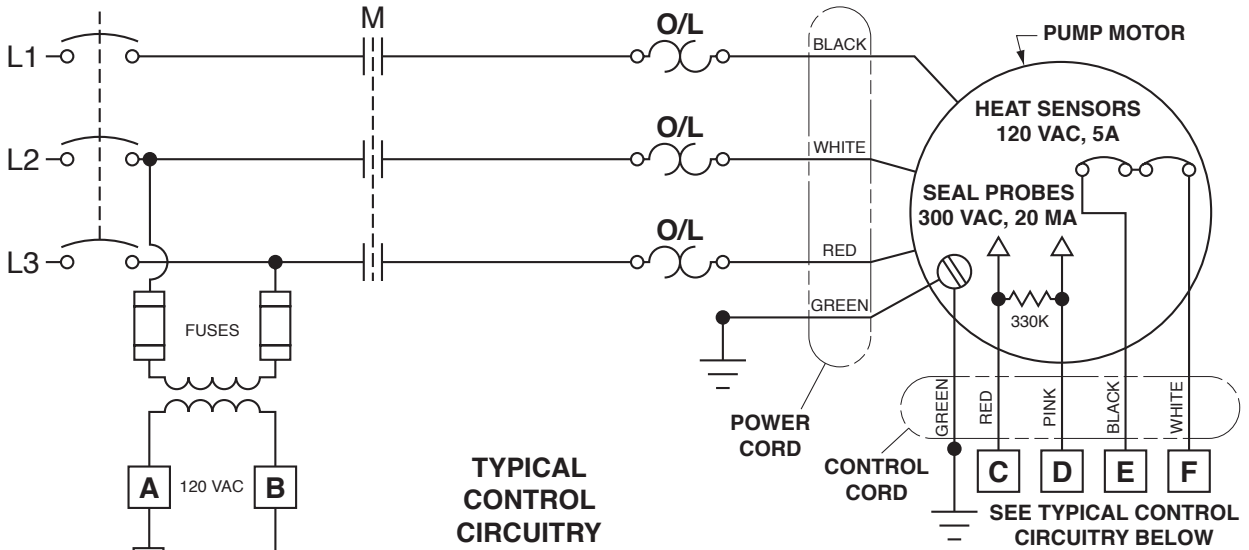

NOTE: CAPACITORS AND/OR CONTROLS SHOULD BE LOCATED OUTSIDE HAZARDOUS AREA AND ENCLOSED IN AN APPROPRIATE ENCLOSURE.

S3H Parts List

Item	Eng. No.	Description	Qty.
1	008530001	Wire Connector (230V 3Φ)	4
	005570001	Wire Connector (460V 3Φ)	6
	005570001	Wire Connector (200/230V 1Φ, 575V 3Φ)	3
2	054300025	Connection Box 200/230V 1Φ	1
	054300025	Connection Box 200/575V 3Φ	1
	054300055	Connection Box 230/460V 3Φ	1
3	005700152	Cap Screw	2
4	010540001	Gasket	1
5	008340101	O-Ring	SC 1
6	049060003	Wear Ring	1
7	005170071	Screw (Soc. Hd.)	3
8	000640031	Load Spring	1
9	000650211	Bearing, Upper	1
10	002990021	Stator Retaining Ring	1
11	005170071	Screw 1 hp 3Φ Only	4
	005170081	Screw – All Except 1 hp 3Φ	4
12	005680071	Soc. Head Capscrew	4
13	079900002	Seal Plate	1
14	071450002	Bearing Housing	1
15	082080001	Instruction Label	1
16	082060001	Capscrew	4
17	002960262	Impeller Dia. (6.65")	1
	002960282	Impeller Dia. (6.41")	1
	002960272	Impeller Dia. (6.08")	1
	002960292	Impeller Dia. (5.83")	1
	002960302	Impeller Dia. (5.41")	1
	002960322	Impeller Dia. (4.83")	1
18	049160001	Lower Seal (Ceramic), Std.	SC 1
	049160011	Lower Seal (Carbide), Opt.	C 1
19	005560031	Capscrew, Impeller	1
20	084220005	Impeller Washer	1
21	107420015	Volute Case w/Wear Ring	1
22	001500231	O-Ring	1
23	001500291	O-Ring	SC 1
24	009750121	Snap Ring	1
25	049160001	Upper Seal, Carbon/Ceramic	SC 1
26	000650181	Bearing, Lower	1
27	084720015	Seal Failure Probe	1
28	001500201	O-Ring	SC 1
29	054540011	Roll Pin	1
30	24407C223	Stator 1 hp 230V, 1Φ, 1150 RPM	1
	147152031	Stator 1 hp 200V, 1Φ, 1150 RPM	1
	24407C225	Stator 1 hp 230V, 3Φ, 1150 RPM	1
	24407C225	Stator 1 hp 460V, 3Φ, 1150 RPM	1
	24407C224	Stator 1 hp 200V, 3Φ, 1150 RPM	1
	24407C226	Stator 1 hp 575V, 3Φ, 1150 RPM	1
	24407C215	Stator 2 hp 230V, 1Φ, 1750 RPM	1
	24407C217	Stator 2 hp 230V, 3Φ, 1750 RPM	1
	24407C217	Stator 2 hp 460V, 3Φ, 1750 RPM	1
	24407C216	Stator 2 hp 200V, 3Φ, 1750 RPM	1
	24407C218	Stator 2 hp 575V, 3Φ, 1750 RPM	1
	24407C200	Stator 3 hp 230V, 1Φ, 1750 RPM	1
	24407C202	Stator 3 hp 230V, 3Φ, 1750 RPM	1
	24407C202	Stator 3 hp 460V, 3Φ, 1750 RPM	1
24407C201	Stator 3 hp 200V, 3Φ, 1750 RPM	1	
24407C203	Stator 3 hp 575V, 3Φ, 1750 RPM	1	
31	077740135	Rotor w/ Shaft 1 hp All, 1Φ, 1150 RPM	1
	077730135	Rotor w/ Shaft 1 hp All, 3Φ, 1150 RPM	1
	013290145	Rotor w/ Shaft 2 hp All, 3Φ, 1750 RPM	1

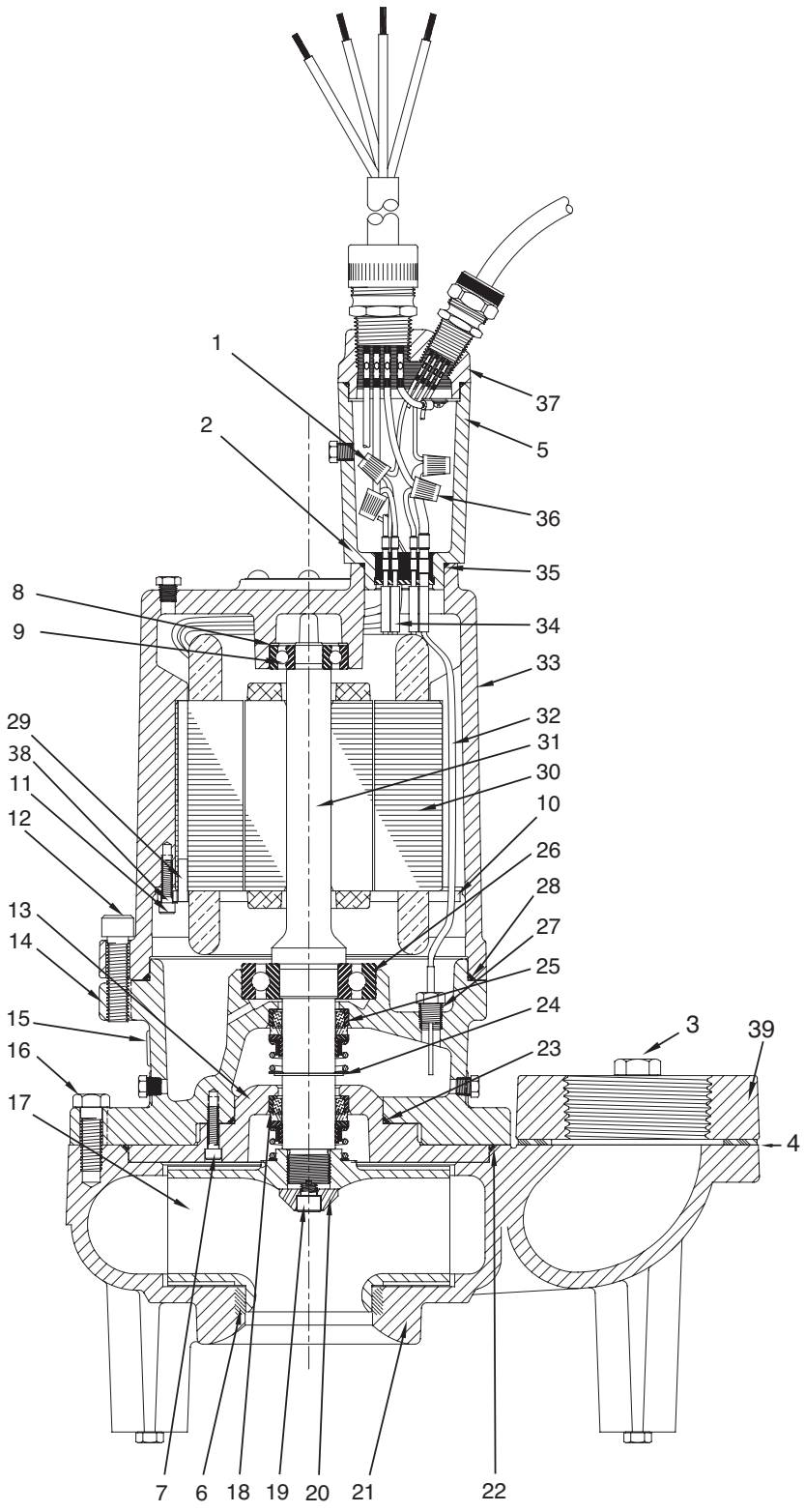

Item	Eng. No.	Description	Qty.
31	013290145	Rotor w/ Shaft 3 hp All, 1Φ, 1750 RPM	1
	013290145	Rotor w/ Shaft 3 hp All, 3Φ, 1750 RPM	1
32	060000145	Wire w/Terminal	1
33	002940022	Motor Housing All Except 1 hp 3Φ	1
34	002820011	Wire Connector All 1Φ & 200/575V 3Φ	6
	002820011	Wire Connector All 230/460V 3Φ	12
35	008340081	O-Ring	SC 1

Item	Eng. No.	Description	Qty.
36	000730001	Wire Connector (Dual Cord)	3
37	152740355	35" Cord Assembly 14-4	1
	152740345	35" Cord Assembly 12-4	1
	152740305	35" Cord Assembly 10-4	1
	152740315	35" Cord Assembly 8-4 SOOW	1
	152740325	35" Cord Assembly 8-4 W	1
38	009950081	Lockwasher	4
39	003560002	Dis. Flange	1
	517000147	Seal Kit	
	517003147	Carbide Seal Kit	

Notes: S — Parts in Seal Kit C — Parts in Carbide Seal Kit — Fill oil to above motor windings.

S3HX Parts List

Item	Eng. No.	Description	Qty.
1	152730355	35' Cord Assembly 14-4	1
	152730345	35' Cord Assembly 12-4	1
	152730305	35' Cord Assembly 10-4	1
2	005570001	Wire Connector 200/230/1ϕ/60, 200/575/3ϕ/60	3
	008530001	Wire Connector 230/3ϕ/60	4
	005570001	Wire Connector 460/3ϕ/60	6
3	008340081	O-Ring	SC 1
4	108980001	Wire Connector	4
5	108990001	Wire Connector 230/460/3ϕ/60	9
	108990001	Wire Connector 200/230/1ϕ/60	3
	108990001	Wire Connector 200/575/3ϕ/60	3
6	054540011	Roll Pin	1
7	002990021	Stator Holding Ring	1
8	000650201	Bearing (lower)	1
9	001500201	O-Ring	SC 1
10	109000015	Seal Sensor Assy	1
11	109010001	Seal Failure, Terminal	2
12	009950081	Lockwasher	4
13	109020001	Safety Wire	1
14	001500111	O-Ring	SC 1
15	002390071	Capscrew	4
16	001500231	O-Ring	SC 1
17	107530002	Seal Plate	1
18	002960262	Impeller 6.65" dia.	1
	002960282	Impeller 6.41" dia.	1
	002960272	Impeller 6.08" dia.	1
	002960292	Impeller 5.83" dia.	1
	002960302	Impeller 5.41" dia.	1
	002960322	Impeller 4.83" dia.	1
	002960332	Impeller 4.51" dia.	1
19	005700151	Bolt	2
20	084220011	Impeller Washer	1
21	005560031	Impeller Bolt	1
22	050310003	Wear Ring	1
23	049160001	Lower Seal (ceramic) Std.	S 1
	049160011	Lower Seal (carbide) Opt.	C 1
24	107420015	Volute w/Wearing Ring	1
25	005170071	Capscrew	3
26	009750031	Retainer Ring	1
27	107430002	Bearing Housing	1
28	009200011	Upper Seal	SC 1
29	005680071	Bolt	4
30	010540001	Gasket	1
31	005170081	Capscrew	4
32	24407C223	Stator 1 hp 230/1ϕ/60 1150 RPM	1
	147152031	Stator 1 hp 200/1ϕ/60 1150 RPM	1
	24407C224	Stator 1 hp 200/3ϕ/60 1150 RPM	1
	24407C226	Stator 1 hp 575/3ϕ/60 1150 RPM	1
	24407C225	Stator 1 hp 230/460/3ϕ/60 1150 RPM	1
	146940031	Stator 1 hp 230/1ϕ/60 1750 RPM	1
	146950031	Stator 1 hp 230/460/3ϕ/60 1750 RPM	1
	146952031	Stator 1 hp 200/3ϕ/60 1750 RPM	1
	146956031	Stator 1 hp 575/3ϕ/60 1750 RPM	1
	24407C215	Stator 2 hp 230/1ϕ/60 1750 RPM	1
	24407C217	Stator 2 hp 230/460/3ϕ/60 1750 RPM	1
	24407C216	Stator 2 hp 200/3ϕ/60 1750 RPM	1
	24407C218	Stator 2 hp 575/3ϕ/60 1750 RPM	1
	24407C200	Stator 3 hp 230/1ϕ/60 1750 RPM	1
	24407C202	Stator 3 hp 230/460/3ϕ/60 1750 RPM	1
	24407C203	Stator 3 hp 575/3ϕ/60 1750 RPM	1

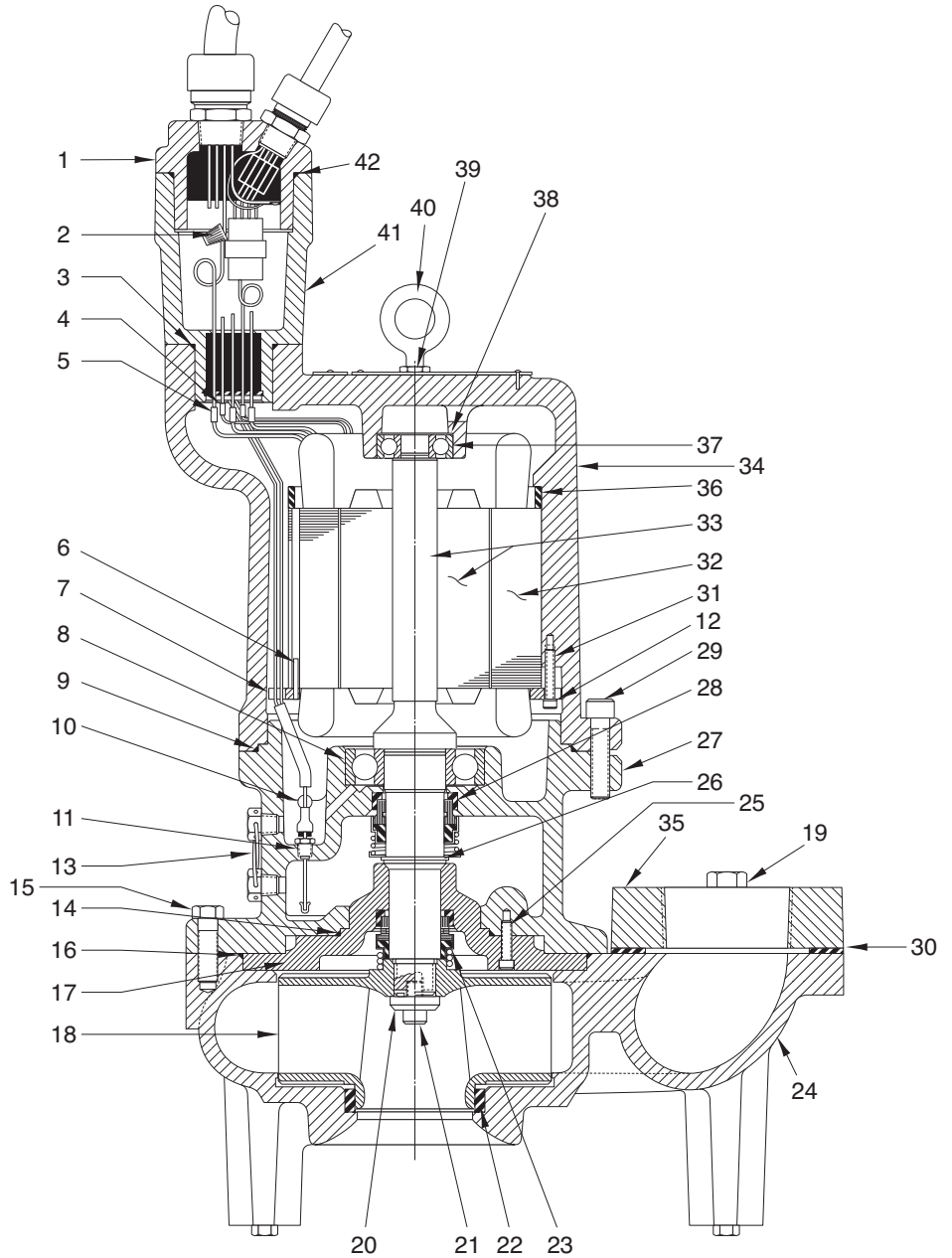

Item	Eng. No.	Description	Qty.	
33	077740145	Rotor & Shaft 1 hp 200/230/1ϕ/60 1150 RPM	1	
	077730145	Rotor & Shaft 1 hp 200/230/460/575/3ϕ/60 1150 RPM	1	
	077730145	Rotor & Shaft 1 hp 200/230/1ϕ/60 1750 RPM	1	
	007390125	Rotor & Shaft 1 hp 200/230/460/575/3ϕ/60 1750 RPM	1	
	007400175	Rotor & Shaft 2 hp 200/230/1ϕ/60 1750 RPM	1	
	077730145	Rotor & Shaft 2 hp 200/230/460/575/3ϕ/60 1750 RPM	1	
	013290175	Rotor & Shaft 3 hp 200/230/460/1ϕ/60 1750 RPM	1	
	013290175	Rotor & Shaft 3 hp 200/230/460/575/3ϕ/60 1750 RPM	1	
	34	107650022	Motor Housing 2 hp 3ϕ 1750 RPM	1
		107650032	Motor Housing – all others	1

Item	Eng. No.	Description	Qty.
35	003560002	Flange, discharge 3"	1
	003560042	Flange, discharge 4"	1
36	007360011	Spacer Ring 1/2"	1
	007360021	Spacer Ring 1"	1
37	000650211	Bearing Upper	1
38	000640031	Load Spring	1
39	010320021	Nut	2
40	21929A002	Eye Bolt	2
41	108950001	Conn. Box 230/460/3ϕ/60	1
	108950015	Conn. Box 200/230/1ϕ/60 - 200/575/3ϕ/60	1
42	008340131	O-Ring	SC 1
	517000577	Seal Kit	
	517003577	Carbide Seal Kit	

Notes: S — Parts in Seal Kit C — Parts in Carbide Seal Kit — Fill oil to above motor windings.

S4H Parts List

Item	Eng. No.	Description	Qty.
1	008530001	Wire Connector (230V 3Φ)	4
	005570001	Wire Connector (460V 3Φ)	6
	005570001	Wire Connector (200/230V 1Φ, 575V 3Φ)	3
2	054300025	Connection Box 200/230V 1Φ	1
	054300025	Connection Box 200/575V 3Φ	1
	054300055	Connection Box 230/460V 3Φ	1
3	19105A044	Cap Screw	2
4	010540001	Gasket	1
5	049060003	Wear Ring	1
6	005170071	Screw (Soc. Hd.)	3
7	009950081	Lockwasher	4
8	000640031	Load Spring	1
9	000650211	Bearing, Upper	1
10	002990021	Stator Retaining Ring	1
11	005170071	Screw 1 hp 3Φ Only	4
	005170081	Screw - All Except 1 hp 3Φ	4
12	005680071	Soc. Head Capscrew	4
13	079900002	Seal Plate	1
14	071450002	Bearing Housing	1
15	003560042	Dis. Flange	1
16	19103A043	Capscrew	4
17	079920112	Impeller 7-1/2" Dia. (7.54)	1
	079920132	Impeller 7-1/8" Dia. (7.12)	1
	079920202	Impeller 6-1/2" Dia. (6.51)	1
	079920142	Impeller 6-9/32" Dia. (6.28)	1
	079920162	Impeller 5-11/16" Dia. (5.70)	1
	079920152	Impeller 5-19/32" Dia. (5.61)	1
18	049160001	Lower Seal (Ceramic, Std.)	1
	049160011	Lower Seal (Carbide), Opt.	1
19	005560031	Capscrew, Impeller	1
20	084220011	Impeller Washer	1
21	107410015	Volute Case w/Wear Ring	1
22	001500231	O-Ring	1
23	001500291	O-Ring	1
24	009750121	Snap Ring	1
25	049160001	Upper Seal, Carbon/Ceramic	1
26	000650181	Bearing, Lower	1
27	084720015	Seal Failure Probe	1
28	001500201	O-Ring	1
29	054540011	Roll Pin	1
30	147152031	Stator 1 hp 200/1Φ/60 1150 RPM	1
	24407C223	Stator 1 hp 230/1Φ/60 1150 RPM	1
	24407C224	Stator 1 hp 200/3Φ/60 1150 RPM	1
	24407C225	Stator 1 hp 230/460/3Φ/60 1150 RPM	1
	24407C226	Stator 1 hp 575/3Φ/60 1150 RPM	1
	24407C217	Stator 2 hp 230/460/3Φ/60 1750 RPM	1
	24407C216	Stator 2 hp 200/3Φ/60 1750 RPM	1
	24407C215	Stator 2 hp 230/1Φ/60 1750 RPM	1
	24407C218	Stator 2 hp 575/3Φ/60 1750 RPM	1
	147172031	Stator 2 hp 200/1Φ/60 1150 RPM	1
	24407C231	Stator 2 hp 230/1Φ/60 1150 RPM	1
	24407C232	Stator 2 hp 200/3Φ/60 1150 RPM	1
	24407C233	Stator 2 hp 230/460/3Φ/60 1150 RPM	1
	24407C234	Stator 2 hp 575/3Φ/60 1150 RPM	1
	24407C200	Stator 3 hp 230/1Φ/60 1750 RPM	1
	24407C201	Stator 3 hp 200/3Φ/60 1750 RPM	1
	24407C202	Stator 3 hp 230/460/3Φ/60 1750 RPM	1
	24407C203	Stator 3 hp 575/3Φ/60 1750 RPM	1
	24407C204	Stator 5 hp 230/1Φ/60 1750 RPM	1
	24407C205	Stator 5 hp 200/3Φ/60 1750 RPM	1
24407C206	Stator 5 hp 230/460/3Φ/60 1750 RPM	1	
24407C207	Stator 5 hp 575/3Φ/60 1750 RPM	1	
24407C209	Stator 7-1/2 hp 200/230/460/3Φ/60 1750 RPM	1	
24407C210	Stator 7-1/2 hp 575/3Φ/60 1750 RPM	1	

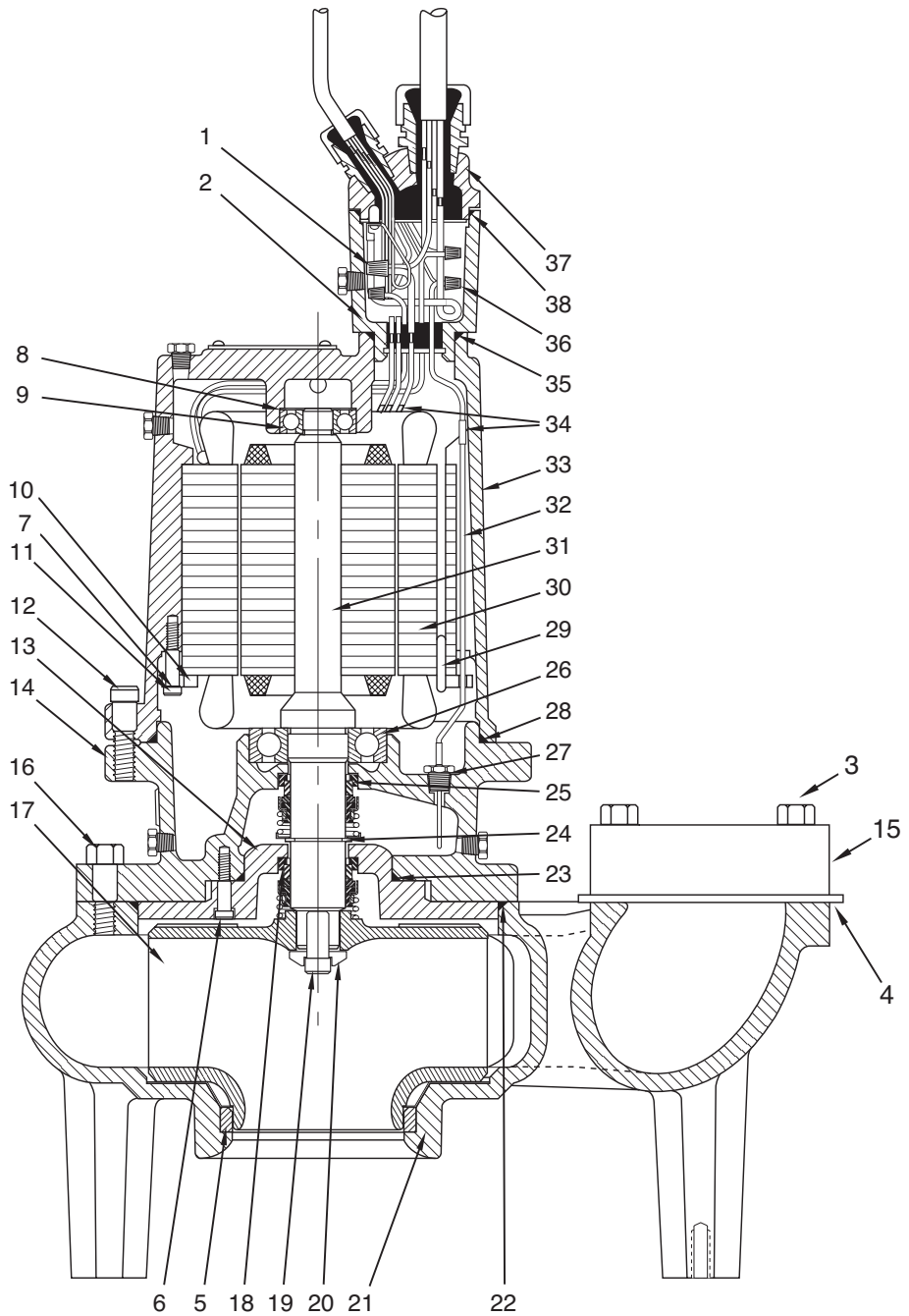

Item	Eng. No.	Description	Qty.
31	077740135	Rotor w/Shaft 1 hp All 1Φ, 1150 RPM	1
	077730135	Rotor w/Shaft 1 hp All 3Φ, 1150 RPM	1
	008650145	Rotor w/Shaft 2 hp All 1Φ, 1150 RPM	1
	009190145	Rotor w/Shaft 2 hp All 3Φ, 1150 RPM	1
	007400145	Rotor w/Shaft 2 hp All 1Φ, 1750 RPM	1
	109220145	Rotor w/Shaft 3 hp All 1Φ, 1750 RPM	1
	013290145	Rotor w/Shaft 2-7-1/2 hp All 3Φ, 1750 RPM	1
	060000141	Wire w/Terminal	1
32	002940012	Motor Housing 1 hp 3Φ Only	1
	002940022	Motor Housing All Except 1 hp 3Φ	1
34	12672A001	Wire Connector All 1Φ & 200/575V 3Φ	6
	12672A001	Wire Connector All 230/460V 3Φ	12
35	008340081	O-Ring	1
36	000730011	Wire Connector (Dual Cord)	3

Item	Eng. No.	Description	Qty.
37	152740355	35' Cord Assembly 14-4	1
	152740345	35' Cord Assembly 12-4	1
	152740305	35' Cord Assembly 10-4	1
	152740315	35' Cord Assembly 8-4 SOOW	1
	152740325	35' Cord Assembly 8-4 W	1
38	008340101	O-Ring	1

Note: Fill oil to above motor windings.

S4HX Parts List

Item	Eng. No.	Description	Qty.
1	152730355	35' Cord Assembly 14-4	1
	152730345	35' Cord Assembly 12-4	1
	152730305	35' Cord Assembly 10-4	1
	152730315	35' Cord Assembly 8-4 S00W	1
	152730335	35' Cord Assembly 8-4 W	1
2	008530001	Connector 2 hp 230/460/3Φ	4
	005570001	Connector 1-5 hp 200/230/1Φ	3
	024940001	Connector 7-1/2 hp 200/230/460/575/3Φ	4
3	008340081	O-Ring	SC 1
4	108980001	Connector	4
5	108990001	Connector 230/460/3Φ	9
6	054540011	Roll Pin	1
7	002990021	Stator Retaining Ring	1
8	000650201	Lower Bearing	1
9	001500201	O-Ring	SC 1
10	109000015	Resistor Assy	1
11	109010001	Seal Failure Terminal	2
12	003560042	Discharge Flange	1
13	109020001	Safety Wire	1
14	05876A106	O-Ring	SC 1
15	19103A043	Capscrew	4
16	001500231	O-Ring	SC 1
17	107530002	Seal Plate	1
18	079920152	Impeller 5.61"	1
	079920162	Impeller 5.07"	1
	079920142	Impeller 6.28"	1
	079920202	Impeller 6.51"	1
	079920182	Impeller 7.10"	1
	079920132	Impeller 7.12"	1
	079920112	Impeller 7.54"	1
19	19101A017	Capscrew SST	3
20	084220011	Washer (Shaft)	1
21	005560031	Capscrew SST	1
22	049060003	Wear Ring	1
23	049160001	Lower Seal Ceramic (std)	S 1
	049160011	Lower Seal Carbide (opt)	C 1
24	107410015	Volute w/Ring	1
25	005170071	Capscrew SST	3
26	009750031	Retain Ring	1
27	107430002	Bearing Housing	1
28	009200011	Upper Seal	SC 1
29	005680071	Capscrew	4
30	005700151	Capscrew	2
31	005170081	Capscrew	4
32	24407C223	Stator 1 hp 230/1Φ 1150 RPM	1
	147152031	Stator 1 hp 200/1Φ 1150 RPM	1
	24407C225	Stator 1 hp 230/460/3Φ 1150 RPM	1
	24407C224	Stator 1 hp 200/3Φ 1150 RPM	1
	24407C226	Stator 1 hp 575/3Φ 1150 RPM	1
	24407C231	Stator 2 hp 230/1Φ 1150 RPM	1
	147172031	Stator 2 hp 200/1Φ 1150 RPM	1
	24407C233	Stator 2 hp 230/460/3Φ 1150 RPM	1
	24407C232	Stator 2 hp 200/3Φ 1150 RPM	1
	24407C234	Stator 2 hp 575/3Φ 1150 RPM	1
	24407C215	Stator 2 hp 230/1Φ 1750 RPM	1
	24407C217	Stator 2 hp 230/460/3Φ 1750 RPM	1
	24407C216	Stator 2 hp 200/3Φ 1750 RPM	1
	24407C218	Stator 2 hp 575/3Φ 1750 RPM	1
	24407C200	Stator 3 hp 230/1Φ 1750 RPM	1
	24407C202	Stator 3 hp 230/460/3Φ 1750 RPM	1
	24407C201	Stator 3 hp 200/3Φ 1750 RPM	1
24407C203	Stator 3 hp 575/3Φ 1750 RPM	1	
24407C206	Stator 5 hp 230/460/3Φ 1750 RPM	1	

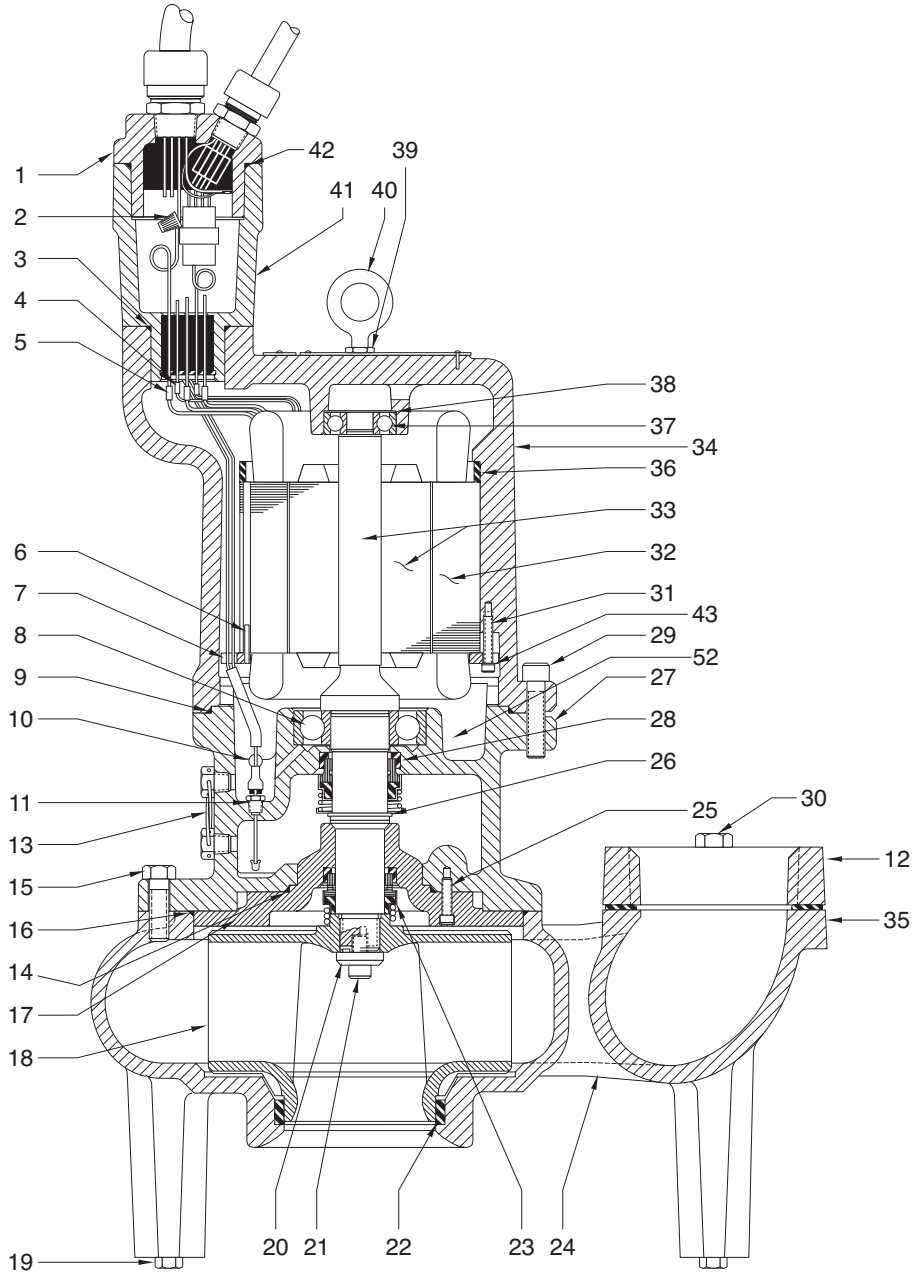

Item	Eng. No.	Description	Qty.
32	24407C205	Stator 5 hp 200/3Φ 1750 RPM	1
	24407C207	Stator 5 hp 575/3Φ 1750 RPM	1
	24407C209	Stator 7-1/2 hp 200/230/460/3Φ/60 1750 RPM	1
	24407C210	Stator 7-1/2 hp 575/3Φ 1750 RPM	1
33	077740145	Rotor w/Shaft 1 hp 1Φ 1150 RPM	1
	077730155	Rotor w/Shaft 1 hp 3Φ 1150 RPM	1
	008650155	Rotor w/Shaft 2 hp 1Φ 1150 RPM	1
	009190155	Rotor w/Shaft 2 hp 3Φ 1150 RPM	1
	007400175	Rotor w/Shaft 2 hp 1Φ 1750 RPM	1
	007410125	Rotor w/Shaft 2 hp 3Φ 1750 RPM	1
	013290175	Rotor w/Shaft 3 hp 1Φ 1750 RPM	1
013290175	Rotor w/Shaft 3-5 hp 3Φ 1750 RPM	1	
013290175	Rotor w/Shaft 7-1/2 hp 3Φ 1750 RPM	1	
34	107650022	Motor Housing	1
35	010540001	Gasket	1

Item	Eng. No.	Description	Qty.
36	007360011	Spacer 1-2 hp 3Φ 1150 RPM 2 hp 1Φ & 3Φ 1750 RPM	1
	007360021	Spacer 1 hp 1Φ 1150 RPM	1
37	000650211	Upper Bearing	1
38	000640031	Bearing Adj. Spring	1
39	010320021	Nut	2
40	21929A002	Eye Bolt	2
41	108950005	Conn. Box 3Φ 230/460	1
	108950015	Conn. Box 1Φ 200/575, 3Φ 200/275	1
42	008340131	O-Ring	SC 1
43	009950081	Washer	4
	517000577	Seal Kit	
	517003577	Carbide Seal Kit	

Notes: S — Parts in Seal Kit C — Parts in Carbide Seal Kit — Fill oil to above motor windings.

S3N Parts List

Item	Eng. No.	Description	Qty.
1	008530001	Wire Connector (230V 3Φ Only)	2
	005570001	Wire Connector (460/3Φ/60)	6
	005570001	Wire Connector (200/230/1Φ/60 & 200/575/3Φ/60)	3
2	12672A001	Wire Connector 575/3Φ/60 & 200/3Φ/60	6
	12672A001	Wire Connector 230/460/3Φ/60	12
3	008340081	O-Ring	SC 1
4	000730011	Wire Connector (Dual Cord)	3
5	054300025	Connection Box Assy. 200/3Φ/60 & 200/1Φ/60	1
	054300025	Connection Box Assy. 200/1Φ/60 & 575/3Φ/60	1
	054300055	Connection Box Assy. 230/460/3Φ/60	1
6	000650211	Upper Bearing	1
7	19100A029	Capscrew	2
8	000640031	Load Spring	1
9	008340101	O-Ring	SC 1
10	21929A002	Eye Bolt	2
11	010320021	Jam Nut	2
12	002990021	Stator Retaining Ring	1
13	06106A019	Soc. Hd. Capscrew 1 hp 3Φ	4
	06106A019	Soc. Hd. Capscrew All Other hp & Φ	4
14	005680071	Soc. Hd. Capscrew	4
15	079900002	Seal Housing	1
16	071450002	Bearing Housing	1
17	19101A010	Capscrew	2
18	19103A043	Hex Hd. Capscrew	4
19	001500231	O-Ring	SC 1
20	005170071	Soc. Hd. Capscrew	3
21	049160001	Seal (Ceramic) Std.	SC 2
	049160011	Seal (Carbide) Opt.	C 1
22	084220011	Impeller Washer	1
23	005560031	Soc. Hd. Capscrew	1
24	079920002	Impeller 8.00" Dia.	1
	079920112	Impeller 7.54" Dia.	1
	079920012	Impeller 7.50" Dia.	1
	079920232	Impeller 6.90" Dia.	1
	079920252	Impeller 6.37" Dia.	1
	079920142	Impeller 6.28" Dia.	1
	079920162	Impeller 5.70" Dia.	1
	079920272	Impeller 5.54" Dia.	1
25	049060013	Wear Ring	1
26	152010015	Volute Case Assy. (Includes Wear Ring)	1
27	001500291	O-Ring	SC 1
28	009750121	Snap Ring	1
29	002940012	Motor Housing 1 hp 3Φ Only	1
	002940022	Motor Housing All Other hp & Φ	1
30	000650181	Lower Bearing	1
31	084720015	Seal Failure Assy.	1
32	152740355	35" Cord Assembly 14-4	1
	152740345	35" Cord Assembly 12-4	1
	152740305	35" Cord Assembly 10-4	1
	152740315	35" Cord Assembly 8-4 500W	1
	152740325	35" Cord Assembly 8-4 W	1
	152740325	35" Cord Assembly 8-4 W	1
33	001500571	O-Ring	SC 1
34	054540011	Spring Pin	1
35	147152031	Stator 1 hp 200/1Φ/60 1150 RPM	1
	24407C223	Stator 1 hp 230/1Φ/60 1150 RPM	1
	24407C224	Stator 1 hp 200/3Φ/60 1150 RPM	1
	24407C225	Stator 1 hp 230/460/3Φ/60 1150 RPM	1
	24407C226	Stator 1 hp 575/3Φ/60 1150 RPM	1
	24407C226	Stator 1 hp 575/3Φ/60 1150 RPM	1

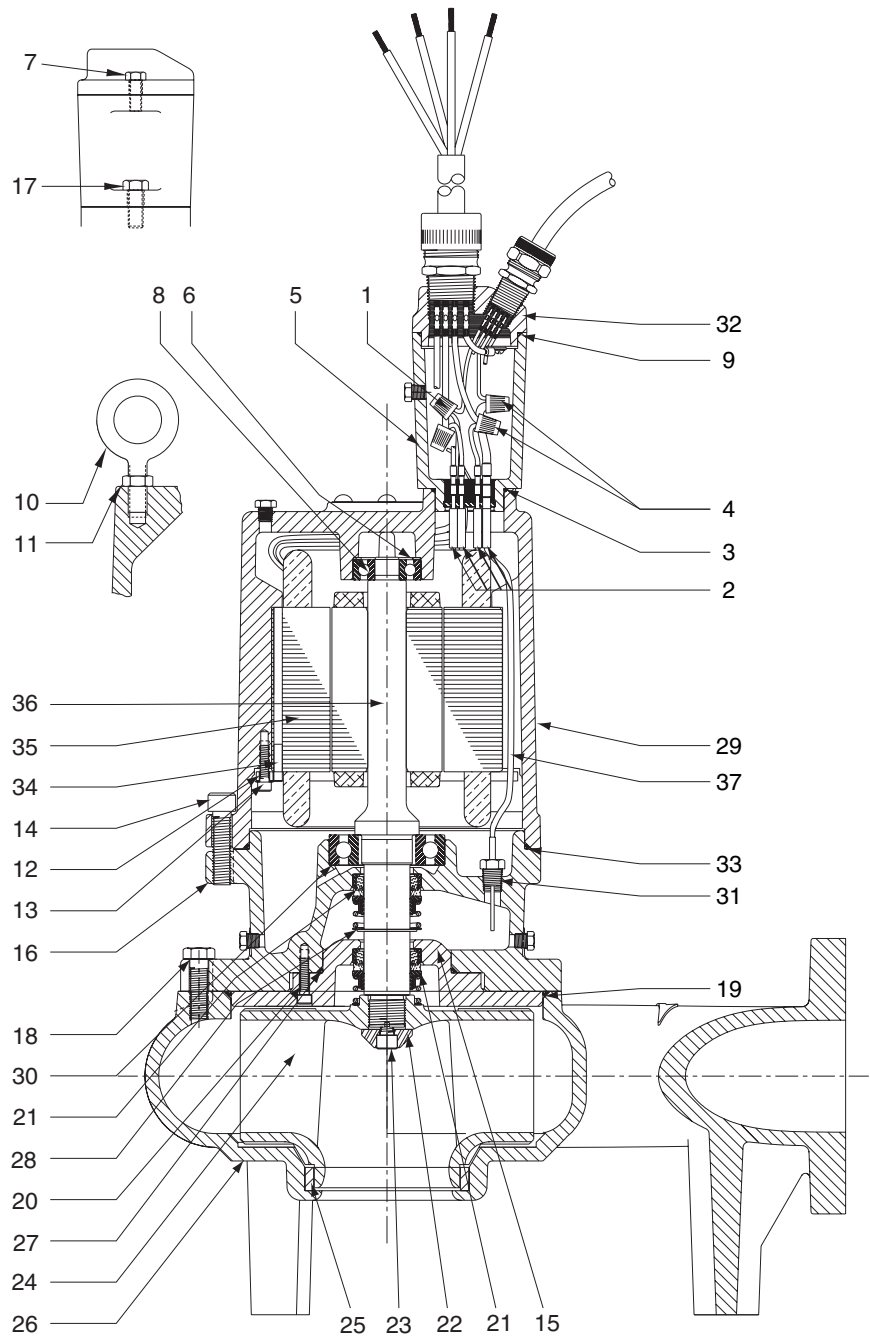

Item	Eng. No.	Description	Qty.
35	24407C200	Stator 3 hp 230/1Φ/60 1750 RPM	1
	24407C201	Stator 3 hp 200/3Φ/60 1750 RPM	1
	24407C202	Stator 3 hp 230/460/3Φ/60 1750 RPM	1
	24407C203	Stator 3 hp 575/3Φ/60 1750 RPM	1
	24407C204	Stator 5 hp 230/1Φ/60 1750 RPM	1
	24407C205	Stator 5 hp 200/3Φ/60 1750 RPM	1
	24407C206	Stator 5 hp 230/460/3Φ/60 1750 RPM	1
	24407C207	Stator 5 hp 575/3Φ/60 1750 RPM	1
	24407C209	Stator 7-1/2 hp 200/230/460/3Φ/60 1750 RPM	1
	24407C210	Stator 7-1/2 hp 575/3Φ/60 1750 RPM	1

Item	Eng. No.	Description	Qty.	
36	013290145	Rotor & Shaft Assy. 5 hp	1	
	013290145	Rotor & Shaft Assy. 7.5 hp	1	
	077740135	Rotor & Shaft Assy. 1 hp 200/230/1Φ/60	1	
	077730135	Rotor & Shaft Assy. 1 hp 200/230/460/575/3Φ/60	1	
	008650145	Rotor & Shaft Assy. 2 hp 200/230/1Φ/60	1	
	009190145	Rotor & Shaft Assy. 2 hp 200/230/460/575/3Φ/60	1	
	013290145	Rotor & Shaft Assy. 3 hp 200/230/1Φ/60	1	
	013290145	Rotor & Shaft Assy. 3 & 5 hp 200/230/460/575/3Φ/60	1	
	37	060000141	Seal Failure Wire Assy.	1
		517000167	Seal Kit	1
517003167		Carbide Seal Kit	1	

Notes: S — Parts in Seal Kit C — Parts in Carbide Seal Kit — Fill oil to above motor windings.

S3NX Parts List

Item	Eng. No.	Description	Qty.
1	152730355	35' Cord Assembly 14-4	1
	152730345	35' Cord Assembly 12-4	1
	152730305	35' Cord Assembly 10-4	1
	152730315	35' Cord Assembly 8-4 500W	1
	152730335	35' Cord Assembly 8-4 W	1
2	005570001	Connector 200/230/1 Φ /60 & 200/575/3 Φ /60 (1-5 hp)	3
	008530001	Connector 230/460/3 Φ /60 (1.5-5 hp)	4
	024940001	Connector 200/230/460/575/3 Φ /60 (7-1/2 hp)	4
3	008340081	O-Ring	SC 1
4	108980001	Connector	4
5	108990001	Connector	9
6	054540011	Roll Pin	1
7	002990021	Stator Holding Ring	1
8	000650201	Lower Bearing	1
9	001500201	O-Ring	SC 1
10	109000015	Resistor Assy	1
11	109010001	Terminal Seal Failure	2
12	008340131	O-Ring	SC 1
13	109020001	Safety Wire	1
14	001500111	O-Ring	SC 1
15	002390071	Bolt	4
16	001500231	O-Ring	SC 1
17	107530002	Seal Plate	1
18	079920212	Impeller 7.65" dia.	1
	079920012	Impeller 7.50" dia.	1
	079920232	Impeller 6.90" dia.	1
	079920252	Impeller 6.37" dia.	1
	079920142	Impeller 6.29" dia.	1
	079920162	Impeller 5.70" dia.	1
	079920272	Impeller 5.54" dia.	1
19	002380061	Capscrew, S/S (non UL)	3
	002380281	Capscrew Bronze (UL)	3
20	084220011	Washer	1
21	005560031	Capscrew S/S	1
22	049060013	Wear Ring	1
23	049160001	Lower Seal (ceramic) std.	S 1
	049160011	Lower Seal (carbide) opt.	C 1
24	152010015	Volute w/Wearing Ring	1
25	005170071	Capscrew S/S	3
26	009750031	Retainer Ring	1
27	107430002	Bearing Housing	1
28	009200011	Upper Seal	SC 1
29	005680071	Capscrew	4
30	009950081	Washer	4
31	005170081	Capscrew	4
32	24407C223	Stator 1 hp 230/1 Φ /60 1150	1
	147152031	Stator 1 hp 200/1 Φ /60 1150	1
	24407C225	Stator 1 hp 230/460/3 Φ /60 1150	1
	24407C224	Stator 1 hp 200/3 Φ /60 1150	1
	24407C226	Stator 1 hp 575/3 Φ /60 1150	1
	24407C231	Stator 2 hp 230/1 Φ /60 1150	1
	147172031	Stator 2 hp 200/1 Φ /60 1150	1
	24407C233	Stator 2 hp 230/460/3 Φ /60 1150	1
	24407C232	Stator 2 hp 200/3 Φ /60 1150	1
	24407C234	Stator 2 hp 575/3 Φ /60 1150	1
	24407C200	Stator 3 hp 230/1 Φ /60 1750	1
	24407C202	Stator 3 hp 230/460/3 Φ /60 1750	1
	24407C201	Stator 3 hp 200/3 Φ /60 1750	1
	24407C203	Stator 3 hp 575/3 Φ /60 1750	1
	24407C204	Stator 5 hp 230/1 Φ /60 1750	1
	24407C206	Stator 5 hp 230/460/3 Φ /60 1750	1
	24407C205	Stator 5 hp 200/3 Φ /60 1750	1
	24407C207	Stator 5 hp 575/3 Φ /60 1750	1
	24407C209	Stator 7-1/2 hp 200/230/460/3 Φ /60 1750	1
	24407C210	Stator 7-1/2 hp 575/3 Φ /60 1750	1

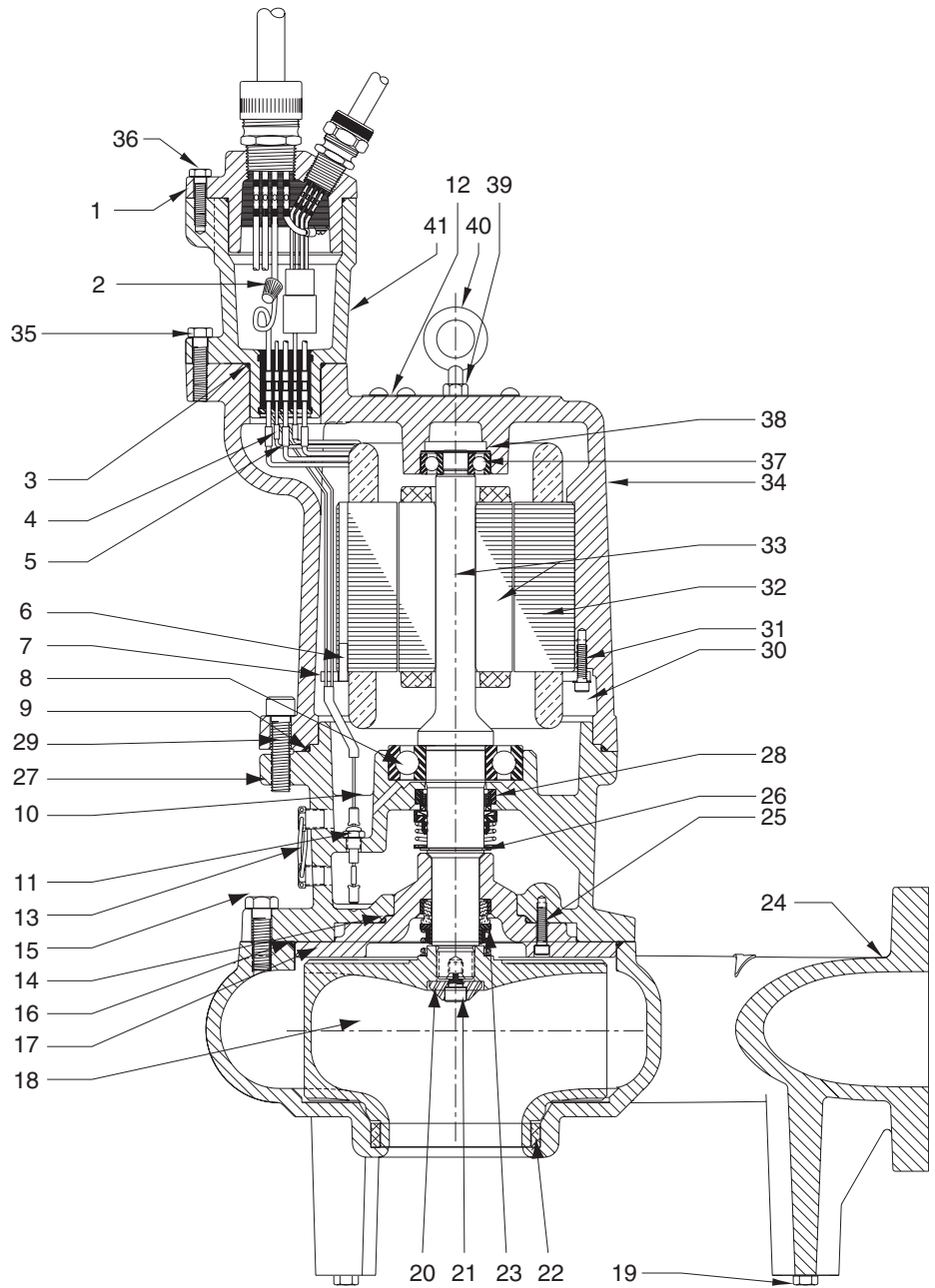

Item	Eng. No.	Description	Qty.
33	077740145	Rotor & Shaft 1 hp 1 Φ 1150	1
	077730145	Rotor & Shaft 1 hp 3 Φ 1150	1
	013290175	Rotor & Shaft 2 hp 1 Φ 1150	1
	007400175	Rotor & Shaft 2 hp 3 Φ 1150	1
	007400175	Rotor & Shaft 2 hp 1 Φ 1750	1
	007410125	Rotor & Shaft 2 hp 3 Φ 1750	1
	013290175	Rotor & Shaft 3 hp 1 Φ 1750	1
	013290175	Rotor & Shaft 3-5 hp 3 Φ 1750	1
34	107650032	Housing 1 hp 3 Φ 1150, 2 hp 3 Φ 1750	1
	107650022	Housing (all others)	1

Item	Eng. No.	Description	Qty.
35	002380061	Capscrew	2
36	001010071	Capscrew	2
37	000650211	Upper Bearing	1
38	000640031	Load Spring	1
39	010320021	Nut	2
40	005890021	Bolt	2
	108950005	Conn. Box 200/3 Φ /60, 230/460/3 Φ /60	1
	108950015	Conn. Box 200/230/1 Φ /60, 575/3 Φ /60	1
	517000577	Seal Kit	
	517003577	Carbide Seal Kit	

Notes: S — Parts in Seal Kit C — Parts in Carbide Seal Kit — Fill oil to above motor windings.

S4N Parts List

Item	Eng. No.	Description	Qty.
1	008530001	Wire Connector (230V 3Φ Only)	2
	005570001	Wire Connector (460/3Φ/60)	6
	005570001	Wire Connector (200/230/1Φ/60 & 200/575/3Φ/60)	3
2	013290145	Rotor & Shaft Assy. 7.5 hp	1
	077740135	Rotor & Shaft Assy. 1 hp 200/230/1Φ/60	1
	077730135	Rotor & Shaft Assy. 1 hp 200/230/460/575/3Φ/60	1
	008650145	Rotor & Shaft Assy. 2 hp 200/230/1Φ/60	1
	009190145	Rotor & Shaft Assy. 2 hp 200/230/460/575/3Φ/60	1
	013290145	Rotor & Shaft Assy. 3 & 5 hp 200/230/1Φ/60	1
	013290145	Rotor & Shaft Assy. 3 & 5 hp 200/230/460/575/3Φ/60	1
3	060000141	Seal Failure Wire Assy.	1
4	000730011	Wire Connector (Dual Cord)	3
5	054300025	Connection Box (200/231/1Φ/60, 575/3Φ/60 & 200/3Φ/60)	1
	054300055	Connection Box Assy. 230/460/3Φ/60	1
6	000650211	Upper Bearing	1
7	002940012	Motor Housing 1 hp 3Φ Only	1
	002940022	Motor Housing All Other hp & Φ	1
8	000640031	Load Spring	1
9	12672A001	Wire Connector 1F 575/3Φ/60 & 200/3Φ/60	6
	12672A001	Wire Connector 230/460/3Φ/60	12
10	008340081	O-Ring	1
11	008340101	O-Ring	1
12	002990021	Stator Retaining Ring	1
13	06106A019	Soc. Hd. Capscrew 1 hp 3Φ	4
	06106A019	Soc. Hd. Capscrew All Other hp & Φ	4
14	005680071	Soc. Hd. Capscrew	4
15	079900002	Seal Housing	1
16	071450002	Bearing Housing	1
17	152740355	35' Cord Assembly 14-4	1
	152740345	35' Cord Assembly 12-4	1
	152740305	35' Cord Assembly 10-4	1
	152740315	35' Cord Assembly 8-4 500W	1
	152740325	35' Cord Assembly 8-4 W	1
18	19103A043	Hex Hd. Capscrew	4
19	001500231	O-Ring	1
20	005170071	Soc. Hd. Capscrew	3
21	049160001	Seal (Ceramic) Std.	2
	049160011	Seal (Carbide) Opt.	1
22	084220011	Impeller Washer	1
23	005560031	Soc. Hd. Capscrew	1
24	153120002	Impeller 8.00" Dia.	1
	153120012	Impeller 7.50" Dia.	1
	153120022	Impeller 7.00" Dia.	1
	153120032	Impeller 6.50" Dia.	1
	153120042	Impeller 6.00" Dia.	1
	153120052	Impeller 5.50" Dia.	1
25	049060013	Wear Ring	1
26	079930015	Volute Case Assy. (Includes Wear Ring)	1
27	001500291	O-Ring	1
28	009750121	Snap Ring	1
29	082060011	Instruction Plate	1
30	000650181	Lower Bearing	1
31	084720015	Seal Failure Assy.	1
32	007360021	Spacer Ring (200/230/1Φ/60 1 hp)	1
	007360011	Spacer Ring (200/230/460 & 575/3Φ/60 2 hp) & (200/230/1Φ/60 3 hp)	1
33	001500571	O-Ring	1
34	054540011	Spring Pin	1

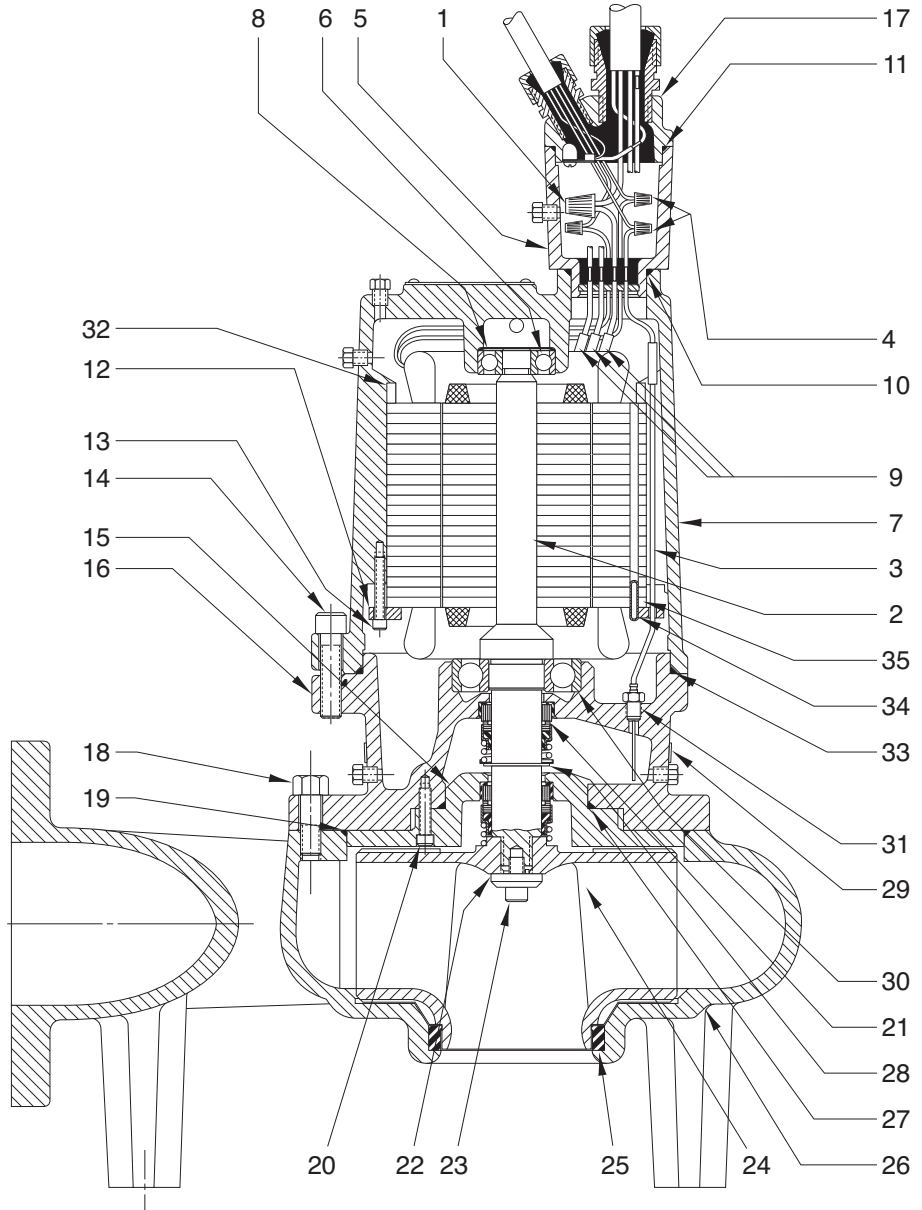

Item	Eng. No.	Description	Qty.
35	147152031	Stator 1 hp 200/1Φ/60 1150 RPM	1
	24407C223	Stator 1 hp 230/1Φ/60 1150 RPM	1
	24407C224	Stator 1 hp 200/3Φ/60 1150 RPM	1
	24407C225	Stator 1 hp 230/460/3Φ/60 1150 RPM	1
	24407C226	Stator 1 hp 575/3Φ/60 1150 RPM	1
	147172031	Stator 2 hp 200/1Φ/60 1150 RPM	1
	24407C231	Stator 2 hp 230/1Φ/60 1150 RPM	1
	24407C232	Stator 2 hp 200/3Φ/60 1150 RPM	1
	24407C233	Stator 2 hp 230/460/3Φ/60 1150 RPM	1
	24407C234	Stator 2 hp 575/3Φ/60 1150 RPM	1
	24407C217	Stator 2 hp 230/460/3Φ/60 1750 RPM	1
	24407C216	Stator 2 hp 200/3Φ/60 1750 RPM	1
	24407C215	Stator 2 hp 230/1Φ/60 1750 RPM	1

Item	Eng. No.	Description	Qty.
35	24407C218	Stator 2 hp 575/3Φ/60 1750 RPM	1
	24407C200	Stator 3 hp 230/1Φ/60 1750 RPM	1
	24407C201	Stator 3 hp 200/3Φ/60 1750 RPM	1
	24407C202	Stator 3 hp 230/460/3Φ/60 1750 RPM	1
	24407C203	Stator 3 hp 575/3Φ/60 1750 RPM	1
	24407C204	Stator 5 hp 230/1Φ/60 1750 RPM	1
	24407C205	Stator 5 hp 200/3Φ/60 1750 RPM	1
	24407C206	Stator 5 hp 230/460/3Φ/60 1750 RPM	1
	24407C207	Stator 5 hp 575/3Φ/60 1750 RPM	1
	24407C209	Stator 7-1/2 hp 200/230/460/3Φ/60 1750 RPM	1
	24407C210	Stator 7-1/2 hp 575/3Φ/60 1750 RPM	1

Note: Fill oil to above motor windings.

S4NX Parts List

Item	Eng. No.	Description	Qty.
1	152730355	35' Cord Assembly 14-4	1
	152730345	35' Cord Assembly 12-4	1
	152730305	35' Cord Assembly 10-4	1
	152730315	35' Cord Assembly 8-4 500W	1
	152730335	35' Cord Assembly 8-4 W	1
2	005570001	Connector 200/230/1 Φ /60 & 200/575/3 Φ /60 (1-5 hp)	3
	008530001	Connector 230/460/3 Φ /60 (2-5 hp)	4
	024940001	Connector 200/230/460/575/3 Φ /60 (7-1/2 hp)	4
3	008340081	O-Ring	1
4	108980001	Connector	4
5	108990001	Connector	9
6	054540011	Roll Pin	1
7	002990021	Stator Holding Ring	1
8	08565A027	Lower Bearing	1
9	001500201	O-Ring	1
10	109000015	Resistor Assy	1
11	109010001	Terminal Seal Failure	2
12	108950005	Conn. Box 200/3 Φ /60, 230/460/3 Φ /60	1
	108950015	Conn. Box 200/230/1 Φ /60, 575/3 Φ /60	1
14	001500111	O-Ring	1
15	002390071	Bolt	4
16	001500231	O-Ring	1
17	107530002	Seal Plate	1
18	153120002	Impeller 8.00" dia.	1
	153120012	Impeller 7.50" dia.	1
	153120022	Impeller 7.00" dia.	1
	153120032	Impeller 6.50" dia.	1
	153120042	Impeller 6.00" dia.	1
	153120052	Impeller 5.50" dia.	1
19	002380061	Capscrew, SST	3
20	084220011	Washer	1
21	005560031	Capscrew SST	1
22	049060013	Wear Ring	1
23	049160001	Lower Seal (ceramic) std.	1
	049160011	Lower Seal (carbide) opt.	1
24	079930015	Volute w/Wearing Ring	1
25	005170071	Capscrew SST	3
26	009750031	Retainer Ring	1
27	107430002	Bearing Housing	1
28	009200011	Upper Seal	1
29	005680071	Capscrew	4
30	009950081	Washer	4
31	005170081	Capscrew	4
32	24407C223	Stator 1 hp 230/1 Φ /60 1150	1
	147152031	Stator 1 hp 200/1 Φ /60 1150	1
	24407C225	Stator 1 hp 230/460/3 Φ /60 1150	1
	24407C224	Stator 1 hp 200/3 Φ /60 1150	1
	24407C226	Stator 1 hp 575/3 Φ /60 1150	1
	24407C231	Stator 2 hp 230/1 Φ /60 1150	1
	147172031	Stator 2 hp 200/1 Φ /60 1150	1
	24407C233	Stator 2 hp 230/460/3 Φ /60 1150	1
	24407C232	Stator 2 hp 200/3 Φ /60 1150	1
	24407C234	Stator 2 hp 575/3 Φ /60 1150	1
	24407C215	Stator 2 hp 230/1 Φ /60 1750	1
	24407C217	Stator 2 hp 230/460/3 Φ /60 1750	1
	24407C216	Stator 2 hp 200/3 Φ /60 1750	1
	24407C218	Stator 2 hp 575/3 Φ /60 1750	1
	24407C200	Stator 3 hp 230/1 Φ /60 1750	1
	24407C202	Stator 3 hp 230/460/3 Φ /60 1750	1
	24407C201	Stator 3 hp 200/3 Φ /60 1750	1
	24407C203	Stator 3 hp 575/3 Φ /60 1750	1
	24407C204	Stator 5 hp 230/1 Φ /60 1750	1

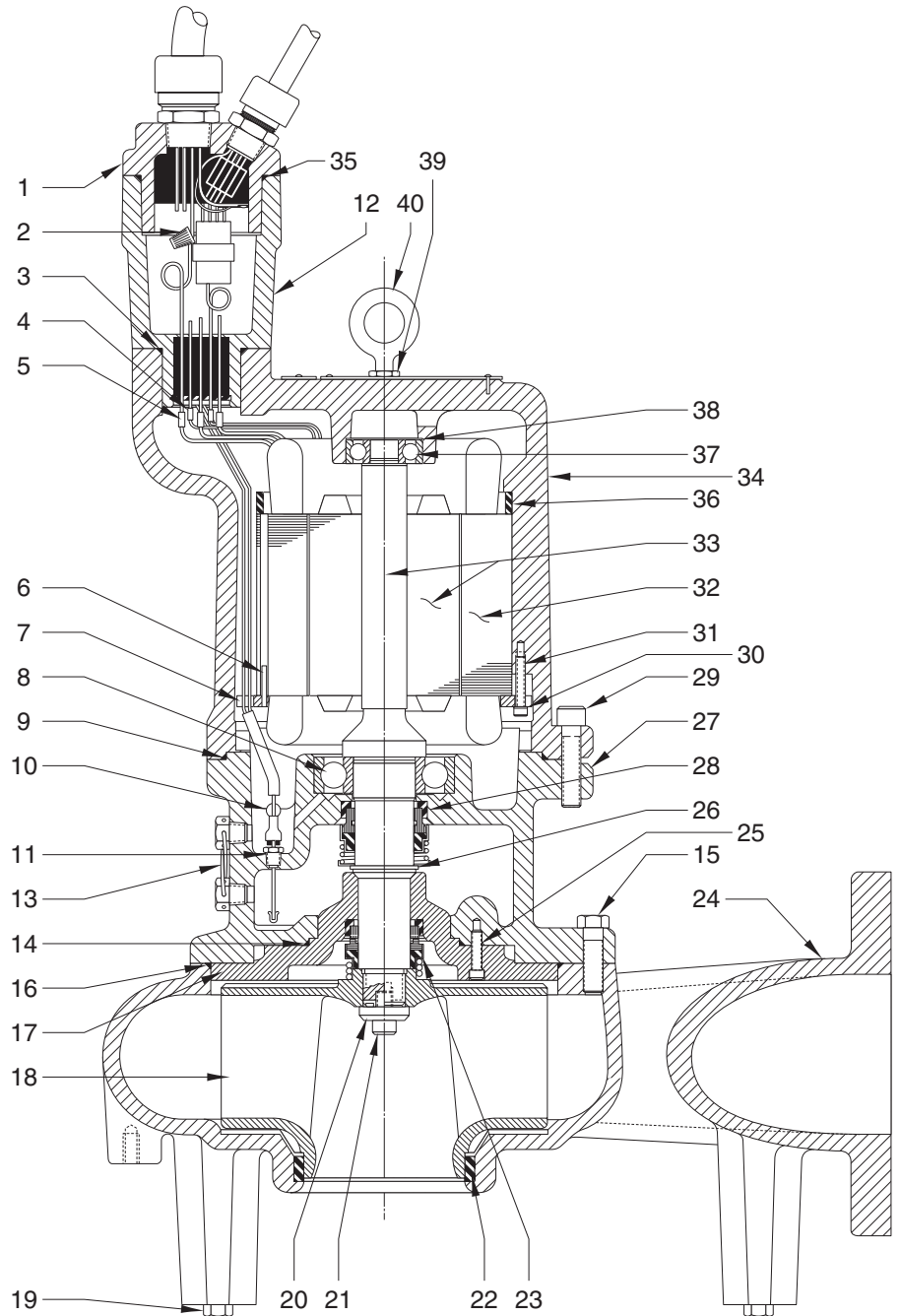

Item	Eng. No.	Description	Qty.
32	24407C206	Stator 5 hp 230/460/3 Φ /60 1750	1
	24407C205	Stator 5 hp 200/3 Φ /60 1750	1
	24407C207	Stator 5 hp 575/3 Φ /60 1750	1
	24407C209	Stator 7-1/2 hp 200/230/460/3 Φ /60 1750	1
	24407C210	Stator 7-1/2 hp 575/3 Φ /60 1750	1
33	077740145	Rotor & Shaft 1 hp 1 Φ 1150	1
	077730145	Rotor & Shaft 1 hp 3 Φ 1150	1
	013290175	Rotor & Shaft 2 hp 1 Φ 1150	1
	007400175	Rotor & Shaft 2 hp 3 Φ 1150	1
	007400175	Rotor & Shaft 2 hp 1 Φ 1750	1
	007410125	Rotor & Shaft 2 hp 3 Φ 1750	1
	013290175	Rotor & Shaft 3 hp 1 Φ 1750	1
	013290175	Rotor & Shaft 3-5 hp 3 Φ 1750	1
	013290175	Rotor & Shaft 7-1/2 hp 3 Φ 1750	1
34	107650032	Housing 1 hp 3 Φ 1150, 2 hp 3 Φ 1750	1
	107650022	Housing (all others)	1

Item	Eng. No.	Description	Qty.
35	008340131	O-Ring	1
36	007360011	Spacer 1 hp 3 Φ 1150, 2 hp 1 Φ /3 Φ 1750	1
	007360021	Spacer 1 hp 1 Φ 1150	1
37	000650211	Upper Bearing	1
38	000640031	Load Spring	1
39	010320021	Nut	2
40	21929A002	Eye Bolt	2

Note: Fill oil to above motor windings.

STANDARD LIMITED WARRANTY

Pentair Hydromatic® warrants its products against defects in material and workmanship for a period of 12 months from the date of shipment from Pentair Hydromatic or 18 months from the manufacturing date, whichever occurs first – provided that such products are used in compliance with the requirements of the Pentair Hydromatic catalog and technical manuals for use in pumping raw sewage, municipal wastewater or similar, abrasive-free, noncorrosive liquids.

During the warranty period and subject to the conditions set forth, Pentair Hydromatic, at its discretion, will repair or replace to the original user, the parts that prove defective in materials and workmanship. Pentair Hydromatic reserves the right to change or improve its products or any portions thereof without being obligated to provide such a change or improvement for prior sold and/or shipped units.

Start-up reports and electrical schematics may be required to support warranty claims. Submit at the time of start up through the Pentair Hydromatic website: <http://forms.pentairliterature.com/startupform/startupform.asp?type=h>. Warranty is effective only if Pentair Hydromatic authorized control panels are used. All seal fail and heat sensing devices must be hooked up, functional and monitored or this warranty will be void. Pentair Hydromatic will cover only the lower seal and labor thereof for all dual seal pumps. Under no circumstance will Pentair Hydromatic be responsible for the cost of field labor, travel expenses, rented equipment, removal/reinstallation costs or freight expenses to and from the factory or an authorized Pentair Hydromatic service facility.

This limited warranty will not apply: (a) to defects or malfunctions resulting from failure to properly install, operate or maintain the unit in accordance with the printed instructions provided; (b) to failures resulting from abuse, accident or negligence; (c) to normal maintenance services and parts used in connection with such service; (d) to units that are not installed in accordance with applicable local codes, ordinances and good trade practices; (e) if the unit is moved from its original installation location; (f) if unit is used for purposes other than for what it is designed and manufactured; (g) to any unit that has been repaired or altered by anyone other than Pentair Hydromatic or an authorized Pentair Hydromatic service provider; (h) to any unit that has been repaired using non factory specified/OEM parts.

Warranty Exclusions: PENTAIR HYDROMATIC MAKES NO EXPRESS OR IMPLIED WARRANTIES THAT EXTEND BEYOND THE DESCRIPTION ON THE FACE HEREOF. PENTAIR HYDROMATIC SPECIFICALLY DISCLAIMS THE IMPLIED WARRANTIES OF MERCHANTABILITY AND FITNESS FOR ANY PARTICULAR PURPOSE.

Liability Limitation: IN NO EVENT SHALL PENTAIR HYDROMATIC BE LIABLE OR RESPONSIBLE FOR CONSEQUENTIAL, INCIDENTAL OR SPECIAL DAMAGES RESULTING FROM OR RELATED IN ANY MANNER TO ANY PENTAIR HYDROMATIC PRODUCT OR PARTS THEREOF. PERSONAL INJURY AND/OR PROPERTY DAMAGE MAY RESULT FROM IMPROPER INSTALLATION. PENTAIR HYDROMATIC DISCLAIMS ALL LIABILITY, INCLUDING LIABILITY UNDER THIS WARRANTY, FOR IMPROPER INSTALLATION. PENTAIR HYDROMATIC RECOMMENDS INSTALLATION BY PROFESSIONALS.

Some states do not permit some or all of the above warranty limitations or the exclusion or limitation of incidental or consequential damages and therefore such limitations may not apply to you. No warranties or representations at any time made by any representatives of Pentair Hydromatic shall vary or expand the provision hereof.



HYDROMATIC®

740 EAST 9TH STREET
ASHLAND, OHIO, USA 44805
419-289-1144

490 PINEBUSH ROAD, UNIT #4
CAMBRIDGE, ONTARIO, CANADA N1T 0A5
800-363-PUMP

WWW.HYDROMATIC.COM