

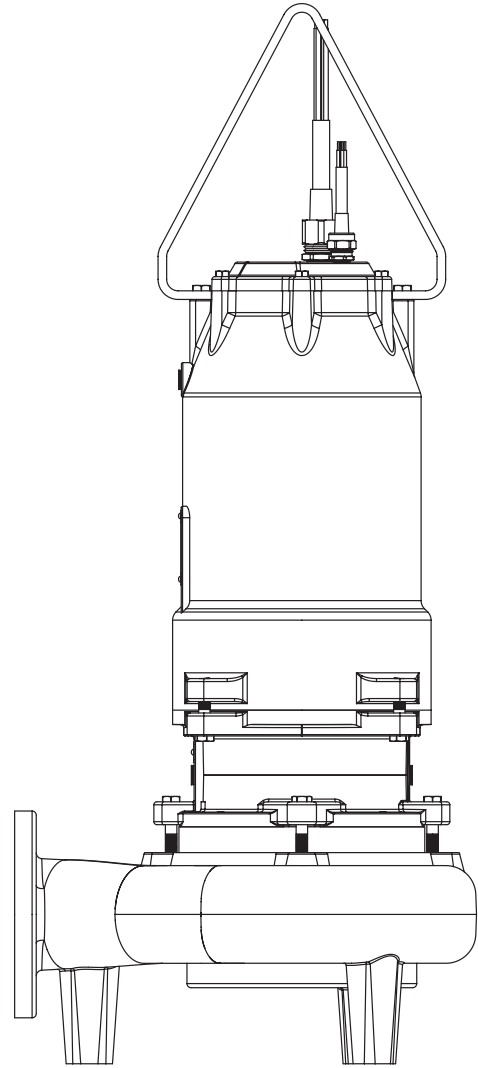

HYDROMATIC®



MODELS: C4S(X)P,
H3H(X)P, H4H(X)P, S4M(X)P, S4P(X)P,
S4HV(X)P and S4MV(X)P

(Class I, Division 1, Groups C & D): FM

SUBMERSIBLE SOLIDS HANDLING PUMP

INSTALLATION AND SERVICE MANUAL

For use with product built with Premium Efficient motor.

(Hazardous Location
Motor End)



Make sure this manual is provided to the owner of the equipment or to the responsible party who maintains the system.

General Information

Attention:

This manual contains important information for the safe use of this product. Read completely and do not throw away.

Reasonable care and safe methods should be practiced. Check local codes and requirements before installation.

Unpacking Pump:

When unpacking unit, check for damage. Claims for damage must be made at the receiving end through the delivery carrier. Damage cannot be processed from the factory.

WARNING: Before handling these pumps and controls, always disconnect the power first. Do not smoke or use sparkable electrical devices or flames in a septic (gaseous) or possible septic sump.

CALIFORNIA PROPOSITION 65

WARNING:

▲ WARNING This product and related accessories contain chemicals known to the State of California to cause cancer, birth defects or other reproductive harm.

Pumps in Storage or Not Operating:

Pumps with silicon/carbide seals must have impellers manually rotated (6 revolutions) after setting non-operational for 3 months or longer and prior to electrical start-up.

Pumps with tungsten carbide seals must have impellers manually rotated (6 revolutions) after setting non-operational for 3 weeks or longer and prior to electrical start-up.

Seal Failure Probes:

All hazardous location submersible pumps have two factory installed moisture detectors (seal failure probes). They are in a normally open series circuit in the seal chamber. Under normal operating conditions, the circuit remains open. If the lower seal leaks and moisture enters this chamber, the moisture would settle to the bottom of the chamber and will complete the circuit between the moisture detectors.

This circuit must be connected to a sensing unit and signaling device. This is supplied in a Hydromatic® built control panel.

NOTE: Failure to install such a device negates all warranties by Hydromatic.

Heat Sensors:

All motors in this family have heat sensors on or embedded in the motor winding to detect excessive heat. This prevents damage to the motor. If sensor trips due to excessive winding temperature, the starter in the panel breaks power to the pump. Once the sensor resets, the starter is automatically reset for FM for continued operation of the pump. This circuitry is supplied in a Hydromatic control panel.

The sensors are set to trip at 130°C.

NOTE: Failure to install such circuitry would negate FM approvals and all warranties by Hydromatic.

Power Cords:

The power cord and heat sensor seal failure cord are potted into the cord cap. The cords must not be spliced.

NOTE: Each cable has a green lead. This is the ground wire and must be grounded properly per NEC and/or local codes. Cords should be inspected for abnormal wear and replaced accordingly.

Overload Heaters:

If the Hydromatic electrical panel is not used, starters with 3 leg overload relay must be supplied on 3 phase pumps. Each leg is to have an identical heater sized in accordance with the nameplate amps on the motor housing. The amp draw on these submersible motors is slightly higher than a corresponding horsepower surface motor, so heaters must be sized by the nameplate rating.

Capacitor start single phase pumps have a run and start winding that draws different currents. To adequately protect these windings with the appropriate heaters, consult the factory.

NOTE: The red lead is always the start winding of a pump using single phase.

Pump Installation

Installing Sump Level Controls Float Controls:

In either simplex, duplex or triplex systems the lower or turn-off control is to be set to maintain a minimum level in the sump. This level shall be no more than 3-1/4" from the top of the motor housing down to the surface of the sewage.

The second or turn-on control is set above the lower turn-off control. The exact distance between the two floats must be a compromise between a frequent pumping cycle (10 starts per hour max.) to control septicity, solids and a slower cycle for energy economy. This distance should be determined by the engineer or consulting engineer, depending on the conditions of the application.

Installing Pump in Sump:

Before installing the pump in the sump, lay it on its side and rotate impeller.

Impeller may be slightly stuck due to factory test water. The impeller should turn freely.

Do not connect the power until after this test.

Clean all debris from sump and connect pump to piping. A check valve must be installed on each pump. A gate or plug valve in each pump discharge is highly recommended. This valve should be installed on the discharge side of the check valve so if necessary to service the check valve, the line pressure can be cut off. Single pump systems are sometimes installed without a check valve where it is desirable to self-drain the discharge line to prevent freezing. This can be done only with short discharge lines; otherwise water will return to the sump and cause short cycling of the pump.

Making Electrical Connections:

All electrical wiring must be in accordance with local codes, and only competent electricians should make the installations. Complete wiring diagrams are glued to the inside cover of the panel. All wires should be checked for grounds with an ohmmeter or Megger

after the connections are made. **THIS IS IMPORTANT, AS ONE GROUNDED WIRE CAN CAUSE CONSIDERABLE TROUBLE.**

IMPORTANT: If equipment is not properly wired and protected as recommended, the warranty is void.

Heat Sensors and Seal Failure Connections:

Be sure heat sensor wires are connected in series with the starter coil. Connections are provided on the terminal strip.

Pump Operations

Starting System:

1. Double check all wire connections.
2. Turn pumps to Off position on H-O-A switches.
3. Turn on breakers.
4. When using single phase pumps, make sure red pump lead is connected to capacitor circuit. Connect amprobe to pump power cord and turn pump on. The pump will show high amp draw momentarily, then as pump comes off start wirings, amps will drop to normal nameplate amps.

When using three phase pumps (230/460/575), turn the H-O-A switch to Hand position on one pump and notice operation. If

pump is noisy and vibrates, rotation is wrong. To change rotation, interchange any two line leads to pump. Do not interchange main incoming lines. Check rotation of all pumps in this same manner.

5. Now set both H-O-A switches to Auto position and allow water to rise in sump until one pump starts. Allow pump to operate until the level drops to turn-off point.
6. Allow sump level to rise to start other pump(s). Notice run lights in panel. Pumps should alternate on each successive cycle of operation.
7. Turn both H-O-A switches to Off position and allow sump to fill to the override control level(s).
8. Turn switches to Auto position, and pumps should start and operate together until level drops to turn-off point.
9. Repeat this operation and cycle several times before leaving the job.
10. Check voltage when pumps are operating and check the amp draw of each pump. Check amps on each wire as sometimes a high leg will exist. For excessive voltage on one leg, the electric utility company should be consulted.

Pump Maintenance

As the motors are oil filled, no lubrication or other maintenance is required.

If the heat sensor and seal failure are hooked up properly, no attention is necessary as long as the seal failure indicator light does not come on. To ensure continuity of the seal sensor leads, a test light is provided on intrinsically safe Hydromatic panels as standard equipment.

Pump should be checked every quarter for corrosion and wear.

Field Service on Hydromatic Hazardous Location Pumps:

If a Hydromatic hazardous location pump is used in a hazardous location, the pump must be returned to the factory for electrical and motor service. This will ensure the integrity of the hazardous location rating of the pump and comply with our warranty requirements.

The quick disconnect cords, upper and lower seal, volute and impeller components may be repaired or replaced by an authorized Hydromatic service facility without compromising the hazardous location rating to the pump.

Any time the seal is disturbed, it must be replaced.

Check the pump for proper rotation before returning to service.

**NUMBER OF CONDUCTORS REQUIRED BETWEEN CONTROL PANEL AND NEMA 4 JUNCTION BOX
POWER LINES AND CONTROL WIRES CAN BE CARRIED IN CONDUIT OR CAN BE UNDERGROUND BURIED CABLE**

System Type	Number of Control Wires	Number of Power Lines	Number of Ground Wires #8	HEAT SENSOR & SEAL FAILURE	
				Number of Sensor Wires	Number of Ground Wires
Simplex	4	3	1	3	1
Simplex with Alarm	6	3	1	3	1
Duplex	6	6	2	6	2
Duplex with Alarm	8	6	2	6	2

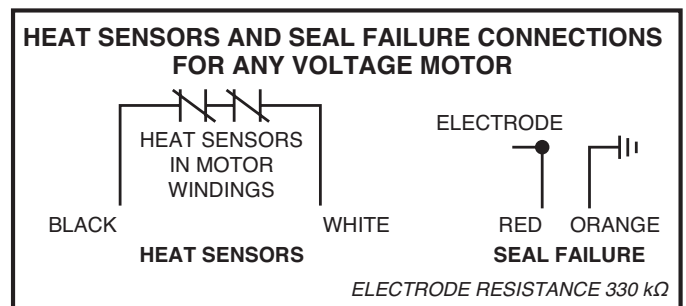
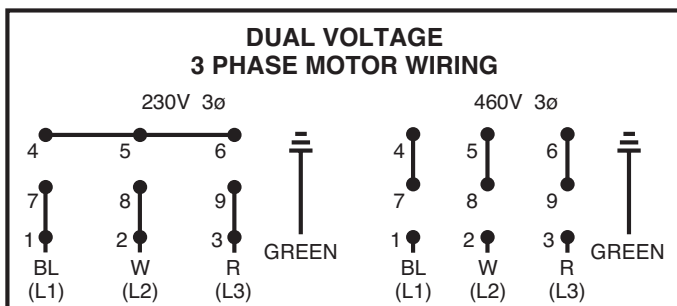

Adjust Cutter Clearance on Chopper Pump

WARNING: Disconnect power before adjusting chopper clearance; always keep fingers and hands away from chopper parts.

1. First install the chopper plate (Item D) into the volute. It may be helpful to install 1/2-20 studs into the chopper plate to line up the holes with the corresponding volute holes. You may have to tap the plate all the way down with a rubber hammer.

2. Remove the studs and replace with four 1/2-20 x 1 (Item A) in long socket head screws (part no 005680091) from beneath the volute, do not tighten.
3. Install motor with impeller mounted, tighten motor housing bolts to the volute
4. Install the chopper retainer ring (Item B) and tighten the four 3/8-16 x 1" long (Item C) socket head cap screws (part no 06106A028) to force the chopper plate up against the impeller and chopper blade
5. Next back off these 3/8-16 (Item C) bolts one quarter of a turn. This should give you .015 clearances.

6. Tighten the outer four 1/2 -20 screws (Item A) to 75-85 Ft-lbs.
7. Measure the clearance with a feeler gage it should be between .010 and .015.
8. Spin impeller with a hex wrench on the Impeller hub screw or use a wooden pry bar to spin impeller to make sure there is no rub.
9. If you hear or feel a rub readjust the clearance by loosening the inner 3/8-16 screws evenly and tightening the 1/2- 20 screws.

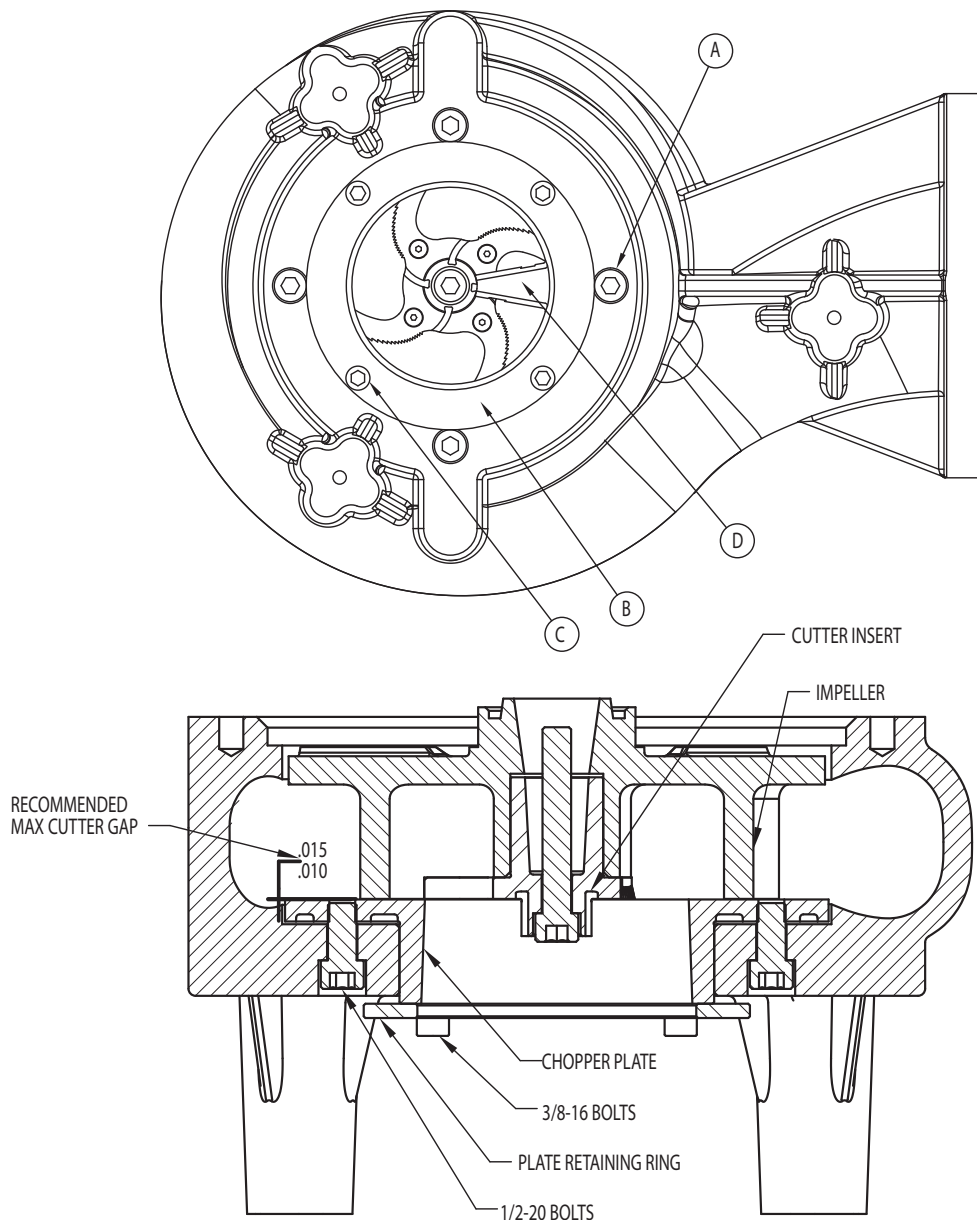

Pump Troubleshooting

Below is a list of common problems and the probable causes:

Pump will not start.

1. No power to the motor. Check for blown fuse or open circuit breaker.
2. Selector switch may be in the Off position.
3. Control circuit transformer fuse may be blown.
4. Overload heater on starter may be tripped. Push to reset.

Pump will not start and overload heaters trip.

1. Turn off power and check motor leads with Megger or ohmmeter for possible ground.
2. Check resistance of motor windings. All 3 phases should show the same reading.
3. If no grounds exist and the motor windings check OK, remove pump from sump and check for clogged or blocked impeller.

Pump operates with selector switch in Hand position but will not operate in Auto position.

1. This indicates trouble in the float level control or the alternator relay.
2. Check control panel for trouble.

Pump runs but will not shut off.

1. Pump may be air locked. Turn pump off and let set for several minutes, then restart.
2. Lower float control may be hung-up in the closed position. Check in sump to be sure control is free.
3. Selector switch may be in the Hand position.

Pump does not deliver proper capacity.

1. Discharge gate valve may be partially closed or partially clogged.
2. Check valve may be partially clogged. Raise level up and down to clear.
3. Pump may be running in wrong direction. Low speed pumps can operate in reverse direction without much noise or vibration.
4. Discharge head may be too high. Check total head with gauge when pump is operating. Total head is discharge gauge pressure converted to feet plus vertical height from water level in sump to center line of pressure gauge in discharge line. Gauge should be installed on pump side of all valves. Multiply gauge pressure in pounds by 2.31 to get

head in feet.

5. If pump has been in service for some time and capacity falls off, remove pump and check for wear or clogged impeller.

Motor stops and then restarts after short period but overload heaters in starter do not trip.

1. This indicates heat sensors in the motor are tripping due to excessive heat. Impeller may be partially clogged giving a sustained overload but not high enough to trip overload heater switch.
2. Motor may be operating out of liquid due to a failed level control.
3. Pump may be operating on a short cycle due to sump being too small or from water returning to sump due to a leaking check valve.

C4S(X)P, H3H(X)P, H4H(X)P, S4M(X)P, S4P(X)P, S4HV(X)P and S4MV(X)P Parts List

For use with product built with Premium Efficient motor.

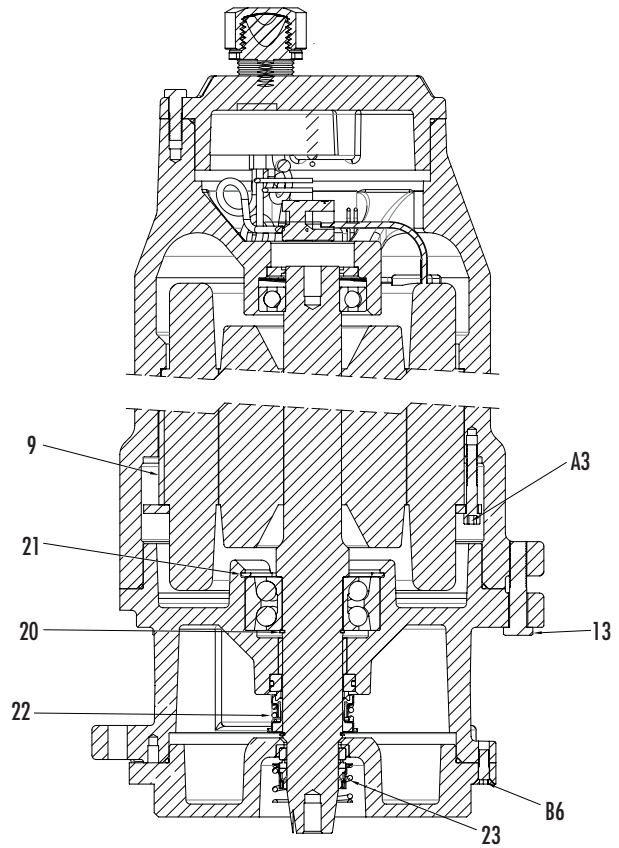
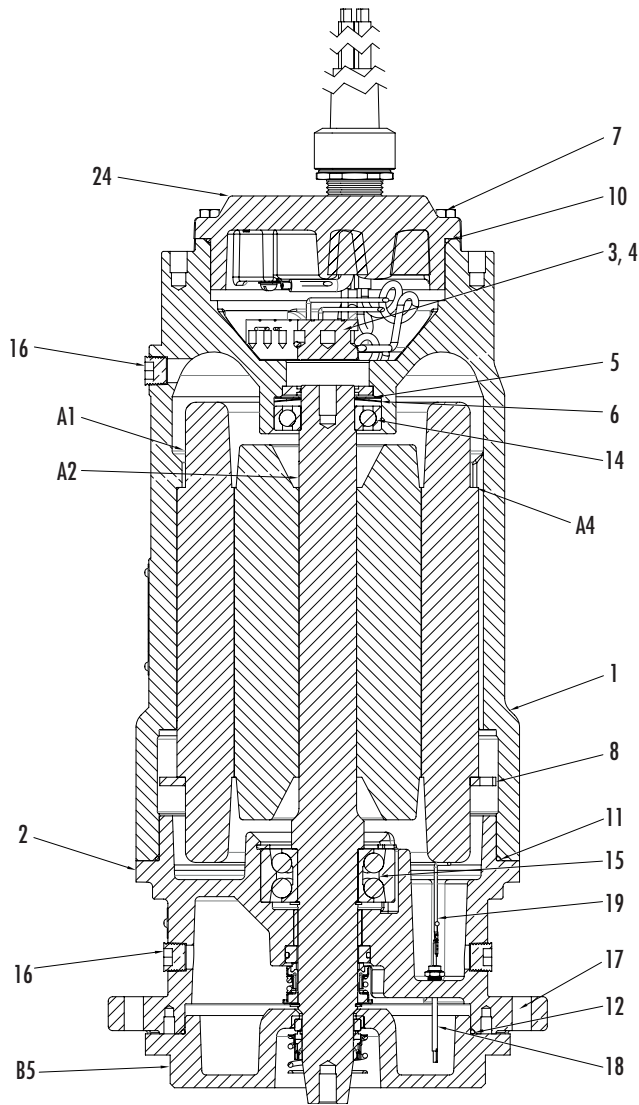

Ref. No.	Part No.	Part Description	Qty.
1	28010D000	MOTOR HOUSING	1
2	27818D010	BEARING HOUSING	1
3	27882A009	TERMINAL BLOCK	1
4	06106A069	SCREW (TERMINAL BLOCK)	2
5	110650033	SCREEN	1
6	19331A007	WASHER SPRING (THRUST)	1
7	19101A017	CAP SCREW (CORD CAP)	6
8	026032103	STATOR RING	1
9	05818A090	KEY SQ. 5/32	1
10	001500191	O-RING (CORD CAP)	1
11	05876A135	O-RING (MOTOR HOUSING)	1
12	05876A121	O-RING (SEAL PLATE)	1
13	19103A048	SCREW CAP 1/2-13 x 2.5 LG	4
14	000650111	BALL BEARING UPPER	1

Ref. No.	Part No.	Part Description	Qty.
15	071670181	DOUBLE ROW BALL BEARING LOWER	1
16	009240101	PIPE PLUG 1/2 SOCKET HEAD BRASS	3
17	19103A048	CAPSCREW – S4M(X)P, S4MV(X)P, S4HV(X)P	4
	19103A060	CAPSCREW – S4P(X)P, H3H(X)P, H4H(X)P	4
18	109010011	SEAL FAILURE PROBE	2
19	109000025	SENSOR WIRES	1
20	12558A017	RETAINING RING EXTERNAL	1
21	009740031	RETAINING RING INTERNAL	1
22	110491001	UPPER SEAL	1
23	009201001	LOWER SEAL	1
24	152880315	CORD CAP ASSEMBLY – 10-4 SOOW	1
	152880325	CORD CAP ASSEMBLY – 8-4 W	1
	152880335	CORD CAP ASSEMBLY – 6-4 W	1

Hydraulic End Parts List

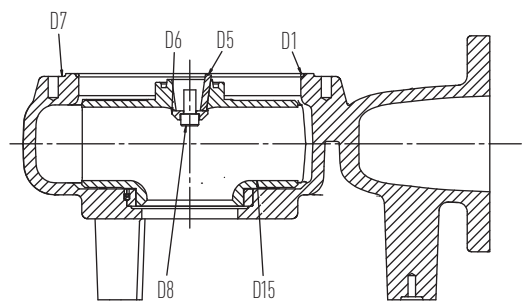

S4MXP

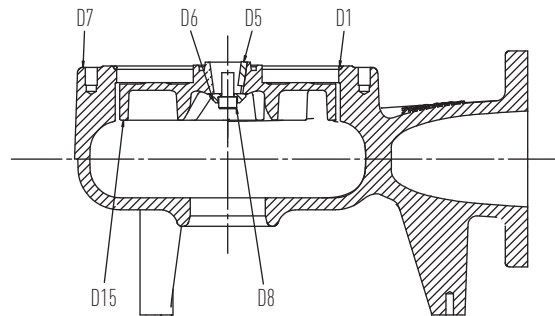

S4MVXP

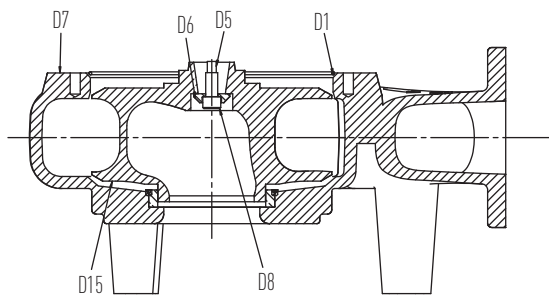

S4PXP

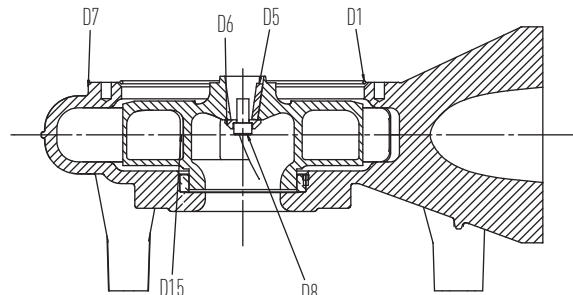

H3HXP

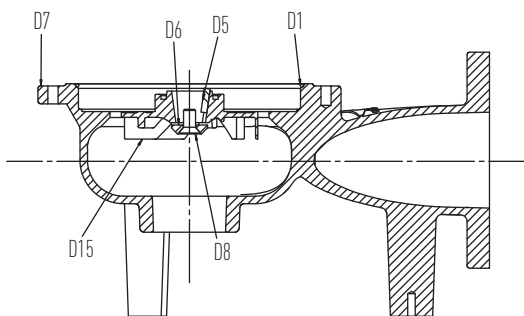

S4HVXP

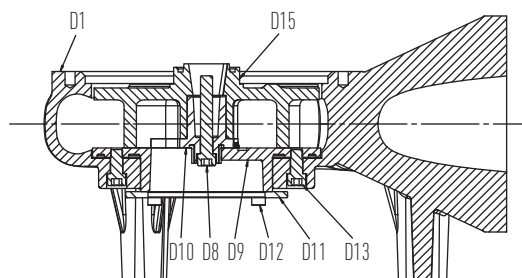

C4SXP

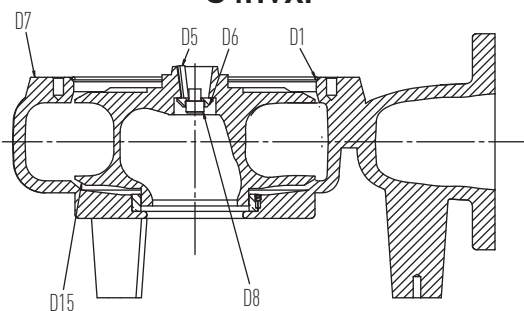

H4HXP

Item No.	Description	S4M(X)P	S4MV(X)P	S4HV(X)P	S4P(X)P	H3H(X)P	H4H(X)P	C4S(X)P
D1	O-RING	001500581	001500581	001500581	05876A136	05876A136	05876A136	05876A136
D5	IMPELLER KEY	083460033	083460011	083460011	083460033	083460033	083460033	083460033
D6	WASHER – IMPELLER	080230001	080230001	080230011	080230001	080230001	080230001	N/A
D7	VOLUTE	070680015	070800002	082120002	137210015	151540015	151470015	153300002
D8	IMP BOLT	005680021	005680021	029210041	005680021	005680021	005680021	005680191
D9	CHOPPER PLATE	N/A	N/A	N/A	N/A	N/A	N/A	153340002
D10	CHOPPER BLADE	N/A	N/A	N/A	N/A	N/A	N/A	153320002
D11	RETAINER PLATE	N/A	N/A	N/A	N/A	N/A	N/A	153330001
D12	SCREW-CAP (RETAINER)	N/A	N/A	N/A	N/A	N/A	N/A	06106A028
D13	SCREW-CAP (CHOPPER PLATE)	N/A	N/A	N/A	N/A	N/A	N/A	005680021
D14	SCREW - FLAT HEAD SOCKET	N/A	N/A	N/A	N/A	N/A	N/A	07597A037
D15	IMPELLER	070710012	070810002	082130052	137220012	151465002	151465002	153310002

Motor Parts Group

Item	2-Pole 3450 RPM	10 – 15 hp 208-230/3/60	10 – 15 hp 460/3/60	10 – 15 hp 575/3/60	7.5 hp 208-230/3/60	7.5 hp 460/3/60	7.5 hp 575/3/60
A1	STATOR	27889D003	27889D003	27889D603	27887D003	27887D003	27887D603
A2	ROTOR/SHAFT ASSEMBLY	27887D011	27887D011	27887D011	27887D011	27887D011	27887D011
A3	BOLT – STATOR (4)	001780051	001780051	001780051	001780051	001780051	001780051
A4	SPACER	007362141	007362141	007362141	007362141	007362141	007362141
	CONNECTOR	–	12672A001	–	–	12672A001	–

Item	4-Pole 1750 RPM	10 – 15 hp 208-230/3/60	10 – 15 hp 460/3/60	10 – 15 hp 575/3/60	5 – 7.5 hp 208-230/1/60	5 – 7.5 hp 208-230/3/60	5 – 7.5 hp 460/3/60	5 – 7.5 hp 575/3/60
A1	STATOR	27886D003	27886D003	27886D603	27885D001	27884D003	27884D003	27884D603
A2	ROTOR/SHAFT ASSEMBLY	27886D011	27886D011	27886D011	27885D011	27884D011	27884D011	27884D011
A3	BOLT – STATOR (4)	06106A070	06106A070	06106A070	001780051	001780041	001780041	001780041
A4	SPACER	–	–	–	007362141	007362141	007362141	007362141
	CONNECTOR	–	12672A001	–	–	–	12672A001	–

Item	6-Pole 1150 RPM	3 – 5 hp 208-230/3/60	3 – 5 hp 460/3/60	3 – 5 hp 575/3/60
A1	STATOR	27883D003	27883D003	27883D603
A2	ROTOR/SHAFT ASSEMBLY	27883D011	27883D011	27883D011
A3	BOLT – STATOR (4)	001780051	001780051	001780051
A4	SPACER	007362141	007362141	007362141
	CONNECTOR	–	12672A001	–

Impeller Parts List

H3H(X)P

Description	Part No.	hp	Voltage/ph	Cord	Trim	Impeller
1750 RPM						
H3H(X)P500BC	528040007	5	208/1	8-4	7.50	151465102
H3H(X)P500CC	528040017	5	230/1	8-4	7.50	151465102
H3H(X)P500DC	528040027	5	208/3	10-4	7.50	151465102
H3H(X)P500EC	528040037	5	230/3	10-4	7.50	151465102
H3H(X)P500FC	528040047	5	460/3	10-4	7.50	151465102
H3H(X)P500GC	528040057	5	575/3	10-4	7.50	151465102
H3H(X)P750CC	528040067	7.5	230/1	8-4	8.00	151465082
H3H(X)P750DC	528040077	7.5	208/3	8-4	8.00	151465082
H3H(X)P750EC	528040087	7.5	230/3	8-4	8.00	151465082
H3H(X)P750FC	528040097	7.5	460/3	10-4	8.00	151465082
H3H(X)P750GC	528040107	7.5	575/3	10-4	8.00	151465082
H3H(X)P1000DC	528040117	10	208/3	8-4	8.75	151465052
H3H(X)P1000EC	528040127	10	230/3	8-4	8.75	151465052
H3H(X)P1000FC	528040137	10	460/3	10-4	8.75	151465052
H3H(X)P1000GC	528040147	10	575/3	10-4	8.75	151465052
H3H(X)P1500DC	528040157	15	208/3	8-4	10.00	151465002
H3H(X)P1500EC	528040167	15	230/3	8-4	10.00	151465002
H3H(X)P1500FC	528040177	15	460/3	8-4	10.00	151465002
H3H(X)P1500GC	528040187	15	575/3	10-4	10.00	151465002

H4H(X)P

Description	Part No.	hp	Voltage/ph	Cord	Trim	Impeller
1750 RPM						
H4H(X)P500BC	528050007	5	208/1	8-4	7.50	151465102
H4H(X)P500CC	528050017	5	230/1	8-4	7.50	151465102
H4H(X)P500DC	528050027	5	208/3	10-4	7.50	151465102
H4H(X)P500EC	528050037	5	230/3	10-4	7.50	151465102
H4H(X)P500FC	528050047	5	460/3	10-4	7.50	151465102
H4H(X)P500GC	528050057	5	575/3	10-4	7.50	151465102
H4H(X)P750CC	528050067	7.5	230/1	8-4	8.00	151465082
H4H(X)P750DC	528050077	7.5	208/3	8-4	8.00	151465082
H4H(X)P750EC	528050087	7.5	230/3	8-4	8.00	151465082
H4H(X)P750FC	528050097	7.5	460/3	10-4	8.00	151465082
H4H(X)P750GC	528050107	7.5	575/3	10-4	8.00	151465082
H4H(X)P1000DC	528050117	10	208/3	8-4	8.75	151465052
H4H(X)P1000EC	528050127	10	230/3	8-4	8.75	151465052
H4H(X)P1000FC	528050137	10	460/3	10-4	8.75	151465052
H4H(X)P1000GC	528050147	10	575/3	10-4	8.75	151465052
H4H(X)P1500DC	528050157	15	208/3	8-4	10.00	151465002
H4H(X)P1500EC	528050167	15	230/3	8-4	10.00	151465002
H4H(X)P1500FC	528050177	15	460/3	8-4	10.00	151465002
H4H(X)P1500GC	528050187	15	575/3	10-4	10.00	151465002

Impeller Parts List

S4M(X)P

Description	Part No.	hp	Voltage/ph	Cord	Trim	Impeller
1750 RPM						
S4M(X)P500BC	528010177	5	208/1	8-4	6.88	070710152
S4M(X)P500CC	528010187	5	230/1	8-4	6.88	070710152
S4M(X)P500DC	528010127	5	208/3	10-4	6.88	070710152
S4M(X)P500EC	528010137	5	230/3	10-4	6.88	070710152
S4M(X)P500FC	528010147	5	460/3	10-4	6.88	070710152
S4M(X)P500GC	528010157	5	575/3	10-4	6.88	070710152
S4M(X)P750CC	528010167	7.5	230/1	8-4	7.5	070710072
S4M(X)P750DC	528010087	7.5	208/3	8-4	7.5	070710072
S4M(X)P750EC	528010097	7.5	230/3	8-4	7.5	070710072
S4M(X)P750FC	528010107	7.5	460/3	10-4	7.5	070710072
S4M(X)P750GC	528010117	7.5	575/3	10-4	7.5	070710072
S4M(X)P1000DC	528010047	10	208/3	8-4	8.00	070710052
S4M(X)P1000EC	528010057	10	230/3	8-4	8.00	070710052
S4M(X)P1000FC	528010067	10	460/3	10-4	8.00	070710052
S4M(X)P1000GC	528010077	10	575/3	10-4	8.00	070710052
S4M(X)P1500DC	528010007	15	208/3	8-4	9.00	070710012
S4M(X)P1500EC	528010017	15	230/3	8-4	9.00	070710012
S4M(X)P1500FC	528010027	15	460/3	8-4	9.00	070710012
S4M(X)P1500GC	528010037	15	575/3	10-4	9.00	070710012
1150 RPM						
S4M(X)P300DB	528010237	3	208/3	10-4	8.00	070710052
S4M(X)P300EB	528010247	3	230/3	10-4	8.00	070710052
S4M(X)P300FB	528010257	3	460/3	10-4	8.00	070710052
S4M(X)P300GB	528010267	3	575/3	10-4	8.00	070710052
S4M(X)P500DB	528010197	5	208/3	10-4	9.00	070710012
S4M(X)P500EB	528010207	5	230/3	10-4	9.00	070710012
S4M(X)P500FB	528010217	5	460/3	10-4	9.00	070710012
S4M(X)P500GB	528010227	5	575/3	10-4	9.00	070710012

S4MV(X)P

Description	Part No.	hp	Voltage/ph	Cord	Trim	Impeller
1750 RPM						
S4MV(X)P500BC	528020007	5	208/1	8-4	6.75	070810082
S4MV(X)P500CC	528020017	5	230/1	8-4	6.75	070810082
S4MV(X)P500DC	528020027	5	208/3	10-4	6.75	070810082
S4MV(X)P500EC	528020037	5	230/3	10-4	6.75	070810082
S4MV(X)P500FC	528020047	5	460/3	10-4	6.75	070810082
S4MV(X)P500GC	528020057	5	575/3	10-4	6.75	070810082
S4MV(X)P750CC	528020067	7.5	230/1	8-4	8.00	070810022
S4MV(X)P750DC	528020077	7.5	208/3	8-4	8.00	070810022
S4MV(X)P750EC	528020087	7.5	230/3	8-4	8.00	070810022
S4MV(X)P750FC	528020097	7.5	460/3	10-4	8.00	070810022
S4MV(X)P750GC	528020107	7.5	575/3	10-4	8.00	070810022
S4MV(X)P1000DC	528020117	10	208/3	8-4	8.75	070810092
S4MV(X)P1000EC	528020127	10	230/3	8-4	8.75	070810092
S4MV(X)P1000FC	528020137	10	460/3	10-4	8.75	070810092
S4MV(X)P1000GC	528020147	10	575/3	10-4	8.75	070810092
S4MV(X)P1500DC	528020157	15	208/3	8-4	9.00	070810002
S4MV(X)P1500EC	528020167	15	230/3	8-4	9.00	070810002
S4MV(X)P1500FC	528020177	15	460/3	8-4	9.00	070810002
S4MV(X)P1500GC	528020187	15	575/3	10-4	9.00	070810002
1150 RPM						
S4MV(X)P300DB	528020197	3	208/3	10-4	8.50	070810012
S4MV(X)P300EB	528020207	3	230/3	10-4	8.50	070810012
S4MV(X)P300FB	528020217	3	460/3	10-4	8.50	070810012
S4MV(X)P300GB	528020227	3	575/3	10-4	8.50	070810012
S4MV(X)P500DB	528020237	5	208/3	10-4	9.00	070810002
S4MV(X)P500EB	528020247	5	230/3	10-4	9.00	070810002
S4MV(X)P500FB	528020257	5	460/3	10-4	9.00	070810002
S4MV(X)P500GB	528020267	5	575/3	10-4	9.00	070810002

S4HV(X)P

Description	Part No.	hp	Voltage/ph	Cord	Trim	Impeller
3450 RPM						
S4HV(X)P750DD	528000087	7.5	208/3	8-4	4.63	082130172
S4HV(X)P750ED	528000097	7.5	230/3	8-4	4.63	082130172
S4HV(X)P750FD	528000107	7.5	460/3	10-4	4.63	082130172
S4HV(X)P750GD	528000117	7.5	575/3	10-4	4.63	082130172
S4HV(X)P1000DD	528000047	10	208/3	8-4	5	082130042
S4HV(X)P1000ED	528000057	10	230/3	8-4	5	082130042
S4HV(X)P1000FD	528000067	10	460/3	10-4	5	082130042
S4HV(X)P1000GD	528000077	10	575/3	10-4	5	082130042
S4HV(X)P1500DD	528000007	15	208/3	8-4	5.63	082130182
S4HV(X)P1500ED	528000017	15	230/3	8-4	5.63	082130182
S4HV(X)P1500FD	528000027	15	460/3	10-4	5.63	082130182
S4HV(X)P1500GD	528000037	15	575/3	10-4	5.63	082130182

S4P(X)P

Description	Part No.	hp	Voltage/ph	Cord	Trim	Impeller
1750 RPM						
S4P(X)P500BC	528030007	5	208/1	8-4	7.50	137226112
S4P(X)P500CC	528030017	5	230/1	8-4	7.50	137226112
S4P(X)P500DC	528030027	5	208/3	10-4	7.50	137226112
S4P(X)P500EC	528030037	5	230/3	10-4	7.50	137226112
S4P(X)P500FC	528030047	5	460/3	10-4	7.50	137226112
S4P(X)P500GC	528030057	5	575/3	10-4	7.50	137226112
S4P(X)P750CC	528030067	7.5	230/1	8-4	8.25	137226082
S4P(X)P750DC	528030077	7.5	208/3	8-4	8.25	137226082
S4P(X)P750EC	528030087	7.5	230/3	8-4	8.25	137226082
S4P(X)P750FC	528030097	7.5	460/3	10-4	8.25	137226082
S4P(X)P750GC	528030107	7.5	575/3	10-4	8.25	137226082
S4P(X)P1000DC	528030117	10	208/3	8-4	9.25	137226042
S4P(X)P1000EC	528030127	10	230/3	8-4	9.25	137226042
S4P(X)P1000FC	528030137	10	460/3	10-4	9.25	137226042
S4P(X)P1000GC	528030147	10	575/3	10-4	9.25	137226042
S4P(X)P1500DC	528030157	15	208/3	8-4	10.00	137226012
S4P(X)P1500EC	528030167	15	230/3	8-4	10.00	137226012
S4P(X)P1500FC	528030177	15	460/3	8-4	10.00	137226012
S4P(X)P1500GC	528030187	15	575/3	10-4	10.00	137226012

C4S(X)P

Description	Part No.	hp	Voltage/ph	Cord	Trim	Impeller
1750 RPM						
C4S(X)P750CC	528280067	7.5	230/1	8-4	7.00	153310192
C4S(X)P750DC	528280077	7.5	208/3	8-4	7.00	153310192
C4S(X)P750EC	528280087	7.5	230/3	8-4	7.00	153310192
C4S(X)P750FC	528280097	7.5	460/3	10-4	7.00	153310192
C4S(X)P750GC	528280107	7.5	575/3	10-4	7.00	153310192
C4S(X)P1000DC	528280117	10	208/3	8-4	7.75	153310132
C4S(X)P1000EC	528280127	10	230/3	8-4	7.75	153310132
C4S(X)P1000FC	528280137	10	460/3	10-4	7.75	153310132
C4S(X)P1000GC	528280147	10	575/3	10-4	7.75	153310132
C4S(X)P1500DC	528280157	15	208/3	8-4	8.75	153310052
C4S(X)P1500EC	528280167	15	230/3	8-4	8.75	153310052
C4S(X)P1500FC	528280177	15	460/3	8-4	8.75	153310052
C4S(X)P1500GC	528280187	15	575/3	10-4	8.75	153310052
1150 RPM						
C4S(X)P300DB	528280197	3	208/3	10-4	7.75	153310132
C4S(X)P300EB	528280207	3	230/3	10-4	7.75	153310132
C4S(X)P300FB	528280217	3	460/3	10-4	7.75	153310132
C4S(X)P300GB	528280227	3	575/3	10-4	7.75	153310132
C4S(X)P500DB	528280237	5	208/3	10-4	8.75	153310052
C4S(X)P500EB	528280247	5	230/3	10-4	8.75	153310052
C4S(X)P500FB	528280257	5	460/3	10-4	8.75	153310052
C4S(X)P500GB	528280267	5	575/3	10-4	8.75	153310052

STANDARD LIMITED WARRANTY

Pentair Hydromatic® warrants its products against defects in material and workmanship for a period of 12 months from the date of shipment from Pentair Hydromatic or 18 months from the manufacturing date, whichever occurs first – provided that such products are used in compliance with the requirements of the Pentair Hydromatic catalog and technical manuals for use in pumping raw sewage, municipal wastewater or similar, abrasive-free, noncorrosive liquids.

During the warranty period and subject to the conditions set forth, Pentair Hydromatic, at its discretion, will repair or replace to the original user, the parts that prove defective in materials and workmanship. Pentair Hydromatic reserves the right to change or improve its products or any portions thereof without being obligated to provide such a change or improvement for prior sold and/or shipped units.

Start-up reports and electrical schematics may be required to support warranty claims. Submit at the time of start up through the Pentair Hydromatic website: <http://forms.pentairliterature.com/startupform/startupform.asp?type=h>. Warranty is effective only if Pentair Hydromatic authorized control panels are used. All seal fail and heat sensing devices must be hooked up, functional and monitored or this warranty will be void. Pentair Hydromatic will cover only the lower seal and labor thereof for all dual seal pumps. Under no circumstance will Pentair Hydromatic be responsible for the cost of field labor, travel expenses, rented equipment, removal/reinstallation costs or freight expenses to and from the factory or an authorized Pentair Hydromatic service facility.

This limited warranty will not apply: (a) to defects or malfunctions resulting from failure to properly install, operate or maintain the unit in accordance with the printed instructions provided; (b) to failures resulting from abuse, accident or negligence; (c) to normal maintenance services and parts used in connection with such service; (d) to units that are not installed in accordance with applicable local codes, ordinances and good trade practices; (e) if the unit is moved from its original installation location; (f) if unit is used for purposes other than for what it is designed and manufactured; (g) to any unit that has been repaired or altered by anyone other than Pentair Hydromatic or an authorized Pentair Hydromatic service provider; (h) to any unit that has been repaired using non factory specified/OEM parts.

Warranty Exclusions: PENTAIR HYDROMATIC MAKES NO EXPRESS OR IMPLIED WARRANTIES THAT EXTEND BEYOND THE DESCRIPTION ON THE FACE HEREOF. PENTAIR HYDROMATIC SPECIFICALLY DISCLAIMS THE IMPLIED WARRANTIES OF MERCHANTABILITY AND FITNESS FOR ANY PARTICULAR PURPOSE.

Liability Limitation: IN NO EVENT SHALL PENTAIR HYDROMATIC BE LIABLE OR RESPONSIBLE FOR CONSEQUENTIAL, INCIDENTAL OR SPECIAL DAMAGES RESULTING FROM OR RELATED IN ANY MANNER TO ANY PENTAIR HYDROMATIC PRODUCT OR PARTS THEREOF. PERSONAL INJURY AND/OR PROPERTY DAMAGE MAY RESULT FROM IMPROPER INSTALLATION. PENTAIR HYDROMATIC DISCLAIMS ALL LIABILITY, INCLUDING LIABILITY UNDER THIS WARRANTY, FOR IMPROPER INSTALLATION. PENTAIR HYDROMATIC RECOMMENDS INSTALLATION BY PROFESSIONALS.

Some states do not permit some or all of the above warranty limitations or the exclusion or limitation of incidental or consequential damages and therefore such limitations may not apply to you. No warranties or representations at any time made by any representatives of Pentair Hydromatic shall vary or expand the provision hereof.



HYDROMATIC®

1101 MYERS PARKWAY
ASHLAND, OHIO, USA 44805
855-274-8947

490 PINEBUSH ROAD, UNIT #4
CAMBRIDGE, ONTARIO, CANADA N1T 0A5
800-363-PUMP

WWW.HYDROMATIC.COM