

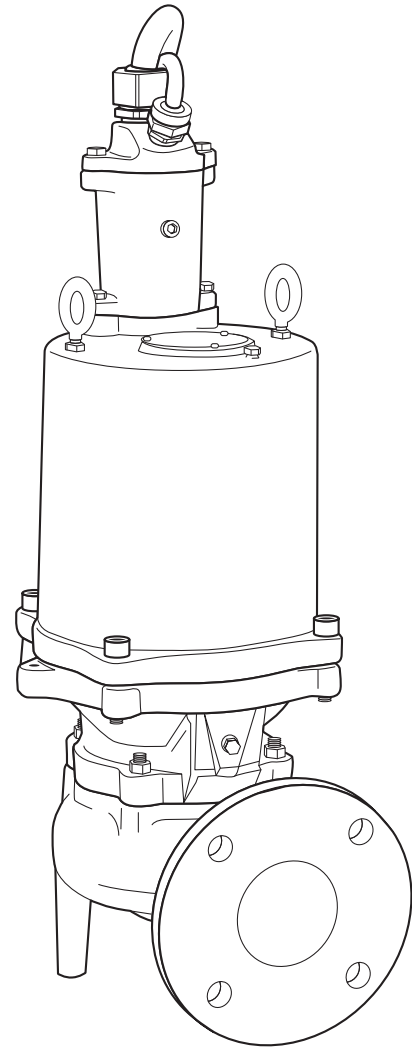

HYDROMATIC®



S3HRC
Shown

MODELS S3HRC, S3HVX*,
S4NRC and S4NVX*

*For use in Hazardous Locations Class I, Division 1, Groups C & D

SUBMERSIBLE SEWAGE PUMP RECESSED IMPELLER

INSTALLATION AND SERVICE MANUAL



NOTE! To the installer: Please make sure you provide this manual to the owner of the equipment or to the responsible party who maintains the system.

General Information

Attention:

This manual contains important information for the safe use of this product. Read this manual completely before using this product and refer to it often for continued safe product use. Reasonable care and safe methods should be practiced. Check local codes and requirements before installation.

Unpacking Pump:

When unpacking unit, check for concealed damage. Claims for damage must be made at the receiving end through the delivery carrier. Damage cannot be processed from the factory.

Safety warnings

DANGER: Risk of electrical shock or electrocution. May result in serious injury, death or fire hazard. Installer must disconnect all electrical sources prior to installation, handling or servicing. Only qualified personnel may install this system. NFPA 70/National Electric Code (NEC) or local codes must be followed. System must be properly grounded according to NEC. Do not lift pump by power cord.

DANGER: Biohazard risk. Once wastewater source has been connected to system, biohazard risk exists. Installer(s) and/or service personnel must use proper personal protective equipment and follow handling procedures per OSHA 29 CFR 1910.1030 when handling equipment after wastewater source has been connected to system.

DANGER: Risk of asphyxiation. Installer(s) and/or service personnel must use proper personal protective equipment and follow OSHA 29 CFR 1910.146 or OSHA 29 CFR 1926. Pump may be installed in a location classified as a confined space.

DANGER: Cutting risk. Risk of serious cutting or amputation exists. Disconnect all power sources prior to servicing the pump. Pump may start without warning.

Pumps are not approved for use in swimming pools, recreational water installations, decorative fountains or any installation where human contact with the pumped fluid is common.

CALIFORNIA PROPOSITION 65

WARNING:

▲ WARNING This product and related accessories contain chemicals known to the State of California to cause cancer, birth defects or other reproductive harm.

Pumps in Storage or Not Operating:

Pumps with carbon ceramic seals must have impellers manually rotated (six revolutions) after sitting non-operational

for three months or longer and prior to electrical start-up.

Pumps with tungsten carbide seals must have impellers manually rotated (six revolutions) after sitting non-operational for three weeks or longer and prior to electrical start-up.

Seal Failure:

An electrode is installed in the seal chamber so if any water enters the chamber through the first seal, the electrode will be energized and a signal will be transmitted to the sensing unit at ground surface causing an alarm function to energize.

In operation the seal failure unit indicates only that there is some water in the seal chamber. The pump will continue to operate without damage, but the seal should be checked immediately after failure is indicated.

NOTE: Failure to install such a device negates all warranties by Hydromatic®.

Seal Failure Probes:

All hazardous location submersible pumps have two factory installed moisture detectors (seal failure probes). They are in a normally open series circuit in the seal chamber. Under normal operating conditions, the circuit remains open. If the lower seal leaks and moisture enters this chamber, the moisture would settle to the bottom of the chamber and will complete the circuit between the moisture detectors.

This circuit must be connected to a sensing unit and signaling device. This is supplied in a Hydromatic built control panel.

Pump:

The submersible pumps are supplied for one and three-phase and for 208, 230, 460 or 575 volts. Power cable is supplied with the green wire for ground. Be sure green wire is connected to an approved ground.

Heat Sensors:

All motors have heat sensor units embedded in the motor winding to detect excessive heat. The heat sensors are set to trip at 105°C, and 120°C for hazardous location, so it will not operate if dangerous heat occurs. The sensors automatically reset when motor cools to safe temperature.

The sensors are connected in series with the motor starter coil so that the starter is tripped if the heat sensor opens. The motor starter is equipped with overload heaters so all normal overloads are protected by the starter.

Once sensor resets, the starter is to be reset for FM for continued operation of

the pump. This circuitry is supplied in a Hydromatic control panel.

NOTE: Failure to install such circuitry would negate FM approvals and all warranties by Hydromatic.

IMPORTANT: If Hydromatic electrical starting equipment is not supplied, the heat sensor circuit must be connected in series with the starter coil or warranty is void.

Power Cords:

The power cord and heat sensor seal failure cord are potted into the connection box cap. The cords must not be spliced.

NOTE: Each cable has a green lead. This is the ground wire and must be grounded properly per NEC and/or local codes. Cords should be inspected for abnormal wear and replaced accordingly.

Sump Level Control:

The sump level is controlled by Hydromatic float switch controls. The float is held in position in the sump by a weight attached to the power cord above the float. The cord supports the float and is adjusted for height from the surface.

Typical duplex systems use three controls: one set at turn-off, one set at turn-on for one pump, and one set for turn-on for two pumps. Pumps alternate operation on each successive cycle.

Two pumps operate together only if sump level rises to the third or override control. The override control also brings on the second pump in case of failure of the first pump. Extra floats with appropriate controls can be supplied for alarm functions. Triplex systems use four controls: one set at turn-off, one set at turn-on for one pump, one set at turn-on for two pumps, and one set at turn-on for three pumps. Pumps alternate each successive cycle.

Three pumps operate together only if sump level rises to the fourth control (second override). This control also brings on the third pump in case of failure of either or both of the first two pumps.

Alarm Controls:

The alarm level is usually set above the override level so the alarm will signal only if the override level is exceeded. However, some engineers prefer to have the alarm level set below the override level as it is possible for one pump to fail and the other pump to operate on the override level with the sump level never reaching the alarm level. This is particularly true in cases of low inflow capacity.

Electrical Control Panel:

It is recommended that the Hydromatic control panel be used with all pumps as proper starter heaters and connections for heat sensor wires are furnished.

IMPORTANT: If Hydromatic electrical controls are not used and the motor fails because of improper components or if the heat sensors are not properly connected, the warranty is void.

Hydromatic electrical equipment is installed in a weatherproof NEMA 3R enclosure. The electrical equipment includes a main circuit breaker for each pump, a magnetic starter with overload protection for each pump, an H-O-A switch and run light for each pump, an electric alternator and a transformer to provide appropriate control for control circuit and alarms.

Overload Heaters:

If the Hydromatic electrical panel is not used, starters with three-leg overload protection must be supplied. On three-phase pumps the heaters must be sized in accordance with the nameplate amps on the motor housing. The amp draw on these submersible motors is slightly higher than a corresponding horsepower surface motor, so heaters must be sized by the nameplate rating.

Single-phase pumps with capacitor start have a run and a start winding, each drawing a different current. To adequately protect these windings with the appropriate heaters, consult the factory.

NOTE: Red lead is always the start winding of pump using single phase.

IMPORTANT: If other than Hydromatic starters are used, be sure the heat sensor wires are connected in series with the starter coil circuit.

Pump Installation

Installing Sump Level Control Float Controls:

In either simplex, duplex or triplex systems the lower or turn-off control is to be set to maintain a minimum level in the sump. This level shall be no more than 3-1/4" from the top of the motor housing down to the surface of the sewage.

The second or turn-on control is set above the lower turn-off control. The exact distance between the two floats must be a compromise between a frequent pumping cycle (10 starts per hour max.) to control septicity, solids and a slower cycle for energy economy. This distance should be determined by the engineer or consulting engineer depending on the conditions of the application.

Installing Pump in Sump:

Before installing pump in sump, lay it on its side and turn impeller manually. Impeller may be slightly stuck due to factory test water so it must be broken loose with a small bar or screwdriver in the edge of the vanes. The impeller should turn freely.

Clean all trash and sticks from sump and connect pump to piping.

A check valve must be installed on each pump. A gate or plug valve in each pump discharge line is also recommended. This valve should be installed on the discharge side of the check valve so that if necessary to service the check valve, the line pressure can be cut off. Single pump systems are sometimes installed without a check valve where it is desirable to self-drain the discharge line to prevent freezing. This can be done only with short discharge lines, otherwise water will return to the sump and cause short cycling of the pump.

NEMA 4 Junction Box: (Optional)

If the electrical control panel is to be set remotely from the pump sump a NEMA 4 junction box should be used to make power and control connections. The Hydromatic NEMA 4 junction box is provided with compression connectors for sealing all wires. No sealing compound is needed to make connections waterproof.

Wiring diagrams are provided with the panel for making connections. An extra set of diagrams is included so that one set can be used in the sump when making connections. The size wire to use from panel to sump depends on motor size and distance in feet. Be sure each wire is checked out so that a wrong connection will not be made.

Installing Switch Controls:

The controls are supported by a mounting bracket that is attached to sump wall, cover or to the NEMA 4 junction box.

Cord snubbers are used to hold the cord in place. Control level can be changed at any time by loosening the snubber and readjusting cord length.

In either simplex or duplex system the lower or turn-off control is set just above the top of the volute so that the volute will always be submerged during the pumping cycle. The second or turn-on control is set about 24 inches above the lower turn-off control.

More distance between turn-on and turn-off controls can be used but sewage may become septic and excessive solids may collect for the pump to handle. A frequent pumping cycle is recommended for best operation.

If an alarm system is used, this control is usually set about six inches above the override control.

Some engineers, as described previously, prefer to have the alarm control set below the override control.

Making Electrical Connections:

All electrical wiring must be in accordance with local code, and only competent electricians should make the installations. A set of prints is included for use in making the installation. All wires should be checked for grounds with an ohmmeter or Megger® after the connections are made. This is important, as one grounded wire can cause considerable trouble.

IMPORTANT: If the equipment is not properly wired and protected as recommended, the warranty is void.

Heat Sensors and Seal Failure Connections:

Be sure that heat sensor wires are connected in series with the starter coil. Connections are provided on the terminal strip; see wiring diagram.

Pump Operation

Starting System:

Turn H-O-A switch to Off position, then turn on main circuit breakers.

Open all discharge valves and allow water to rise in sump.

Turn H-O-A switch to Hand position on one pump and notice operation. If pump is noisy and vibrates, rotation is wrong. To change rotation on 3Ø motors, interchange any two line leads to motor. Do not interchange main incoming lines. If duplex system, check second pump in same manner.

Now set both H-O-A switches to Auto position and allow water to rise in sump until one pump starts. Allow pump to operate until level drops to turn-off point.

Allow sump level to rise to start other pump. Notice run lights on panel; pumps should alternate on each successive cycle of operation.

Turn both H-O-A switches to Off position and allow sump to fill to the override control level.

Turn both switches to Auto position and both pumps should start and operate together until level drops to turn-off point.

Repeat this operation cycle several times before leaving the job.

Check the voltage when pumps are operating and check the amp draw of each pump. Check amps on each wire

as sometimes a high leg will exist. One leg can be somewhat higher, 5 to 10%, without causing trouble. For excessive amp draw on one leg, the power company should be consulted.

Pump Maintenance

As the motors are oil filled no lubrication or other maintenance is required.

If the pump is used on a Hydrorail system, it should be lifted once every six months and checked for corrosion and wear.

Field Service on Motor:

All submersible motors out of warranty can be serviced in the field by any reliable motor service shop. Any pump (in warranty) must be returned to the factory for service or repaired at an authorized Hydromatic service center. Charges will not be allowed if (in warranty) pump is not taken to an authorized Hydromatic service center.

Field Service on Hydromatic Hazardous Location Pumps:

If a Hydromatic hazardous location pump is used in a hazardous location, or if the pump is still in warranty, the pump must be returned to the factory for service or repaired at an authorized Hydromatic service center. Charges will not be allowed if (in warranty) pump is not taken to an authorized Hydromatic service center. This will ensure the integrity of the hazardous location rating of the pump and comply with our warranty requirements.

Disconnecting Pump Cords:

If a Hydromatic hazardous location pump is to be removed from its location, the pump cords may be disconnected at the control panel (on sump mounted control panels) and cord assembly taken with pump. Do not reconnect power to a cord and cap assembly while removing from pump.

CAUTION: If cord openings from sump to control panel are open, gases from sump could enter panel and an explosive condition could exist.

Replacing Cords:

The power cord and heat sensor – seal failure cord is potted into the connection box cap, forming the cord and cap assembly.

If cords require replacement due to damage or cords being too short, cord and cap assembly must be replaced as a complete assembly available from factory.

Check pump for proper rotation before returning to normal service.

Replacing Lower Seal, Impeller or Volute:

The wet-end components may be repaired or replaced by an authorized Hydromatic service facility without compromising the hazardous location rating to the pump.

Replacing Stator:

If stator only is damaged, it may not be necessary to completely dismantle pump as stator and housing can be lifted from pump without disturbing seals or bearings.

Drain all oil from upper housing, remove from upper housing, remove drain plug in bottom of stator housing and remove plug in top of housing to allow air to enter.

After chamber is drained, remove hold-down bolts and lift off. Use care in lifting as the seal failure connecting wire must be disconnected before housing is completely removed.

Set assembly on bench and remove connection box. When box is lifted off, connection wires to motor will be exposed. These wires will probably be burned, but each wire is tagged with a metal marker giving the wire number. Cut the wires.

If the leads to the connection box are burned, a complete new connection box with new wire must be used. The wires are potted-in with sealing compound and a new unit must be obtained from the factory.

The stator is held in the housing with a bolted-in clamp ring.

After ring is removed, turn housing upright and bump on hardwood blocks. This should jar the stator loose and allow it to drop out.

Thoroughly clean housing before replacing new stator. Replace the stator and make all wire connections to the connection box before replacing housing on pump. This is important as leads must be tucked behind the windings by using hands up through rotor core.

IMPORTANT: Use only compression type insulated connectors on the wires. Do not tape leads as oil will deteriorate the tape and cause damage to stator and bearings.

Check top bearing. If clean and does not turn roughly, bearings can be reused and it is not necessary to completely dismantle pump to change bearings. If bearings are damaged with dirt or heat, they must be replaced. Remember to reinstall the upper bearing load spring.

Replace stator housing onto seal chamber and bolt in place. Be sure seal failure wire is connected before housing is assembled.

Be sure O-ring seal has been replaced. If O-ring is nicked or cut, replace with new rings. This applies to all O-rings used in assembly.

After all leads are reconnected in the connection box, make a high voltage ground test on each wire. The only wire that should show ground is the green power lead and the ground lead in the auxiliary control cable.

For safety, complete pump should be air checked under water for leaks. Lay pump on its side for this oil filling, with oil fill hole upright. Do not completely fill; leave oil about one inch below plug hole. Use only high grade transformer oil or regular Hydromatic submersible oil in this chamber. Replace plug; use Permatex® on threads. Install air valve in top plug opening of motor housing and charge housing with about 10 psi of air. Be sure air is dry. Do not use air line where water may be trapped in the line. Submerge complete unit under water and check for leaks.

Refill motor chamber with oil. Use high grade transformer oil or Hydromatic special submersible oil. Fill chamber until oil covers top of the windings. Leave air space in the top for expansion. Use Permatex on plug threads.

Replace Seals and Bearings:

Drain all oil from motor chamber and seal chamber as described.

Remove motor housing as described.

Remove bolts that hold seal chamber to pump housing. Use back-off screws to break loose. With hardwood block, tape end of impeller to loosen from shaft. When free, remove impeller from shaft.

Lift rotating assembly (rotor, shaft and impeller) from pump case and place horizontally on bench.

Impeller removal — Hold motor and remove bolt and washer from impeller end of shaft. Impeller is threaded to the shaft, so tap face of impeller with hardwood block to free threads. Holding rotor, turn impeller with hardwood block to free the threads. Holding rotor, turn impeller counterclockwise as thread is right-hand.

Remove lower seal spring and pry out seal with screwdriver.

To remove seal housing, take out socket head bolts and using bolts in back of holes, pry plates loose. This will force out lower seal if not already removed.

Remove snap ring that holds upper seal. Pull seal if it is free. If not free, it can be forced off when shaft is removed.

Remove four bolts that hold bearing housing in place. Set assembly in upright position and bump end of shaft

on hardwood block. This will push the bearing from the housing and will force upper seal from shaft.

Use bearing puller to remove bearings. Replace with new bearings. Press only on inner face of bearing when replacing. Pressing on outer face can damage the bearing.

IMPORTANT: Do not use any of the old seal parts. Replace with all new seals.

Thoroughly clean all castings before replacing seals.

Examine all O-rings for nicks before using.

Use Loctite® on socket head locking screw into the end of the shaft.

Before refilling chamber with oil, air test as described above. Refill both chambers with oil as described above.

Always check all leads with high voltage or with Megger for grounds before operating the pump.

Troubleshooting

Below is a list of common problems and the probable causes:

Pump will not start:

No power to the motor. Check for blown fuse or open circuit breaker.

Selector switch may be in the Off position.

Control circuit transformer fuse may be blown.

Overload heater on starter may be tripped. Push to reset.

Pump will not start and overload heaters trip:

Turn off power and check motor leads with Megger or ohmmeter for possible ground.

Check resistance of motor windings. All three phases should show the same reading.

If no grounds exist and the motor windings check OK, remove pump from sump and check for clogged or blocked impeller.

Pump operates with selector switch in Hand position but will not operate in Auto position:

This indicates trouble in the float level control or the alternator relay.

To check for a defective float control, put selector switch in Auto position and turn off main power. Put a jump wire on terminal strip. Turn on power and if pump starts, trouble is in the float control. Replace control.

Pump runs but will not shut off:

Pump may be air locked. Turn pump off and let set for several minutes, then restart.

Lower float control may be hung-up in the closed position. Check in sump to be sure control is free.

Selector switch may be in the Hand position.

Pump does not deliver proper capacity:

Discharge gate valve may be partially closed or partially clogged.

Check valve may be partially clogged. Raise level up and down to clear.

Pump may be running in wrong direction. Low speed pumps can operate in reverse direction without much noise or vibration.

Discharge head may be too high. Check total head with gauge when pump is operating. Total head is discharge gauge pressure converted to feet plus vertical height from water level in sump to center line of pressure gauge in discharge line. Gauge should be installed on pump side of all valves. Multiply gauge pressure in pounds by 2.31 to get head in feet.

If pump has been in service for some time and capacity falls off, remove pump and check for wear or clogged impeller.

Motor stops and then restarts after short period but overload heaters in starter do not trip:

This indicates heat sensors in the motor are tripping due to excessive heat. Impeller may be partially clogged giving a sustained overload but not high enough to trip overload heater switch.

Motor may be operating out of liquid due to a failed level control. All Hydromatic submersible motors can operate for extended periods out of water without burning up the winding, but the heat sensors give motor prolonged life by controlling winding temperature.

Pump may be operating on a short cycle due to sump being too small or from water returning to sump due to a leaking check valve.

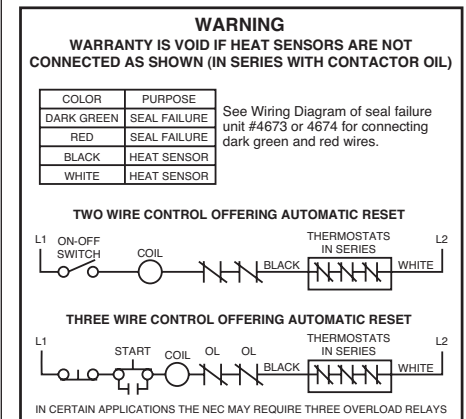
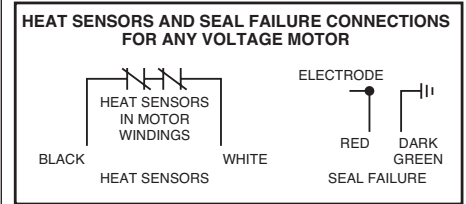
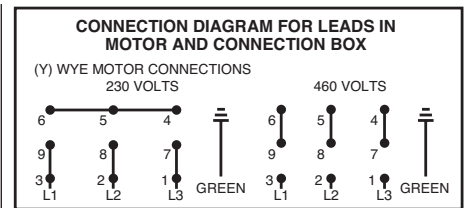

Wiring Diagrams

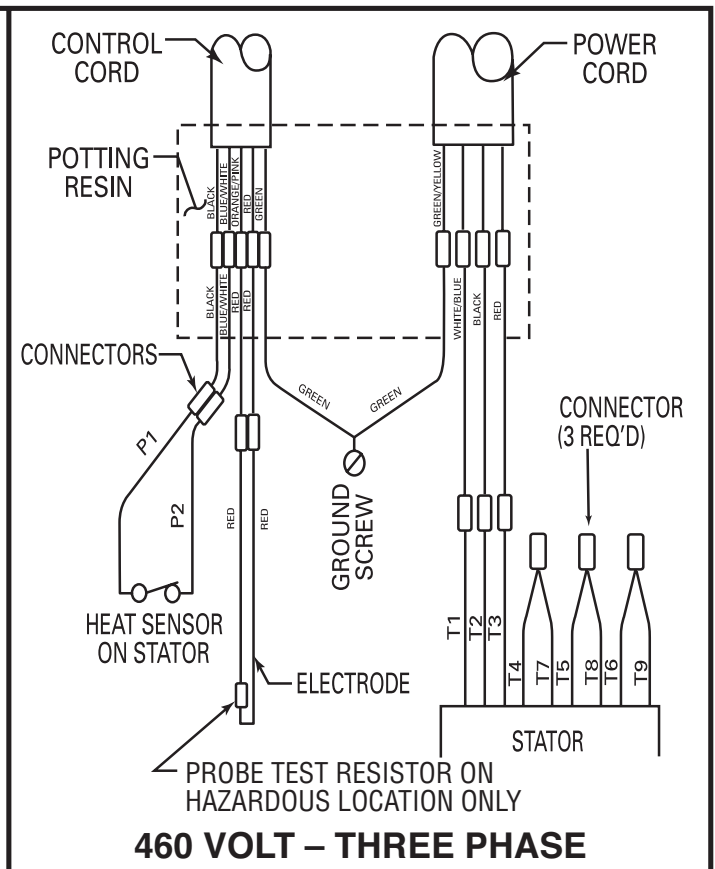
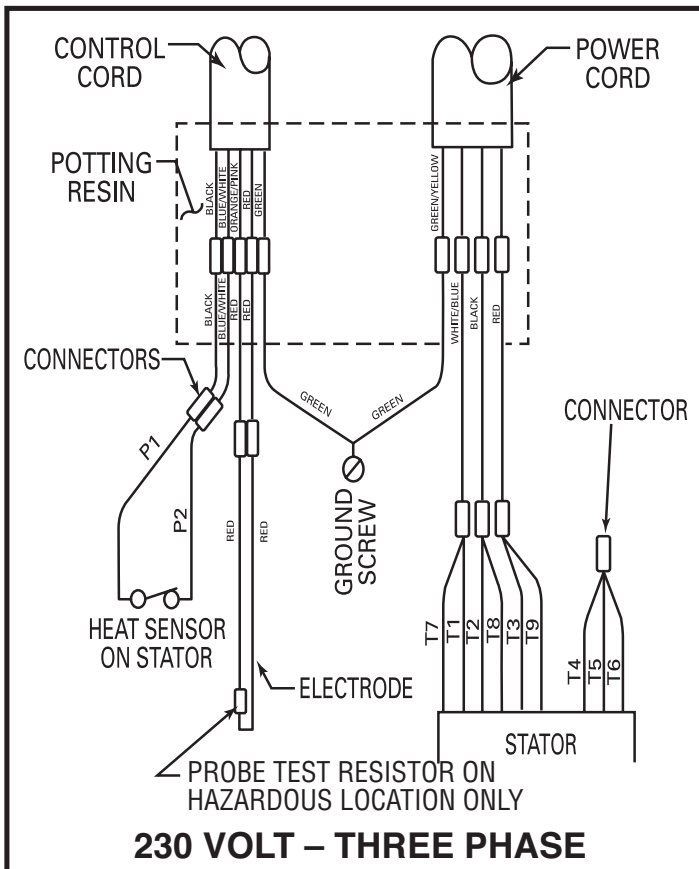
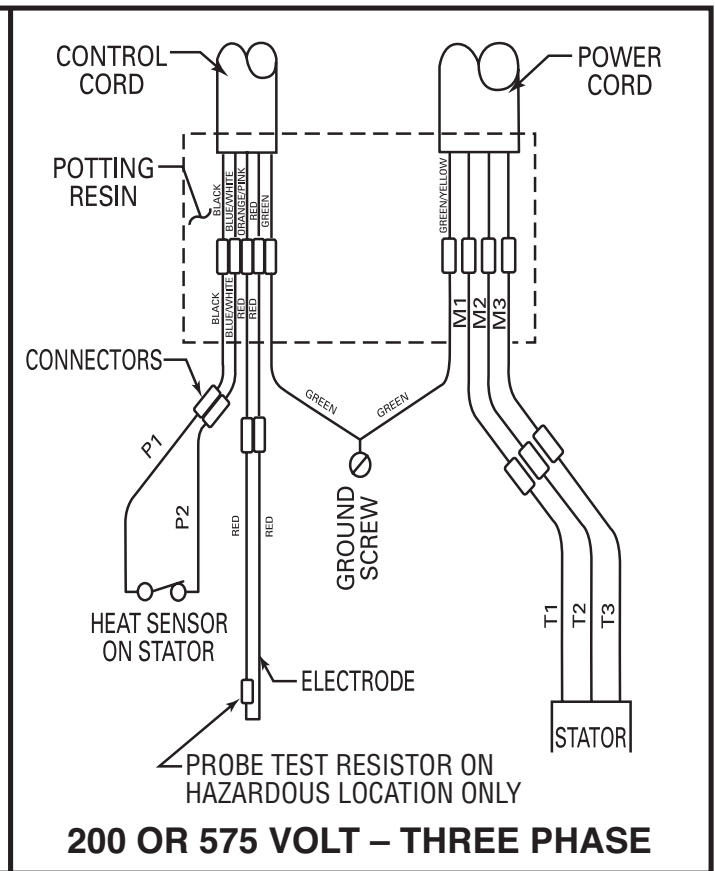
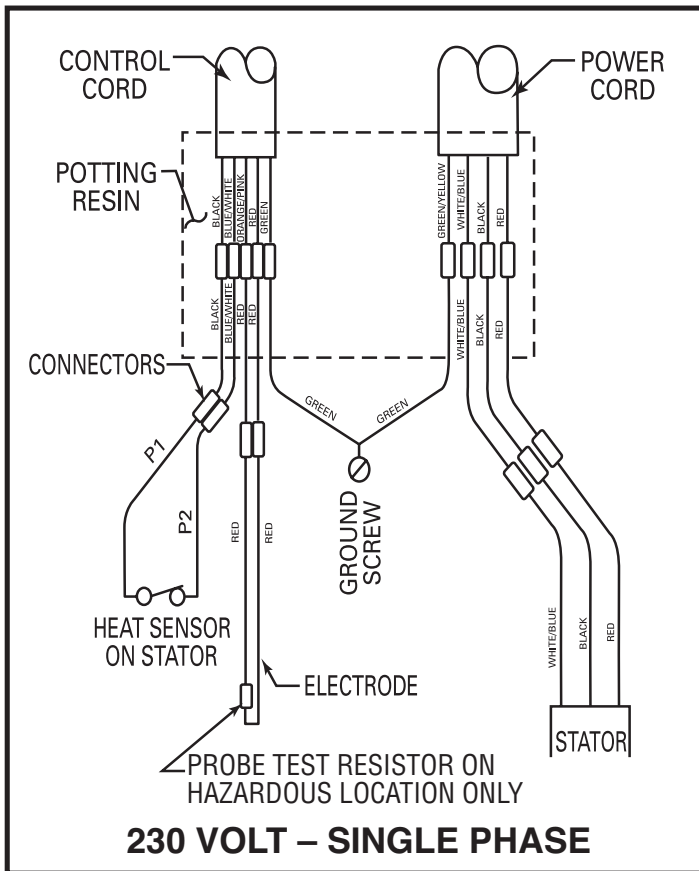

Wiring Diagrams

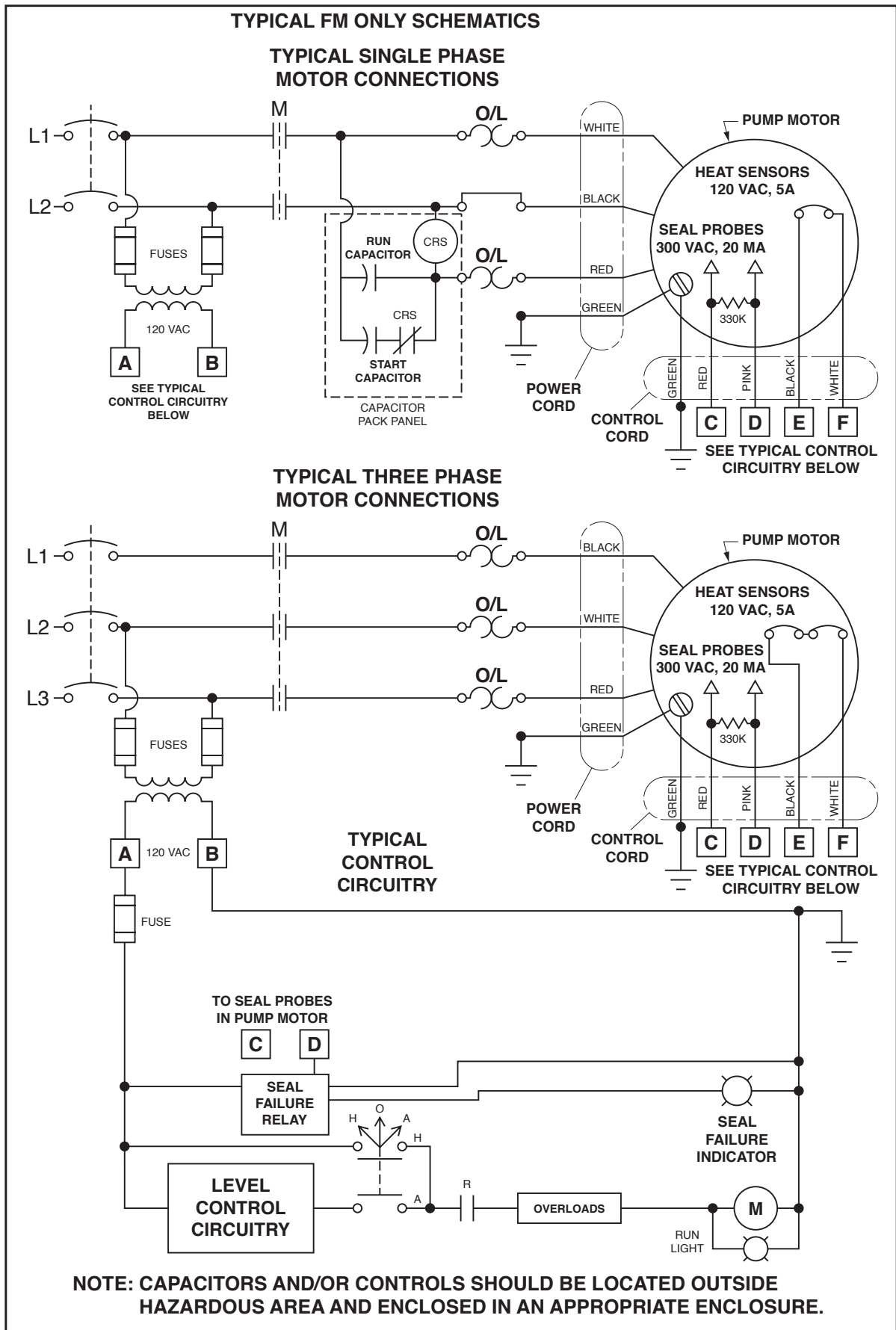

S3HRC Parts List

Item	Eng. No.	Part Description	Qty.
1	024940001	Wire Connector – 200/230V, 1φ, 5 hp	3
	008530001	Wire Connector – 230V, 3φ, All hp	4
	005570001	Wire Connector – 460V, 3φ, All hp	6
2	152740355	35' Cord Assembly 14-4	1
	152740345	35' Cord Assembly 12-4	1
	152740305	35' Cord Assembly 10-4	1
	152740315	35' Cord Assembly 8-4 S00W	1
	152740325	35' Cord Assembly 8-4 W	1
3	002820011	Wire Connector – 3 hp, 1φ, 200/575/3/60	6
	002820011	Wire Connector – 5 hp, 1φ, 230/460/3/60	12
4	000730011	Wire Connector	3
5	054300025	Wire Connection Box Assy. – 200/230/60, 3 hp; 200/575/3/60, 3 & 5 hp	1
	054300055	Wire Connection Box Assy. – 230/460/3/60, All hp; 200/230/1/60, 5 hp	1
6	000650211	Upper Bearing	1
7	008340101	O-ring	1
8	000640031	Load Spring	1
9	007360011	Stator Spacer Ring – 3 hp, 200/230/3/60	1
	007360031	Stator Spacer Ring – 3 hp, 200/230/1/60	1
	007360011	Stator Spacer Ring – 5 hp, 200/230/460/575/3/60	1
10	002940012	Motor Cover – 3 hp, 3φ Only	1
	002940022	Motor Cover – All Others	1
11	060000141	Wire w/Terminal	1
12	002990021	Stator Ring	1
13	005170081	Bolt – 3 hp, 5 hp, 1φ; 5 hp, 3φ	4
	005170071	Bolt – 3 hp, 3φ	4
14	005680071	Bolt	4
15	071200002	Seal Housing	1
16	071210002	Bearing Housing	1
17	19109A018	Nut	4
18	010270061	Stud	4
19	071310001	Gasket	1
20	105-014034-263	Bolt	3
	003000001	Seal (Ceramic) Std.	2
21	006960001	Seal (Carbide) Opt.	1
	005190011	Washer	1
23	005560031	Bolt	1
24	147690012	Impeller – 5" Dia.	1
	147690022	Impeller – 4-3/4" Dia. (4.75)	1
	147690222	Impeller – 3-15/16" Dia. (3.95)	1
	147690252	Impeller – 3-5/16" Dia. (3.30)	1
25	071180002	Volute Case	1
26	001500291	O-ring	1
27	009750021	Snap Ring	1
28	146892031	Stator – 3 hp, 200/1/60, 3450 rpm	1
	22574C210	Stator – 3 hp, 230/1/60, 3450 rpm	1
	22574C211	Stator – 3 hp, 200/3/60, 3450 rpm	1
	22574C212	Stator – 3 hp, 230/460/3/60, 3450 rpm	1
	22574C214	Stator – 3 hp, 575/3/60, 3450 rpm	1
	22574C218	Stator – 5 hp, 200/1/60, 3450 rpm	1
	146910031	Stator – 5 hp, 230/1/60, 3450 rpm	1
	22574C201	Stator – 5 hp, 200/3/60, 3450 rpm	1
	146920031	Stator – 5 hp, 230/460/3/60, 3450 rpm	1
	22574C204	Stator – 5 hp, 575/3/60, 3450 rpm	1
	22574C216	Stator – 7.5 hp, 230/460/3/60, 3450 rpm	1
	22574C217	Stator – 7.5 hp, 575/3/60, 3450 rpm	1
	22574C215	Stator – 7.5 hp, 200/3/60, 3450 rpm	1

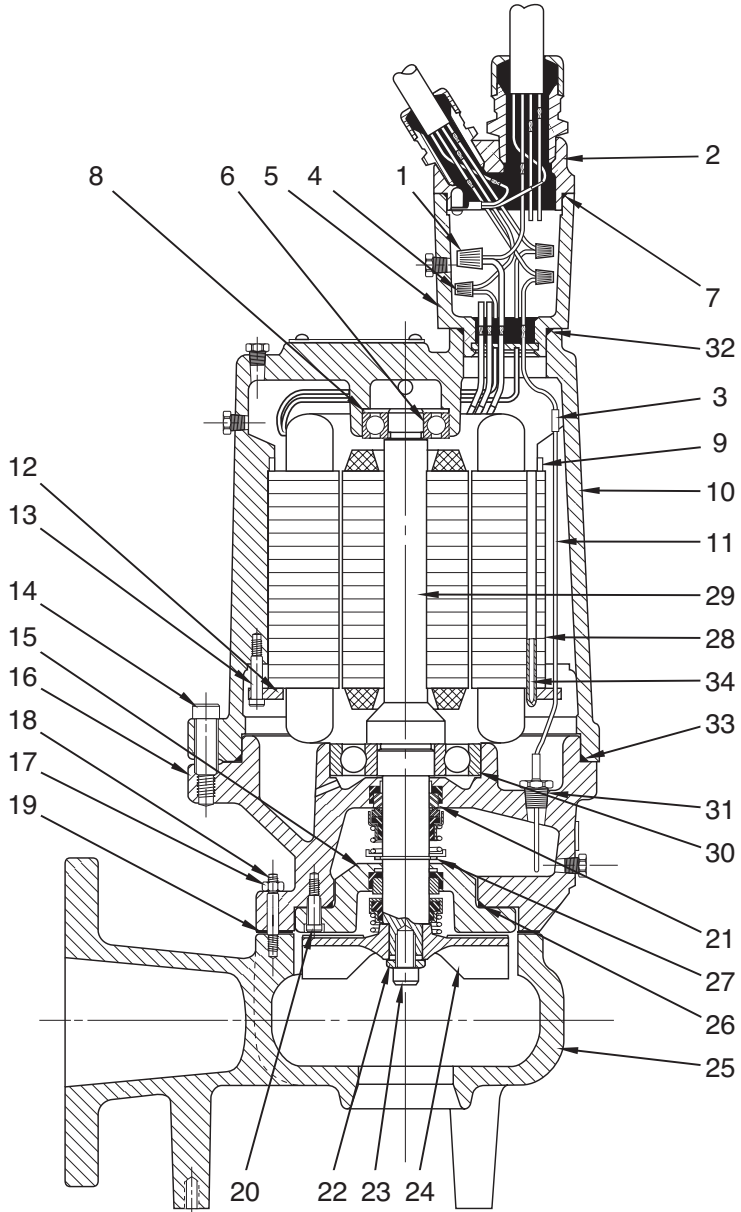

Item	Eng. No.	Part Description	Qty.
29	080530115	Rotor & Shaft Assy. – 3 hp, 200/230/1/60	1
	084340115	Rotor & Shaft Assy. – 3 hp, 200/230/460/575/3/60	1
	007640135	Rotor & Shaft Assy. – 5 hp, 200/230/1/60	1
	007650135	Rotor & Shaft Assy. – 5 hp, 200/230/460/575/3/60	1
	007640135	Rotor & Shaft Assy. – 7.5 hp, 200/230/460/575/3/60	1
30	000650181	Lower Bearing	1
31	084720015	Seal Failure Assy.	1
32	008340081	O-ring	1
33	001500571	O-ring	1
34	054540011	Spring Pin	1
	517000227	Seal Kit	
	517003227	Carbide Seal Kit	

S3HVX Parts List

For use with product built with Marathon® motor.

Item	Eng. No.	Part Description	Qty.
1	152730355	35' Cord Assembly 14-4	1
	152730345	35' Cord Assembly 12-4	1
	152730305	35' Cord Assembly 10-4	1
	152730335	35' Cord Assembly 8-4	1
2	008530001	Connector 230/460/3/60	4
	005570001	Connector 200/230/1/60, 200/575/3/60	3
3	008340081	O-ring	1
4	108980001	Connector	4
5	108990001	Connector 230/460/3/60	9
	108990001	Connector 200/230/1/60, 200/575/3/60	3
6	054540011	Roll Pin	1
7	002990021	Stator Holding Ring	1
8	08565A027	Lower Bearing	1
9	001500201	O-ring	1
10	109000015	Seal Sensor Assy.	1
11	109010001	Seal Failure, Probe	2
12	001190161	Pipe Plug	2
13	109020001	Safety Wire	1
14	001500111	O-ring	1
15	002390071	Capscrew	4
16	008340231	O-ring	1
17	107520002	Seal Plate	1
18	147690252	Impeller 3.30 Dia.	1
	147690222	Impeller 3.95 Dia.	1
	147690022	Impeller 4.75 Dia.	1
19	002380021	Capscrew, Steel (non UL)	3
	002380091	Capscrew, Brz. (UL)	3
20	005190011	Washer	1
21	005560031	Capscrew	1
22	009950081	Lock Washer	4
23	003000001	Lower Seal (Ceramic) Std.	1
	006960001	Lower Seal (Carbide) Opt.	1
24	107690002	Volute	1
25	005170041	Capscrew	3
26	009750121	Retainer Ring	1
27	107430012	Bearing Housing	1
28	049160001	Upper Seal	1
29	005680071	Capscrew	4
30	002380061	Capscrew S.ST.	2
31	005170071	Capscrew	4
32	22574C210	Stator 3 hp 230/1/60 3450 rpm	1
	146892031	Stator 3 hp 200/1/60 3450 rpm	1
	22574C212	Stator 3 hp 230/460/3/60 3450 rpm	1
	22574C211	Stator 3 hp 200/3/60 3450 rpm	1
	22574C214	Stator 3 hp 575/3/60 3450 rpm	1
	22574C200	Stator 5 hp 230/1/60 3450 rpm	1
	146920031	Stator 5 hp 230/460/3/60 3450 rpm	1
	22574C201	Stator 5 hp 200/3/60 3450 rpm	1
	22574C204	Stator 5 hp 575/3/60 3450 rpm	1
	22574C216	Stator 7.5 hp 230/460/3/60 3450 rpm	1
	22574C217	Stator 7.5 hp 575/3/60 3450 rpm	1
	22574C215	Stator 7.5 hp 200/3/60 3450 rpm	1

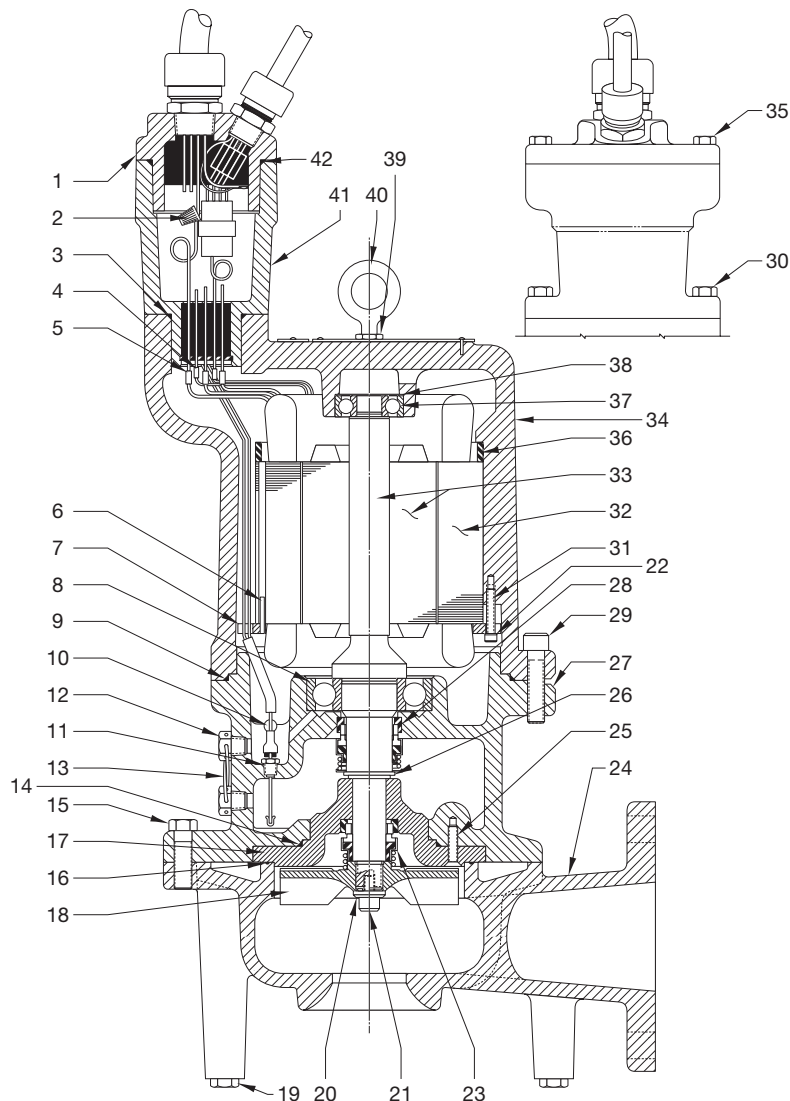

Item	Eng. No.	Part Description	Qty.
33	080530145	Rotor & Shaft 3 hp 1 ph.	1
	084340145	Rotor & Shaft 3 hp 3 ph.	1
	007640125	Rotor & Shaft 5 hp 230/1/60, 7.5 hp 200/230/460/575/3/60	1
34	007650165	Rotor & Shaft 5 hp 3 ph.	1
	107650022	Motor Housing 5 hp 3 ph.	1
35	107650032	Motor Housing (All Others)	1
	001010071	Capscrew S.ST.	2
36	007360021	Spacer 3 hp 3 ph.	1
	007360011	Spacer 5 hp 3 ph.	1
37	000650211	Upper Bearing	1
38	000640031	Load Spring	1
39	010320021	Nut	2
40	005890021	Eyebolt	1
41	108950005	Conn. Box 230/460/3/60	1
	108950015	Conn. Box 200/230/1/60, 200/575/3/60	1
42	008340131	O-ring	1
	517000567	Seal Kit	
	517003567	Carbide Seal Kit	

S4NRC Parts List

Item	Eng. No.	Part Description	Qty.
1	008530001	Wire Connector (230/3/60)	4
	005570001	Wire Connector (460/3/60)	6
	005570001	Wire Connector (200/230/1/60 & 200/575/3/60)	3
2	009950081	Lock Washer	4
3	152740355	35' Cord Assembly 14-4	1
	152740345	35' Cord Assembly 12-4	1
	152740305	35' Cord Assembly 10-4	1
	152740315	35' Cord Assembly 8-4 500W	1
	152740325	35' Cord Assembly 8-4 W	1
4	000730011	Wire Connector (Dual Cord)	3
5	054300025	Connection Box Assy. 200/3/60 & 200/1/60	1
	054300055	Connection Box Assy. 230/460/3/60	1
6	000650211	Upper Bearing	1
7	007360011	Spacer Ring 200/230/1/60 1 hp	1
	007360031	Spacer Ring 200/230/460/575/3/60 1 hp	1
8	000640031	Load Spring	1
9	002820011	Wire Connector 1Φ 575/3/60 & 200/3/60	6
	002820011	Wire Connector 230/460/3/60	12
10	008340081	O-ring	1
11	008340101	O-ring	1
12	002990021	Stator Retainer Ring	1
13	005170071	Soc. Hd. Cap Screw 1 hp 3Φ	4
	005170081	Soc. Hd. Cap Screw All Other hp & Φ	4
14	005680071	Soc. Hd. Cap Screw	4
15	071200002	Seal Housing	1
16	071450002	Bearing Housing	1
17	060000141	Seal Failure Wire Assy.	1
18	010240071	Stud	4
19	008520041	Nut	4
20	008340241	O-ring	1
21	005170041	Soc. Hd. Cap Screw	3
22	003000001	Seal (Ceramic) Std.	1
	006960001	Seal (Carbide) Opt.	1
23	005190011	Lock Washer & Pin Assy.	1
24	005560031	Soc. Hd. Cap Screw	1
25	071440002	Impeller 8" Dia.	1
	071440062	Impeller 7.85" Dia.	1
	071440082	Impeller 7.30" Dia.	1
	071440092	Impeller 7.20" Dia.	1
	071440112	Impeller 6.40" Dia.	1
	071440132	Impeller 5.90" Dia.	1
	071440142	Impeller 5.50" Dia.	1
26	071430012	Volute Case	1
27	001500291	O-ring	1
28	009750121	Snap Ring	1
29	049160001	Seal	1
30	002940022	Motor Housing	1
31	000650181	Lower Bearing	1
32	084720015	Seal Failure Assy.	1
33	058990021	Shrinkable Tubing	1
34	001500571	O-ring	1
35	054540011	Spring Pin	1
36	147152031	Stator 1 hp 200/1/60 1150 rpm	1
	24407C223	Stator 1 hp 230/1/60 1150 rpm	1
	24407C224	Stator 1 hp 200/3/60 1150 rpm	1
	24407C225	Stator 1 hp 230/460/3/60 1150 rpm	1
	24407C226	Stator 1 hp 575/3/60 1150 rpm	1
	147172031	Stator 2 hp 200/1/60 1150 rpm	1
	24407C231	Stator 2 hp 230/1/60 1150 rpm	1
	24407C232	Stator 2 hp 200/3/60 1150 rpm	1
	24407C233	Stator 2 hp 230/460/3/60 1150 rpm	1

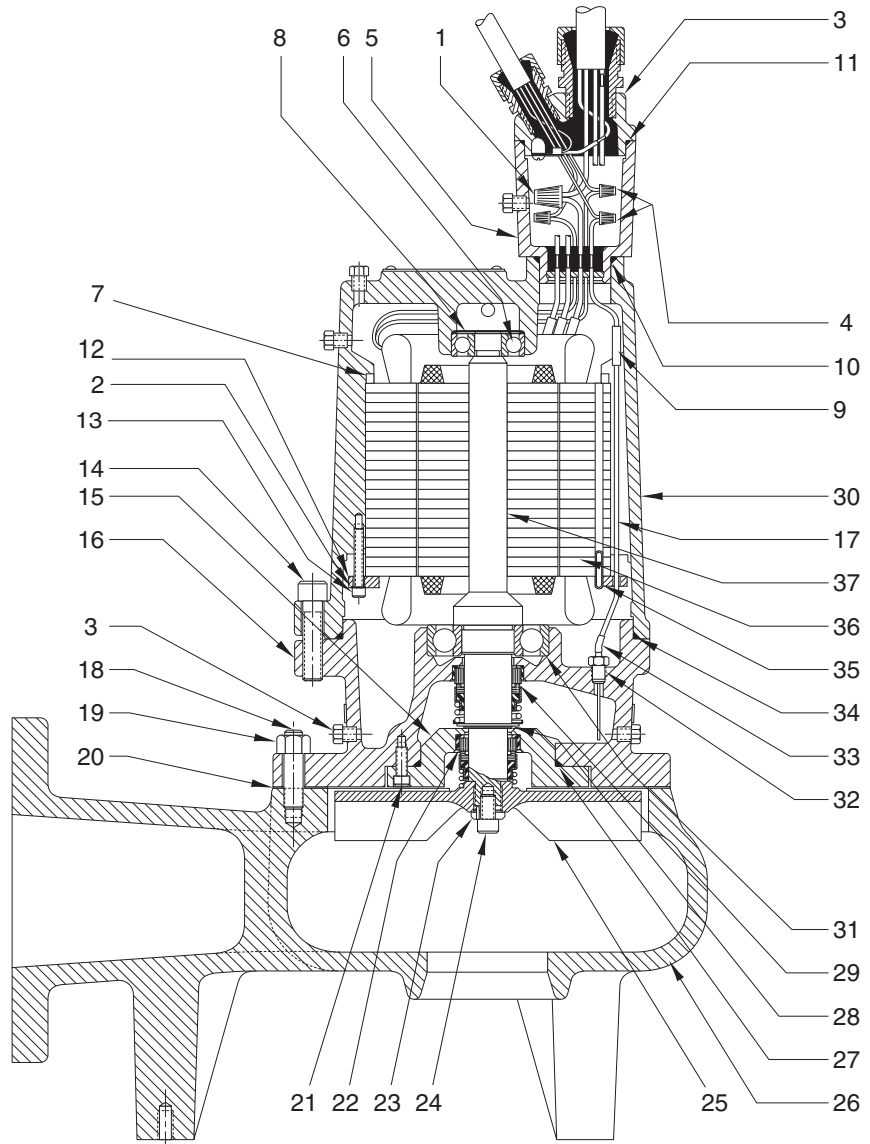

Item	Eng. No.	Part Description	Qty.
36 Cont.	24407C234	Stator 2 hp 575/3/60 1150 rpm	1
	24407C200	Stator 3 hp 230/1/60 1750 rpm	1
	24407C201	Stator 3 hp 200/3/60 1750 rpm	1
	24407C202	Stator 3 hp 230/460/3/60 1750 rpm	1
	24407C203	Stator 3 hp 575/3/60 1750 rpm	1
	24407C204	Stator 5 hp 230/1/60 1750 rpm	1
	24407C205	Stator 5 hp 200/3/60 1750 rpm	1
	24407C206	Stator 5 hp 230/460/3/60 rpm	1
	24407C207	Stator 5 hp 575/3/60 1750 rpm	1
	24407C208	Stator 7.5 hp 200/3/60 1750 rpm	1
	24407C209	Stator 7.5 hp 230/460/3/60 1750 rpm	1
24407C210	Stator 7.5 hp 575/3/60 1750 rpm	1	

Item	Eng. No.	Part Description	Qty.
37	077740125	Rotor & Shaft Assy. 1 hp 200/230/1/60	1
	077730125	Rotor & Shaft Assy. 1 hp 200/230/460/575/3/60	1
	013290135	Rotor & Shaft Assy. 2 hp 200/230/1/60	1
	007400135	Rotor & Shaft Assy. 2 hp 200/230/460/575/3/60	1
	013290135	Rotor & Shaft Assy. 3-7.5 hp 200/230/1/60 200/230/460/575/3/60	1
	517000177	Seal Kit	
	517003177	Carbide Seal Kit	

S4NVX Parts List

For use with product built with Marathon® motor.

Item	Eng. No.	Part Description	Qty.
1	152730355	35' Cord Assembly 14-4	1
	152730345	35' Cord Assembly 12-4	1
	152730305	35' Cord Assembly 10-4	1
	152730315	35' Cord Assembly 8-4 S00W	1
	152730335	35' Cord Assembly 8-4 W	1
	2	005570001	Connector 200/230/1/60, 200/575/3/60
024940001		Connector 200/230/460/575/3/60 (7-1/2 hp)	3
3	008340081	O-ring	1
4	108980001	Connector	4
5	108990001	Connector 230/460/3/60	9
	108990001	Connector 200/230/1/60, 200/575/3/60	3
6	054540011	Roll Pin	1
7	002990021	Stator Holding Ring	1
8	000650201	Lower Bearing	1
9	001500201	O-ring	1
10	109000015	Seal Sensor Assy.	1
11	109010001	Seal Failure Probe	2
12	001190161	Pipe Plug	2
13	009950081	Lock Washer	4
14	05876A106	O-ring	1
15	19103A043	Capscrew	4
16	008340241	O-ring	1
17	107520002	Seal Plate	1
18	071440052	Impeller 7.95"	1
	071440062	Impeller 7.85"	1
	071440082	Impeller 7.30"	1
	071440092	Impeller 7.20"	1
	071440112	Impeller 6.40"	1
	071440132	Impeller 5.90"	1
	071440142	Impeller 5.50"	1
19	19101A017	Capscrew S.ST.	3
20	005190011	Washer	1
21	005560031	Capscrew S.ST.	1
22	19101A017	Capscrew	2
23	003000001	Lower Seal Ceramic (Std.)	1
	006960001	Lower Seal Carbide (Opt.)	1
24	071430012	Volute	1
25	105-014034-263	Capscrew S.ST.	3
26	009750121	Retaining Ring	1
27	107430012	Bearing Housing	1
28	049160001	Upper Seal	1
29	005680071	Capscrew	4
30	19100A029	Capscrew	2
31	005170081	Capscrew	4
	24407C223	Stator 1 hp 230/1/60 1150 rpm	1
32	147152031	Stator 1 hp 200/1/60 1150 rpm	1
	24407C225	Stator 1 hp 230/460/3/60 1150 rpm	1
33	24407C224	Stator 1 hp 200/3/60 1150 rpm	1
	24407C226	Stator 1 hp 575/3/60 1150 rpm	1
34	24407C231	Stator 2 hp 230/1/60 1150 rpm	1
	147172031	Stator 2 hp 200/1/60 1150 rpm	1
35	24407C233	Stator 2 hp 230/460/3/60 1150 rpm	1
	24407C232	Stator 2 hp 200/3/60 1150 rpm	1
36	24407C234	Stator 2 hp 575/3/60 1150 rpm	1
	24407C200	Stator 3 hp 230/1/60 1750 rpm	1
37	24407C202	Stator 3 hp 230/460/3/60 1750 rpm	1
	24407C201	Stator 3 hp 200/3/60 1750 rpm	1
38	24407C203	Stator 3 hp 575/3/60 1750 rpm	1
	24407C206	Stator 5 hp 230/460/3/60 1750 rpm	1

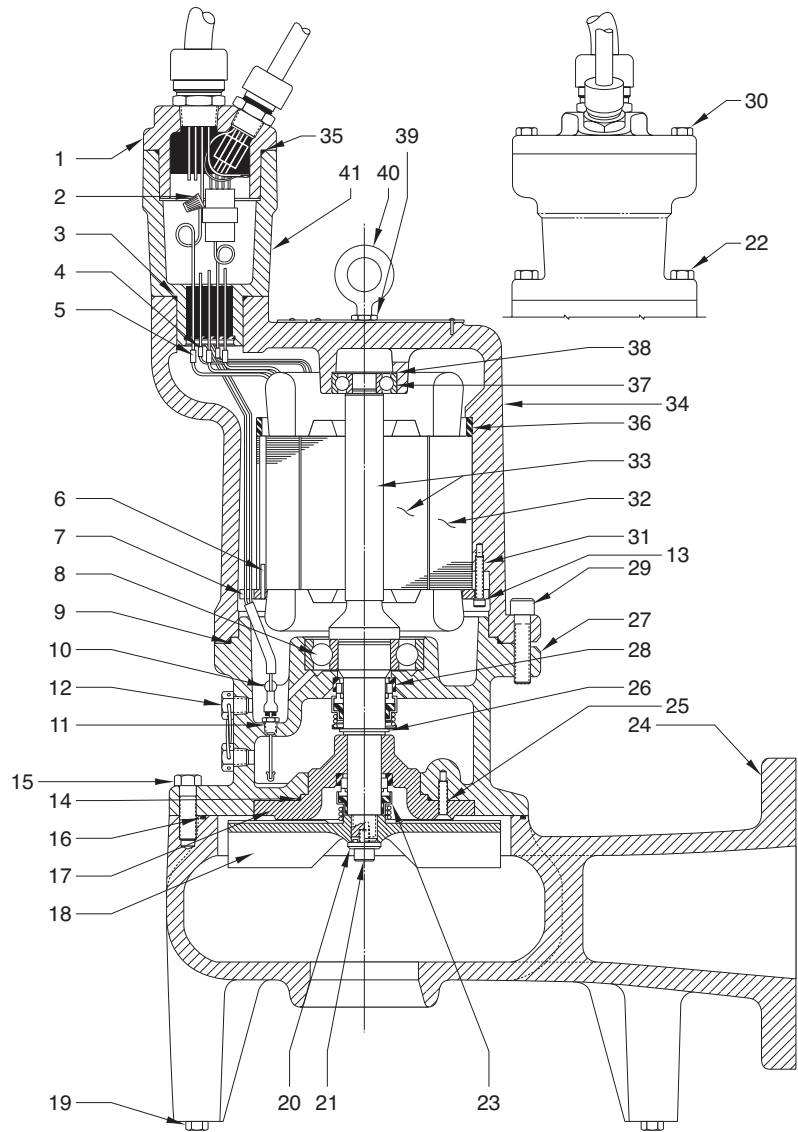

Item	Eng. No.	Part Description	Qty.
32 Cont.	24407C205	Stator 5 hp 200/3/60 1750 rpm	1
	24407C207	Stator 5 hp 575/3/60 1750 rpm	1
	24407C209	Stator 7-1/2 hp 230/460/3/60 1750 rpm	1
	24407C208	Stator 7-1/2 hp 200/3/60 1750 rpm	1
	24407C210	Stator 7-1/2 hp 575/3/60 1750 rpm	1
33	077740155	Rotor w/Shaft 1 hp 1 phase 1150 rpm	1
	077730155	Rotor w/Shaft 1 hp 3 phase 1150 rpm	1
	013290185	Rotor w/Shaft 2 hp 1 phase 1150 rpm	1
	007400165	Rotor w/Shaft 2 hp 3 phase 1150 rpm	1
	013290185	Rotor w/Shaft 3 hp 1 phase 1750 rpm	1
	013290185	Rotor w/Shaft 3-5 hp 3 phase 1750 rpm	1
	013290185	Rotor w/Shaft 7-1/2 hp 3 phase 1750 rpm	1
34	107650032	Motor Housing 1 hp 3 phase 1150 rpm	1
	107650022	Motor Housing (all others)	1

Item	Eng. No.	Part Description	Qty.
35	008340131	O-ring	1
36	007360011	Spacer 1-2 hp 3 phase 1150 rpm	1
	007360021	Spacer 1 hp 1 phase 1150 rpm	1
37	000650211	Upper Bearing	1
38	000640031	Load Spring	1
39	010320021	Nut	1
40	005890021	Eyebolt	1
41	108950005	Conn. Box 230/460/3/60	1
	108950015	Conn. Box 200/230/1/60, 200/575/3/60	1
	517000567	Seal Kit	
	517003567	Carbide Seal Kit	

STANDARD LIMITED WARRANTY

Pentair Hydromatic® warrants its products against defects in material and workmanship for a period of 12 months from the date of shipment from Pentair Hydromatic or 18 months from the manufacturing date, whichever occurs first – provided that such products are used in compliance with the requirements of the Pentair Hydromatic catalog and technical manuals for use in pumping raw sewage, municipal wastewater or similar, abrasive-free, noncorrosive liquids.

During the warranty period and subject to the conditions set forth, Pentair Hydromatic, at its discretion, will repair or replace to the original user, the parts that prove defective in materials and workmanship. Pentair Hydromatic reserves the right to change or improve its products or any portions thereof without being obligated to provide such a change or improvement for prior sold and/or shipped units.

Start-up reports and electrical schematics may be required to support warranty claims. Submit at the time of start up through the Pentair Hydromatic website: <http://forms.pentairliterature.com/startupform/startupform.asp?type=h>. Warranty is effective only if Pentair Hydromatic authorized control panels are used. All seal fail and heat sensing devices must be hooked up, functional and monitored or this warranty will be void. Pentair Hydromatic will cover only the lower seal and labor thereof for all dual seal pumps. Under no circumstance will Pentair Hydromatic be responsible for the cost of field labor, travel expenses, rented equipment, removal/reinstallation costs or freight expenses to and from the factory or an authorized Pentair Hydromatic service facility.

This limited warranty will not apply: (a) to defects or malfunctions resulting from failure to properly install, operate or maintain the unit in accordance with the printed instructions provided; (b) to failures resulting from abuse, accident or negligence; (c) to normal maintenance services and parts used in connection with such service; (d) to units that are not installed in accordance with applicable local codes, ordinances and good trade practices; (e) if the unit is moved from its original installation location; (f) if unit is used for purposes other than for what it is designed and manufactured; (g) to any unit that has been repaired or altered by anyone other than Pentair Hydromatic or an authorized Pentair Hydromatic service provider; (h) to any unit that has been repaired using non factory specified/OEM parts.

Warranty Exclusions: PENTAIR HYDROMATIC MAKES NO EXPRESS OR IMPLIED WARRANTIES THAT EXTEND BEYOND THE DESCRIPTION ON THE FACE HEREOF. PENTAIR HYDROMATIC SPECIFICALLY DISCLAIMS THE IMPLIED WARRANTIES OF MERCHANTABILITY AND FITNESS FOR ANY PARTICULAR PURPOSE.

Liability Limitation: IN NO EVENT SHALL PENTAIR HYDROMATIC BE LIABLE OR RESPONSIBLE FOR CONSEQUENTIAL, INCIDENTAL OR SPECIAL DAMAGES RESULTING FROM OR RELATED IN ANY MANNER TO ANY PENTAIR HYDROMATIC PRODUCT OR PARTS THEREOF. PERSONAL INJURY AND/OR PROPERTY DAMAGE MAY RESULT FROM IMPROPER INSTALLATION. PENTAIR HYDROMATIC DISCLAIMS ALL LIABILITY, INCLUDING LIABILITY UNDER THIS WARRANTY, FOR IMPROPER INSTALLATION. PENTAIR HYDROMATIC RECOMMENDS INSTALLATION BY PROFESSIONALS.

Some states do not permit some or all of the above warranty limitations or the exclusion or limitation of incidental or consequential damages and therefore such limitations may not apply to you. No warranties or representations at any time made by any representatives of Pentair Hydromatic shall vary or expand the provision hereof.



HYDROMATIC®

740 EAST 9TH STREET
ASHLAND, OHIO, USA 44805
419-289-1144

490 PINEBUSH ROAD, UNIT #4
CAMBRIDGE, ONTARIO, CANADA N1T 0A5
800-363-PUMP

WWW.HYDROMATIC.COM

Warranty Rev. 12/13