

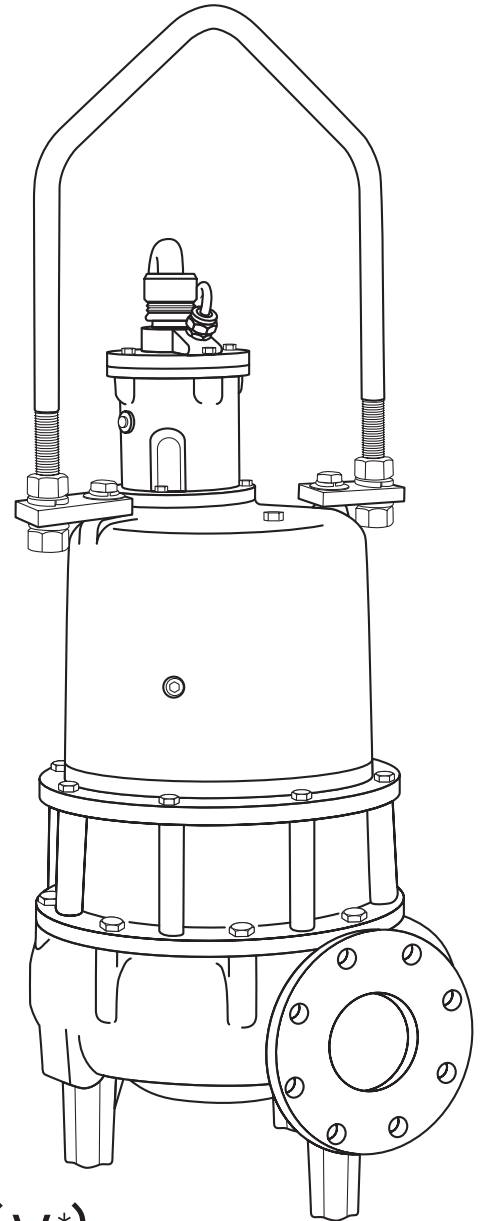

HYDROMATIC®



MODELS

S4L(X*), S4LRC/S4LVX*,
S4B(X*), S4K(X*), H4Q(X*),
S6L(X*), S6A(X*) and S8F(X*)

*Used in Hazardous Locations Class I, Division 1

SUBMERSIBLE SOLIDS HANDLING PUMPS

INSTALLATION AND SERVICE MANUAL

For use with product built with USEM motor.

NOTE! To the installer: Please make sure you provide this manual to the owner of the equipment or to the responsible party who maintains the system.

(*Hazardous Location
Motor End)



General Information

This manual contains important information for the safe use of this product. Read this manual completely before using this product and refer to it often for continued safe product use. **DO NOT THROW AWAY OR LOSE THIS MANUAL.**

When unpacking unit, check for concealed damage. Claims for damage must be made at the receiving end through the delivery carrier. Damage cannot be processed from the factory.

WARNING: Before handling these pumps and controls, always disconnect the power first. Do not smoke or use sparkable electrical devices or flames in a septic (gaseous) or possible septic sump.

CALIFORNIA PROPOSITION 65 WARNING:

⚠ WARNING This product and related accessories contain chemicals known to the State of California to cause cancer, birth defects or other reproductive harm.

Pumps Not Operating or in Storage:

Pumps with carbon ceramic seals must have impellers manually rotated (6 revolutions) after setting non-operational for 3 months or longer and prior to electrical start-up.

Pumps with tungsten carbide seals must have impellers manually rotated (6 revolutions) after setting non-operational for 3 weeks or longer and prior to electrical start-up.

Seal Failure:

An electrode probe is installed in the seal chamber so if any water enters the chamber through the first seal, the electrode will be energized and a signal will be transmitted to

the sensing unit at ground surface causing a red light to flash. The electrode probe is installed in all units, but the sensing unit is supplied at extra cost and must be ordered.

In operation the seal failure unit indicates only that there is some water in the seal chamber. The pump will continue to operate without damage, but the seal should be checked immediately after failure is indicated.

CAUTION: Failure to correct leaking seal could result in water entering motor chamber causing shorting out of motor.

The sensing unit is recommended on all installations as good insurance against motor failure.

Seal Failure Probes:

All our hazardous location submersible pumps have two factory installed moisture detectors (seal failure probes). They are in a normally open series circuit, in the seal chamber. Under normal operating conditions, the circuit remains open. If the lower seal leaks and moisture enters this chamber, the moisture would settle to the bottom of the chamber and will complete the circuit between the moisture detectors.

This circuit must be connected to a sensing unit and signaling device. This is supplied in a Hydromatic® built control panel.

NOTE: Failure to install such a device negates all warranties by Hydromatic.

Pump:

Power cable is supplied with separate wire for ground. Be sure green wire is connected to a good ground such as water pipe or ground stake.

Heat Sensors:

All motors have heat sensor units embedded in the motor winding to detect excessive heat. The

sensors automatically reset when motor cools to safe temperature.

The sensors are connected in series with the motor starter coil so that the starter is tripped if heat sensor opens. The motor starter is equipped with overload heaters so all normal overloads are protected by the starter.

IMPORTANT: If Hydromatic electrical starting equipment is not supplied, the heat sensor circuit must be connected in series with the starter coil or warranty is void.

Once sensor resets, the starter is to be automatically reset for FM for continued operation of the pump. This circuitry is supplied in a Hydromatic control panel.

Power Cords:

The power cord and heat sensor seal failure cord are potted into the connection box cap. The cords must not be spliced.

NOTE: Each cable has a green lead. This is the ground wire and must be grounded properly per NEC and/or local codes. Cords should be inspected for abnormal wear and replaced accordingly.

Sump Level Control:

Sump level is controlled by Hydromatic float switch controls. The float is held in position in the sump by a weight attached to the power cord above the float. The cord supports the float and is adjusted for height from the surface.

Typical duplex systems use three controls: one set at turn-off, one set at turn-on for one pump, and one set for turn-on for two pumps. Pumps alternate operation on each successive cycle.

Two pumps operate together only if sump level rises to the third or override control. The override control also brings on the second pump in case of failure of the first

pump. Extra floats with appropriate controls can be supplied for alarm functions. Triplex systems use four controls: one set at turn-off, one set at turn-on for one pump, one set at turn-on for two pumps, and one set at turn-on for three pumps. Pumps alternate each successive cycle.

Three pumps operate together only if sump level rises to the fourth control (second override). This control also brings on the third pump in case of failure of either or both of the first two pumps.

Alarm Controls:

The alarm level is usually set above the override level so the alarm will signal only if the override level is exceeded. However, some engineers prefer to have the alarm level set below the override level as it is possible for one pump to fail and the other pump to operate on the override level with the sump level never reaching the alarm level. This is particularly true in cases of low inflow capacity.

Electrical Control Panel:

It is recommended that the Hydromatic® control panel be used with all pumps as proper starter heaters and connections for heat sensor wires are furnished.

The electrical equipment includes a main circuit breaker for each pump, a magnetic starter with overload protection for each pump, an H-O-A switch and run light for each pump, an electric alternator and a transformer to provide appropriate control circuit and alarms.

Overload Heaters:

If the Hydromatic electrical panel is not used, starters with 3 leg overload protection must be supplied. The heaters must be sized in accordance with the nameplate amps on the motor housing. The amp draw on these submersible motors is slightly higher than a corresponding horsepower surface motor, so heaters must be sized by the nameplate rating.

IMPORTANT: Be sure the heat sensor wires are connected in series with the starter coil circuit.

Pump Installation

Installing Pump in Sump:

Before installing pump in sump, lay it on side and turn impeller manually. Impeller may be slightly stuck due to factory test water, so it must be broken loose with small bar or screwdriver in edge of vanes. The impeller should turn freely.

Clean all trash and sticks from sump and connect pump to piping.

A check valve must be installed on each pump. A gate or plug valve in each pump discharge line is also recommended. This valve should be installed on the discharge side of the check valve so if necessary to service the check valve, the line pressure can be cut off. Single pump systems are sometimes installed without a check valve where it is desirable to self-drain the discharge line to

prevent freezing. This can be done only with short discharge lines, otherwise water will return to the sump and cause short cycling of the pump.

Installing Sump Level Control Float Controls:

In either simplex, duplex or triplex systems the lower or turn-off control is to be set to maintain a minimum level in the sump. This level shall be no more than 3-1/4" from the top of the motor housing down to the surface of the sewage.

The second or turn-on control is set above the lower turn-off control. The exact distance between the two floats must be a compromise between a frequent pumping cycle (10 starts per hour max.) to control septicity, solids and a slower cycle for energy economy. This distance should be determined by the engineer or consulting engineer depending on the conditions of the application.

For installation of Hydromatic supplied level controls, refer to your systems installation and service manual.

NEMA 4 Junction Box (Optional):

If electrical control panel is to be set remote from the pump sump a NEMA 4 junction box should be used to make power and control connections. The Hydromatic NEMA 4 junction box is provided with compression connectors for sealing all wires. No sealing compound is needed to make connections waterproof.

Wiring diagrams are provided with panel for making connections.

NUMBER OF CONDUCTORS REQUIRED BETWEEN CONTROL PANEL AND NEMA 4 JUNCTION BOX

Power lines and control wires can be carried in conduit or can be underground buried cable.

System Type	Number of Control Wires	Number of Power Lines	Number of Ground Wires #8	HEAT SENSOR & SEAL FAILURE	
				Number of Sensor Wires	Number of Ground Wires
Simplex	3	3	1	3	1
Simplex with Alarm	5	3	1	3	1
Duplex	5	6	1	6	2
Duplex with Alarm	7	6	1	6	2

The size wire to use from panel to sump depends on motor size and distance in feet.

Be sure each wire is checked out so that a wrong connection will not be made. An ohmmeter or Megger can be used to check wire continuity.

Installing Float Switch Controls:

The controls are supported by a mounting bracket that is attached to sump wall or cover or to the NEMA 4 junction box.

Cord snubbers are used to hold the cord in place. Control lever can be changed at any time by loosening the snubber and readjusting cord length.

In either simplex or duplex system the lower or turn-off control is set just above the top of volute so that the volute will always be submerged during the pumping cycle. The second or turn-on control is set about 24 inches above the lower turn-off control.

More distance between turn-on and turn-off controls can be used, but sewage may become septic and excessive solids may collect for the pump to handle. A frequent pumping cycle is recommended for best operation.

If an alarm system is used, this control is usually set about 6 inches above the override control.

Making Electrical Connections:

All electrical wiring must be in accordance with the local code, and only competent electricians should make the installations. Complete wiring diagrams are on the inside cover of the panel. All wires should be checked for ground with an ohmmeter or Megger after the connections are made. *This is important, as one grounded wire can cause considerable trouble.*

IMPORTANT: If equipment is not properly wired and protected as recommended, the warranty is void.

Heat Sensors and Seal Failure Connections:

Be sure that heat sensor wires are connected in series with the starter coil. Connections are provided on the terminal strip.

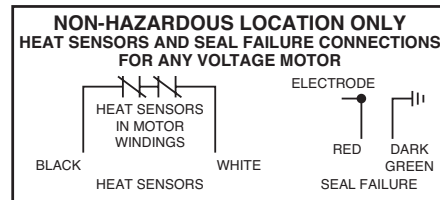
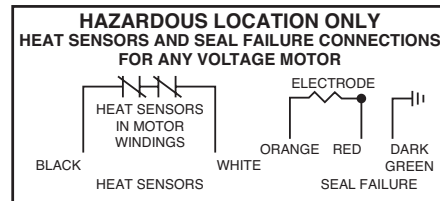
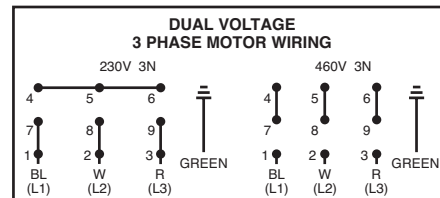

Pump Operations

Starting System:

1. Turn H-O-A switch to Off position, then turn on main circuit breakers.
2. Open all discharge valves and allow water to rise in sump pump.
3. Turn H-O-A switch to Hand position on one pump and notice operation. If pump is noisy and vibrates, rotation is wrong. To change rotation interchange any two line leads to motor on 3 ϕ only. **DO NOT INTERCHANGE MAIN INCOMING LINES.** If duplex system, check second pump in the same manner.
4. Now set both H-O-A switches to Auto position and allow water to rise in sump until one

pump starts. Allow pump to operate until the level drops to turn-off point.

5. Allow sump level to rise to start other pump. Notice run lights on panel; pumps should alternate on each successive cycle of operation.
6. Turn both H-O-A switches to Off position and allow sump to fill to the override control level.
7. Turn both switches to Auto position and both pumps should start and operate together until level drops to turn-off point.
8. Repeat this operation cycle several times before leaving the job.
9. Check voltage when pumps are operating and check the amp draw of each pump. Check amps on each wire as sometimes a high leg will exist. One leg can be somewhat higher, 5 to 10%, without causing trouble. For excessive amp draw on one leg, the power company should be consulted.

Phase Converters:

Phase converters are generally not recommended, but in cases where only single phase current is available phase converter can be used. Be sure to size the phase converter large enough for the amp draw specified on the motor nameplate, not necessarily by motor horsepower. The warranty on all three phase submersible motors is void if operated with single phase power through a phase converter and 3 leg ambient compensated extra-quick trip overload protectors are not used.

Pump Maintenance

NOTE: Any unauthorized field repair voids the warranty, the hazardous location rating, and Factory Mutual approval.

If the heat sensor and seal failure are hooked up properly, no attention is necessary as long as the seal failure indicator light doesn't come on. To ensure continuity of the seal sensor leads, a test light is provided on intrinsically safe Hydromatic® panels as standard equipment.

Pump should be checked every quarter for corrosion and wear.

Maintenance:

As the motors are oil filled, no lubrication or other maintenance is required.

If the pump is used on a rail system, it should be lifted once every six months and checked for corrosion and wear.

Generally these pumps give very reliable service and can be expected to operate for years on normal sewage pumping without failure.

Lightning:

In some areas where considerable lightning occurs, it is recommended that a lightning arrestor be installed at the control panel to aid against damage to the motor.

Field Service on Hydromatic Hazardous Location Pumps:

If a Hydromatic hazardous location pump is used in a hazardous location, or if the pump is still in warranty, the pump must be returned to the factory for service or repaired at an authorized Factory Mutual Hydromatic service center. Charges will not be allowed if in warranty pump is not taken to an authorized Factory Mutual Hydromatic service center. This will ensure the integrity of

the hazardous location rating of the pump and comply with our warranty requirements.

Field Service on Motor:

All submersible motors out of warranty can be serviced in the field by any reliable motor service shop. Any pump, in warranty, must be returned to the factory for service or repaired at an authorized Hydromatic service center. Charges will not be allowed if in warranty pump is not taken to an authorized Hydromatic service center.

When field service is performed on a pump, these instructions should be carefully followed.

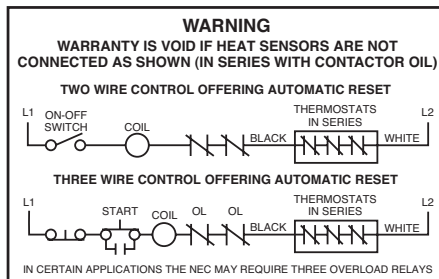

Replacing Stator:

1. If stator only is damaged, it may not be necessary to completely dismantle pump as stator and housing can be lifted from pump without disturbing seals or bearings.
2. Drain all oil from upper housing, remove drain plug in bottom of stator housing and remove plug in top of housing to allow air to enter.
3. After chamber is drained, remove hold-down bolts and lift off. Use care in lifting as the seal failure connecting wire must be disconnected before housing is completely removed.
4. Set assembly on bench and remove connection box. When box is lifted off, connection wires to motor will be exposed. These wires will probably be burned, but each wire is tagged with a metal marker giving wire number. Cut the wires.

If the leads to the connection box are burned, a complete new connection box with new wire must be used. The wires are potted in with sealing compound and a new unit must be obtained from the factory.

5. The stator is held in the housing with a bolted-in end ring and an outside locking screw to prevent stator from turning.
6. After ring is removed, turn housing upright and bump on hardwood blocks. This should jar the stator loose and allow it to drop out.
7. Thoroughly clean housing before replacing new stator. Replace stator and make all wire connections to connection box before replacing housing on pump. This is important as leads must be tucked behind the windings by using hands up through rotor core.

IMPORTANT: Use only compression type insulated connectors on the wires.

DO NOT TAPE LEADS AS OIL WILL DETERIORATE THE TAPE AND CAUSE DAMAGE TO STATOR AND BEARINGS.

8. Drain oil from seal chamber. Check top bearing. If clean and does not turn rough, bearings can be reused and it is not necessary to completely dismantle pump to change bearings. If bearings are damaged with dirt or heat, they must be replaced. Remember to reinstall the upper bearing load spring.
9. Before replacing stator housing be sure outside lock screw is in place and that O-ring is used under head of bolt. A leak here can cause a motor failure.

10. Replace stator housing onto seal chamber and bolt in place. **Be sure seal failure wire is connected before housing is assembled.**
Be sure back-off screws have been loosened so that parts can come metal to metal. Be sure O-ring seal has been replaced. If O-ring is nicked or cut, replace with new rings. This applies to all O-rings used in assembly.
11. After all leads are reconnected in the connection box, make a high voltage ground test on each wire. The only wire that should show ground is the green power lead and the ground lead in the auxiliary control cable.
12. For safety, complete pump should be air checked under water for leaks. Lay pump on side for this oil filling with oil fill hole upright. Do not completely fill; leave oil about 1 inch below plug hole. Use only Hydromatic® submersible oil in this chamber. Replace plug; use Permatex on threads. Install air valve in top plug opening of motor housing and charge housing with about 10 psi of air. Be sure air is dry. Do not use air line where water may be trapped in the line. Submerge complete unit under water and check for leaks.
13. Refill motor chamber with Hydromatic submersible oil. Fill chamber until oil covers top of the windings. Leave air space in the top for expansion. Use Permatex on plug threads.

Replacing Seals and Bearings:

1. Drain all oil from motor chamber and seal chamber as described.
2. Remove the motor housing as described.

3. Remove bolts that hold seal chamber to pump housing. Use back-off screws to break loose. With hardwood block, tap end of impeller to loosen from shaft. When free, remove impeller from shaft.
4. Lift rotating assembly (rotor, shaft and impeller) from pump case and place horizontally on bench.
5. Remove screw and washer from end of shaft and then screw socket head bolt back into shaft. Using a screwdriver on opposite sides behind impeller apply force, then tap on end of socket bolt to break impeller loose from taper shaft.
6. Remove key and then slide seal off the shaft.
7. To remove seal plate, take out socket head flat screws and using screws in back off holes, pry plate loose. This will also force seal off if not already removed.
8. Remove snap ring that holds upper seal. Pull seal if it is free. If not free, it can be forced off when shaft is removed.
9. Set assembly in upright position and bump end of shaft on hardwood block. This will push the bearing from the housing and will force upper seal from shaft.
10. Use bearing puller to remove bearings. Replace with new bearings. Press only on inner face of bearing when replacing. Pressing on outer face can damage the bearing.
IMPORTANT: Do not use any of the old seal parts. Replace with all new seals.
11. Thoroughly clean all castings before replacing seals. One grain of dirt between the seal faces can cause failure.

12. Examine all O-rings for nicks before using.
13. Use Loctite® on socket head locking screw in end of shaft.
14. Before refilling chamber with oil, air test as described above and refill both chambers with oil.
15. Always check all leads with high voltage or with Megger for grounds before operating the pump.

Replacing Cords:

The power cord and heat sensor - seal failure cord is potted into the connection box cap, forming the cord and cap assembly.

If cords require replacement due to damage or cords being too short, cord and cap assembly must be replaced as a complete assembly available from factory.

Check pump for proper rotation before returning to normal service.

Disconnecting Pump Cords:

If a Hydromatic hazardous location pump is to be removed from its location, the pump cords may be disconnected at control panel (on sump mounted control panels) and cord assembly taken with pump.

CAUTION: If cord openings from sump to control panel are open, gases from sump could enter panel and an explosive condition could exist.

Replacing Lower Seal, Impeller or Volute:

The wet end components may be repaired or replaced by an authorized Hydromatic service facility without compromising the hazardous location rating to the pump.

NOTE: Any time the seal is disturbed, it must be replaced.

Pump Troubleshooting

The following is a list of common problems and their probable causes.

Pump will not start.

1. No power to the motor. Check for blown fuse or open circuit breaker.
2. Selector switch may be in the Off position.
3. Control circuit transformer fuse may be blown.
4. Overload heater on starter may be tripped. Push to reset.

Pump will not start and overload heaters trip.

1. Turn off power and check motor leads with Megger or ohmmeter for possible ground.
2. Check resistance of motor windings. All 3 phases should show the same reading.
3. If no grounds exist and the motor windings check OK, remove pump from sump and check for clogged or blocked impeller.

Pump operates with selector switch in Hand position but will not operate in Auto position.

1. This indicates trouble in the float level control or the alternator relay.
2. Check control panel for trouble.

Pump runs but will not shut off.

1. Pump may be air locked. Turn pump off and let set for several minutes, then restart.
2. Lower float control may be hung-up in the closed position. Check in sump to be sure control is free.
3. Selector switch may be in the Hand position.

Pump does not deliver proper capacity.

1. Discharge gate valve may be partially closed or partially clogged.
2. Check valve may be partially clogged. Raise level up and down to clear.
3. Pump may be running in wrong direction. Low speed pumps can operate in reverse direction without much noise or vibration.
4. Discharge head may be too high. Check total head with gauge when pump is operating. Total head is discharge gauge pressure converted to feet plus vertical height from water level in sump to center line of pressure gauge in discharge line. Gauge should be installed on pump side of all valves. Multiply gauge pressure in pounds by 2.31 to get head in feet.
5. If pump has been in service for some time and capacity falls off, remove pump and check for wear or clogged impeller.

Motor stops and then restarts after short period but overload heaters in starter do not trip.

1. This indicates heat sensors in the motor are tripping due to excessive heat. Impeller may be partially clogged giving a sustained overload but not high enough to trip overload heater switch.
2. Motor may be operating out of liquid due to a failed level control.
3. Pump may be operating on a short cycle due to sump being too small or from water returning to sump due to a leaking check valve.

Wet End Components

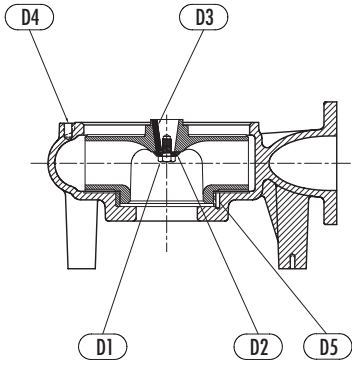

S4L(X)

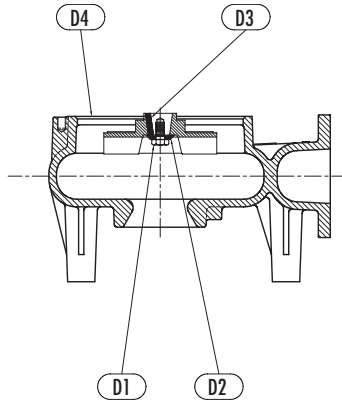

S4LRC

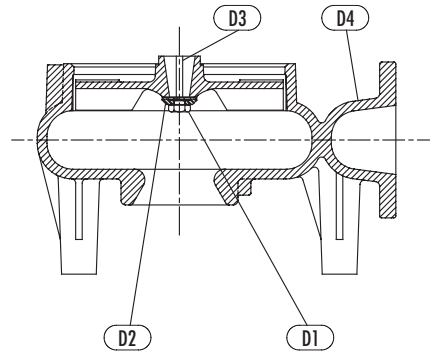

S4LVX

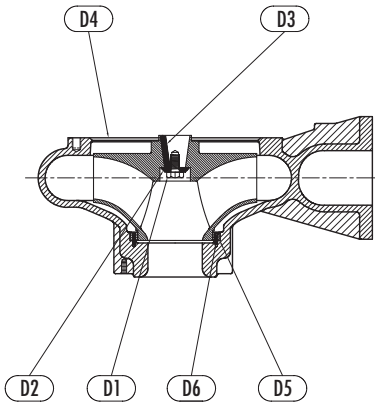

S4B(X)

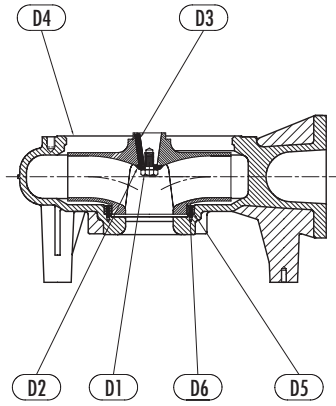

S4K(X)

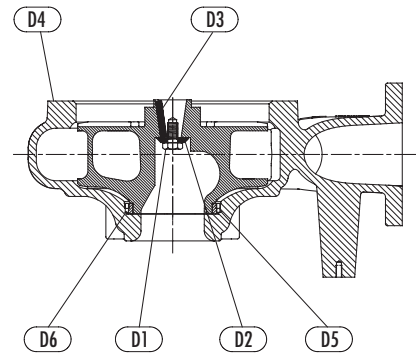

H4Q(X)

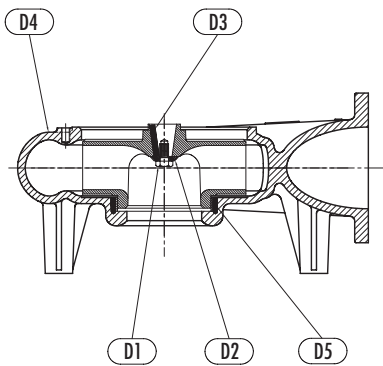

S6L(X)

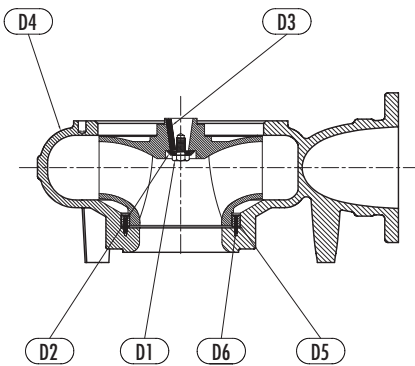

S6A(X)

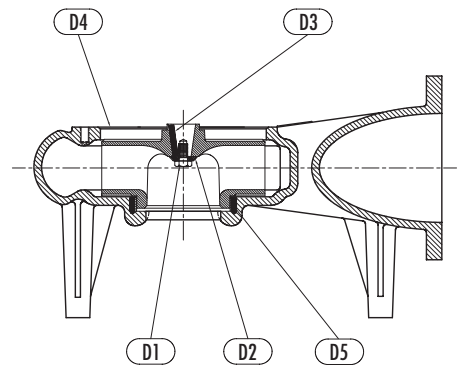

S8F(X)

Wet End Parts List For use with product built with USEM motor.

Item #	Description	S4B(X)	S4L(X)	S4LRC 3450 RPM	S4LRC/ S4LVX	S6A(X)	S6L(X)	S8F(X)	S4K(X)	H4Q(X)		
D1	SCREW – HHC 5/8-11 UNF x 1-1/4	005700181	005700181	005700181	005700181	005700181	005700181	005700181	005700181	005700181		
D2	WASHER – IMPELLER	019450001	019450001	019450001	019450001	019450001	019450001	019450001	019450001	019450001		
D3	KEY – 1/3" SQUARE	028550081	028550081	028550031	028550081	028550081	028550081	028550081	028550081	028550081		
D4	VOLUTE	136910002	089190015	107830002	107830002	136930012	089180015	089260025	137190002	151520015		
D5	RING – WEAR	136900003	042890023	REFER TO FACTORY	—	136950003	042890023	042890023	136900003	136900033		
D6	SCREW MACH.	048200101 (3)	—		—	048200111 (4)	—	—	—	048200101 (3)	000110021 (2)	
	IMPELLER	7.38"	—		110430162	—	—	—	—	—	—	
		7.88"	—		110430152	—	—	—	—	—	—	—
		8.38"	—		025940242	—	—	025940242	025940242	—	—	—
		8.63"	—		025940292	110430132	—	—	025940292	137200242	—	—
		8.81"	—		025940232	—	—	—	—	137200362	—	—
		9"	136920132		025940022	—	136940132	025940022	025940022	137200132	151510062	—
		9.25"	136920122		025940032	110430122	136940122	025940032	025940032	137200122	151510122	—
		9.5"	136920112		025940042	—	136940112	025940042	025940042	137200112	151510052	—
		9.63"	—		025940302	—	136940232	025940302	025940302	137200282	—	—
		9.81"	136920382		025940192	—	—	025940192	—	—	—	—
		10"	136920092		025940062	110430042	136940092	—	—	137200092	151510042	—
		10.18"	—		—	—	—	025940212	025940212	—	151510102	—
		10.25"	136920082		025940072	—	—	025940072	025940072	137200082	—	—
		10.31"	—		—	110430112	—	—	—	137200342	—	—
		10.38"	136920152		025940162	—	136940182	025940162	025940162	137200212	—	—
		10.5"	136920072		025940082	—	136940072	025940082	025940082	137200072	151510032	—
		10.85"	—		025940492	—	—	025940492	025940492	—	—	—
		11"	136920052		025940102	—	136940052	025940102	—	137200052	151510022	—
		11.25"	136920042		025940422	110430082	136940042	025940112	025940112	137200042	151510092	—
		11.38"	136920182		025940202	—	136940292	025940202	025940202	137200322	151510162	—
		11.5"	136920032		025940122	110430012	136940032	025940122	025940122	137200032	151510012	—
		11.63"	136920202		025940182	—	136940332	025940122	025940122	137200172	151510182	—
		11.88"	136920232		025940002	—	—	025940002	025940002	137200302	—	—
		12"	136920012		025940352	110430002	136940012	025940352	025940352	137200012	151510002	—

Standard Location S4L, S4LRC, S4B, S4K, H4Q, S6L, S6A and S8F Motor End Components

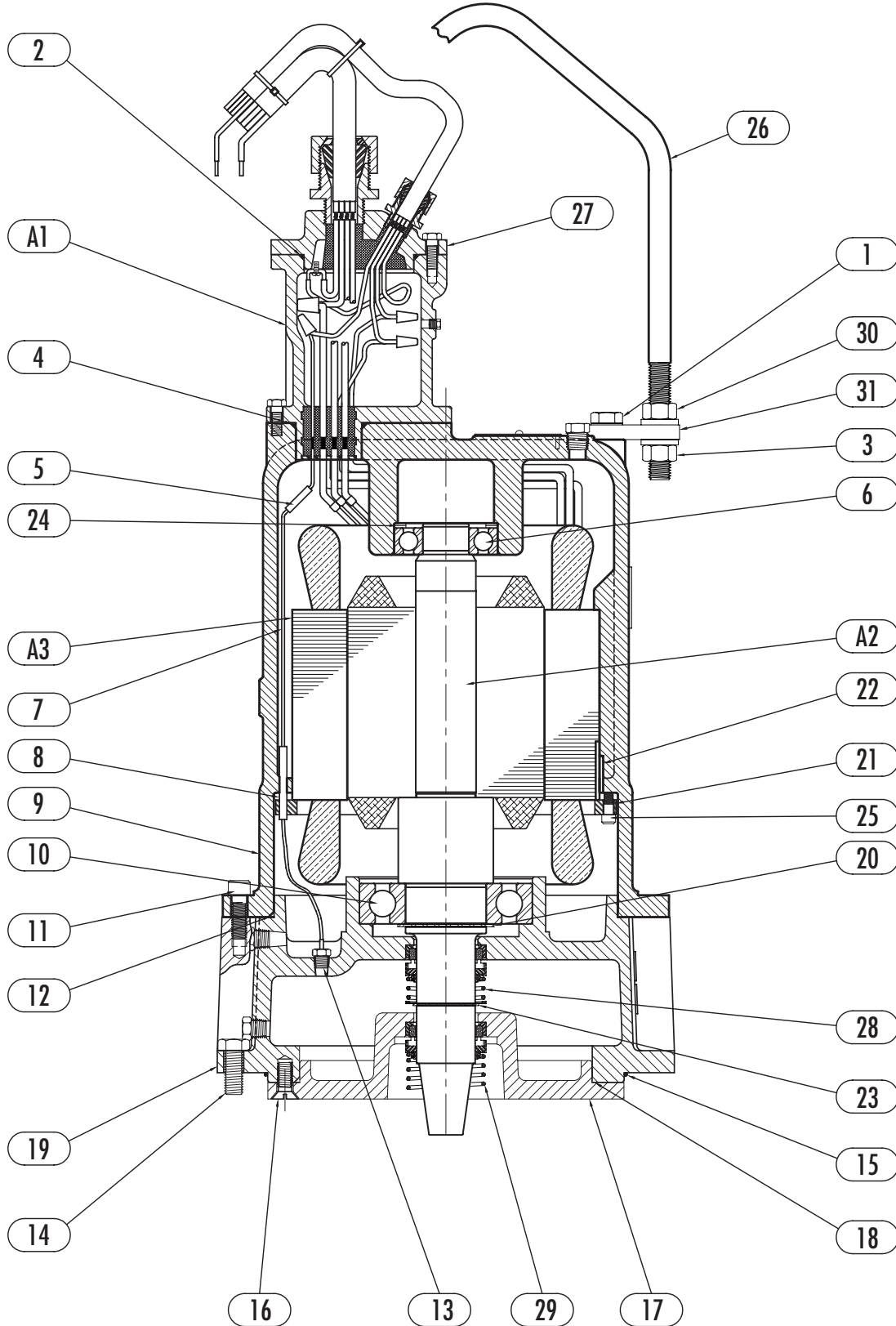

Standard Location S4L, S4LRC, S4B, S4K, H4Q, S6L, S6A and S8F Motor End Parts List

For use with product built with USEM motor.

Ref. No.	Part No.	Part Description	Qty.
1	05454A027	WASHER – LOCK 5/8 SST	2
2	001500121	O-RING – 1/8 x 3.374 I.D. SC	1
3	05454A030	WASHER – LOCK 3/4 SST	4
4	001500071	O-RING – 1/8 x 7.234 I.D. SC	1
5	12672A001	CONNECTOR – WIRE	3
6	08565A027	BEARING – BALL – UPPER	1
7	060000211	WIRE W/TERMINAL	1
8	012720001	TUBING – INSULATING	1
9	048320032	HOUSING – MOTOR	1
10	000650321	BEARING – BALL – LOWER	1
11	005680061	SCREW – HHC 1/2-13 x 1-1/2	8
12	001500251	O-RING – 1/8 x 11.484 I.D. SC	1
13	084720035	SEAL FAILURE ASSY.	1
14	19105A033	SCREW – HHC 5/8-11 x 1-1/2	8
15	001500261	O-RING – 1/8 x 11.984 I.D. SC	1

Ref. No.	Part No.	Part Description	Qty.
16	029210011	SCREW – HHC 1/2-13 x 1-1/4	4
17	025960032	PLATE – SEAL	1
18	001500401	O-RING – 1/8 x 9.734 I.D. SC	1
19	025950042	HOUSING – BEARING/SEAL	1
20	009750251	RING – RETAINING	1
21	026030003	RING – STATOR RETAINING	1
22	065790031	KEY SQ – 1/4" x 1.19	1
23	009750061	RING – RETAINING	1
24	000640061	SPRING – BEARING ADJ.	2
25	001780051	SCREW – HEX SOC. 5/16 x 1-1/2	8
26	151751001	LIFTING BAIL	1
27	152770305	35' CORD ASSEMBLY – 10-4	1
	152770315	35' CORD ASSEMBLY – 8-4 500W	1
	152770325	35' CORD ASSEMBLY – 8-4	1
	152770335	35' CORD ASSEMBLY – 6-4	1

Ref. No.	Part No.	Part Description	Qty.
	152770345	35' CORD ASSEMBLY – 4-4	1
	152770355	35' CORD ASSEMBLY – 2-4	1
28	019570001	CARBON CERAMIC/BUNA-N – UPPER S	1
29	019570001	CARBON CERAMIC (STD)/BUNA-N – LOWER S	1
	019570021	CARBIDE (OPT) – LOWER C	1
30	19109A080	NUT – HEX 3/4 SST	4
31	151740001	BRACKET – MOUNTING	2

Notes: S – Parts in Seal Kit C – Parts in Carbide Seal Kit – Fill oil to above the motor windings.

Motor Parts List

For use with product built with USEM motor.

hp	VOLTAGE/ ph/RPM	A1 BOX CONNECTION	A2 ROTOR/ SHAFT	A3 STATOR R	RING SPACER
3-5	200/3/870	062370015	143990115	143992031	076650011
3-5	230-460/3/870	062370005	143990115	143990031	076650011
3-5	575/3/870	062370015	143990115	143996031	076650011
3-5	200/3/1150	062370015	144000115	144002031	076650121
3-5	230-460/3/1150	062370005	144000115	144000031	076650121
3-5	575/3/1150	062370015	144000115	144006031	076650121
7.5-10	200/3/1150	062370015	141500115	141502031	076650101
7.5-10	230-460/3/1150	062370005	141500115	141500031	076650101
7.5-10	575/3/1150	062370015	141500115	141506031	076650101
15	200/3/1150	062370035	141510115	151512031	076650051
15	230/3/1150	062370055	141510115	141510031	076650051
15	460/3/1150	062370005	141510115	141510031	076650051
15	575/3/1150	062370015	141510115	141516031	076650051
20	200/3/1750	062370035	141520115	141522031	076650041
20	230-460/3/1750	062370005	141520115	141520031	076650041
20	575/3/1750	062370015	141520115	141526031	076650041
25-30	200/3/1750	062370075	141530115	141532031	–
25-30	230/3/1750	062370055	141530115	141530031	–
25-30	460/3/1750	062370005	141530115	141530031	–
25-30	575/3/1750	062370015	141530115	141536031	–
40	230/3/1750	062370075	141530115	141540031	–
40	460/3/1750	062370005	141530115	141540031	–
40	575/3/1750	062370015	141530115	141546031	–
50	460/3/1750	062370055	141530115	141550031	–
50	575/3/1750	062370035	141530115	141556031	–
60	460/3/3450	062370075	143030115	143030031	076650011
60	575/3/3450	062370035	143030115	143036031	076650011

Fill oil to above the motor windings.

Hazardous Location S4LX, S4LVX, S4BX, S4KX, H4QX, S6LX, S6AX and S8FX Motor End Components

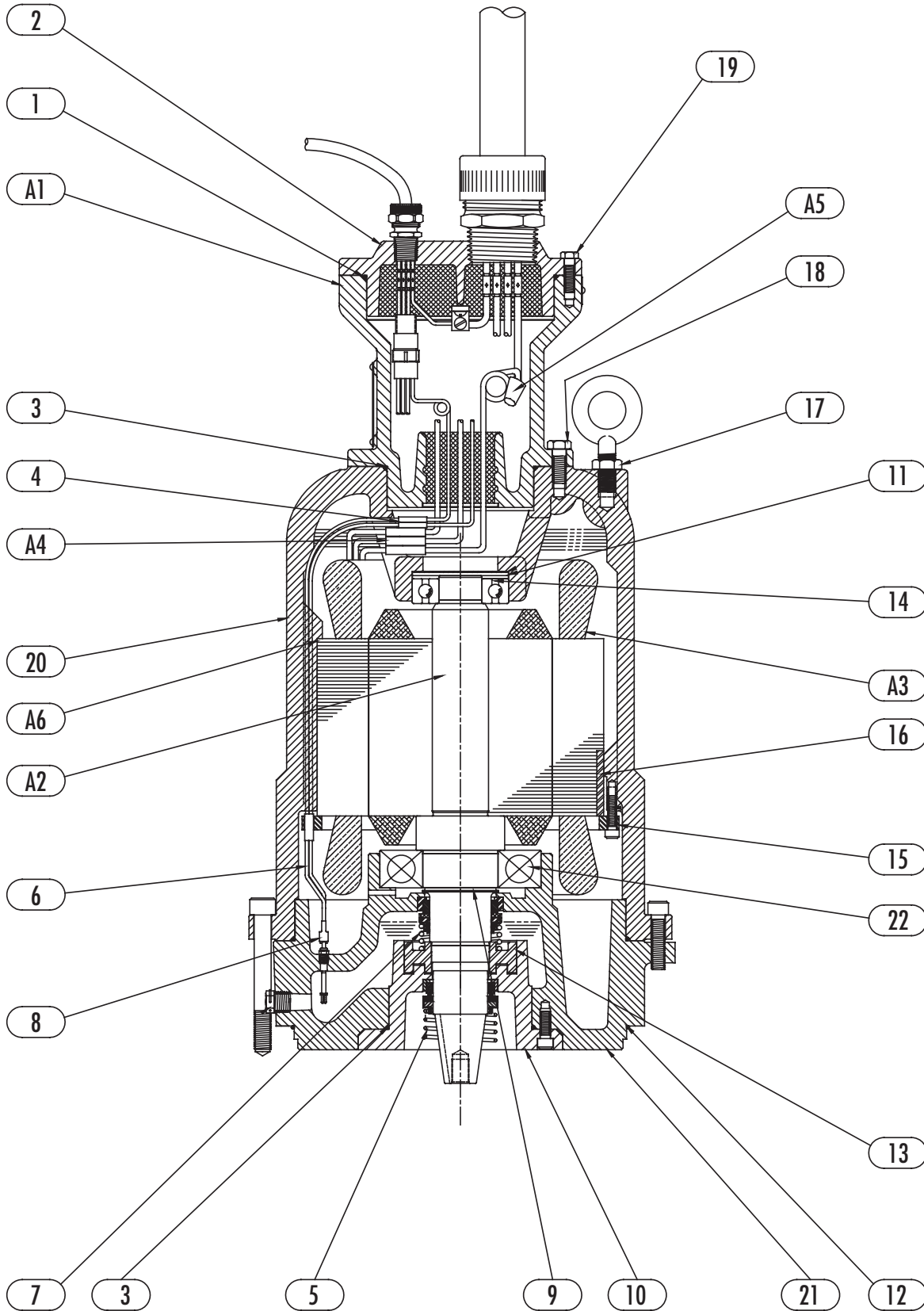

Hazardous Location S4LX, S4LVX, S4BX, S4KX, H4QX, S6LX, S6AX and S8FX Motor End Parts List

For use with product built with USEM motor.

Ref. No.	Part No.	Part Description	Qty.
1	001500191	O-RING 1/8 x 6.734 I.D.	1
2	152790305	35' CORD ASSEMBLY – 10-4	1
	152790315	35' CORD ASSEMBLY – 8-4 SOOW	1
	152790325	35' CORD ASSEMBLY – 8-4 W	1
	152790335	35' CORD ASSEMBLY – 6-4	1
	152790345	35' CORD ASSEMBLY – 4-4	1
	152790355	35' CORD ASSEMBLY – 2-4	1
3	001500361	O-RING – 1/8 x 5.234 I.D.	2
4	108980001	CONNECTOR – ELECTRIC	4
5	019570001	LOWER SEAL – CARBON CERAMIC	1
	019570021	LOWER SEAL – TUNGSTEN CARBIDE	1
6	109000035	SEAL FAILURE ASSY.	1
7	080730001	UPPER SEAL – CARBON CERAMIC	1

Ref. No.	Part No.	Part Description	Qty.
8	109010001	TERMINAL – HERMETIC	2
9	009750251	RING – RETAINING (LOWER BRG.)	1
10	107550012	PLATE – SEAL	1
11	000640051	SPRING – BEARING ADJ.	2
12	001500261	O-RING – 1/8 x 11.984 I.D.	2
13	107820033	RING – LABYRINTH	1
14	08565A027	BEARING – BALL	1
15	026030003	RING – STATOR	1
16	065790031	KEY – 1/4 SQUARE	1
17	011240021	NUT – HEX 5/8-11	0
18	19103A043	SCREW – HHC 1/2-13 UNC 1-1/4	4
19	19101A017	SCREW – HHC 3/8-16 UNC 1-1/4	6
20	107810052	HOUSING – MOTOR	1

Ref. No.	Part No.	Part Description	Qty.
21	107450012	HOUSING – BEARING	1
22	000650321	BEARING – BALL	1
	517000787	CARBON CERAMIC SEAL KIT	
	517003777	TUNGSTEN CARBIDE SEAL KIT	

6-Pole 1150 RPM

Item	6Pole 1150RPM Description	3 – 5 hp 200/3/1150	3 – 5 hp 230-460/3/1150	3 – 5 hp 575/3/1150	7.5 – 10 hp 200/3/1150	7.5 – 10 hp 230-460/3/1150	7.5 – 10 hp 575/3/1150	15 hp 200/3/1150	15 hp 230/3/1150	15 hp 460/3/1150	15 hp 575/3/1150
A1	Connection Box	114080005	114080015	114080005	114080005	114080015	114080005	114080025	114080035	114080015	114080005
A2	Rotor/Shaft Assy	143990125	143990125	143990125	143990125	143990125	143990125	141510125	141510125	141510125	141510125
A3	Stator	144002031	144000031	144006031	141502031	141500031	141506031	141512031	141510031	141510031	141516031
A4	Connector (stator to conn. box)	116750001(2)	116750001(2)	116750001(2)	116750001(2)	116750001(2)	116750001(2)	116750001(2)	116750001(2)	116750001(2)	116750001(2)
		116910001(3)	116910001(9)	116910001(3)	116910001(3)	116910001(9)	116910001(3)	116910001(3)	116910001(3)	116910001(9)	116910001(3)
		151550011(2)	151550011(2)	151550011(2)	151550011(2)	151550011(2)	151550011(2)	151550011(2)	151550011(2)	151550011(2)	151550011(2)
		108980001(2)	108980001(2)	108980001(2)	108980001(2)	108980001(2)	108980001(2)	108980001(2)	108980001(2)	108980001(2)	108980001(2)
A5	Connector (box to cord cap)	024930001(3)	024930001(3)	024930001(3)	024940001(3)	024940001(3)	024930001(3)	024980071(3)	024940001(3)	024930001(3)	024930001(3)
A6	Spacer	076650121	076650121	076650121	076650101	076650101	076650101	076650051	076650051	076650051	076650051
	Insulator Split Bolt	—	—	—	—	—	—	086750011(3)	—	—	—

8-Pole 870 RPM

Item	8Pole 870 RPM Description	3 – 5 hp 200/3/870	3 – 5 hp 230-460/3/870	3 – 5 hp 575/3/870	7 hp 200/3/870	7 hp 230-460/3/870	7 hp 575/3/870
A1	Connection Box	114080005	114080015	114080005	114080005	114080015	114080005
A2	Rotor/Shaft Assy	143990125	143990125	143990125	143990125	143990125	143990125
A3	Stator	143992031	143990031	143996031	144022031	144020031	144026031
A4	Connector (stator to conn. box)	116750001(2)	116750001(2)	116750001(2)	116750001(2)	116750001(2)	116750001(2)
		116910001(3)	116910001(9)	116910001(3)	116910001(3)	116910001(3)	116910001(3)
		151550011(2)	151550011(2)	151550011(2)	151550011(2)	151550011(2)	151550011(2)
		108980001(2)	108980001(2)	108980001(2)	108980001(2)	108980001(2)	108980001(2)
A5	Connector (box to cord cap)	024930001(3)	024930001(3)	024930001(3)	024940001(3)	024940001(3)	024930001(3)
A6	Spacer	076650011	076650011	076650111	076650101	076650101	076650101

Hazardous Location S4LX, S4LVX, S4BX, S4KX, H4QX, S6LX, S6AX and S8FX Motor End Parts List (Continued)

For use with product built with USEM motor.

4-Pole 1750 RPM

Item	4Pole 1750 RPM Description	10 hp 200/3/1750	10 hp 230-460/3/1750	10 hp 575/3/1750	15 hp 200/3/1750	15 hp 230/3/1750	15 hp 460/3/1750
A1	Connection Box	114080005	114080015	114080005	114080025	114080035	114080015
A2	Rotor/Shaft Assy	141510125	141510125	141510125	141520125	141520125	141520125
A3	Stator	141522031	141520031	141526031	141522031	141520031	141520031
A4	Connector (stator to conn. box)	116750001(2)	116750001(2)	116750001(4)	116750001(2)	116750001(2)	116750001(2)
		23394A001(3)	116910001(9)	116910001(3)	23394A001(3)	116910001(9)	116910001(9)
		151550011(2)	151550011(2)	151550011(4)	151550011(2)	151550011(2)	151550011(2)
		108980001(2)	108980001(2)	—	108980001(2)	108980001(2)	108980001(2)
A5	Connector (box to cord cap)	024940001(3)	024940001(4)	024930001(3)	024980051(3)	024940001(1)	024940001(6)
		—	—	—	—	024980041(3)	—
A6	Spacer InsulatorSplit Bolt	076650041	076650041	076650041	076650041	076650041	076650041
		—	—	—	086750021(3)	086750021(3)	—

4-Pole 1750 RPM

Item	4Pole 1750 RPM Description	15 hp 575/3/1750	20 hp 200/3/1750	20 hp 230/3/1750	20 hp 460/3/1750	20 hp 575/3/1750	25 hp 200/3/1750	25 hp 230/3/1750
A1	Connection Box	114080005	114080025	114080035	114080035	114080005	114080045	114080055
A2	Rotor/Shaft Assy	141520125	141520125	141520125	141520125	141520125	141530125	141530125
A3	Stator	141526031	141522031	141520031	141520031	141526031	141532031	141530031
A4	Connector (stator to conn. box)	116750001(2)	116750001(2)	116750001(2)	116750001(2)	116750001(2)	116750001(2)	116750001(2)
		116910001(3)	23394A001(3)	116910001(9)	116910001(9)	116910001(3)	23394A001(3)	116910001(9)
		151550011(2)	151550011(2)	151550011(2)	151550011(2)	151550011(2)	151550011(2)	151550011(2)
		108980001(2)	108980001(2)	108980001(2)	108980001(2)	108980001(2)	108980001(2)	108980001(2)
A5	Connector (box to cord cap)	024930001(3)	024980071(3)	024940001(1)	024940001(6)	024930001(3)	024980071(3)	024980071(3)
		—	—	024980051(3)	—	—	—	024980041(1)
A6	Spacer InsulatorSplit Bolt	076650041	0766500418	0766500418	0766500418	0766500418	—	—
		—	06750011(3)	086750021(3)	—	—	086750011(3)	086750011(3)
		—	—	—	—	—	—	086750021(1)

4-Pole 1750 RPM

Item	4Pole 1750 RPM Description	25 hp 460/3/1750	25 hp 575/3/1750	30 hp 200/3/1750	30 hp 230/3/1750	30 hp 460/3/1750	30 hp 575/3/1750	40 hp 200/3/1750
A1	Connection Box	114080015	114080005	114080045	114080055	114080035	114080005	114080065
A2	Rotor/Shaft Assy	141530125	141530125	141530125	141530125	141530125	141530125	141530125
A3	Stator	141530031	141532031	141532031	141530031	141530031	141536031	141542031
A4	Connector (stator to conn. box)	116750001(2)	116750001(2)	116750001(2)	116750001(2)	116750001(2)	116750001(2)	116670001(2)
		116910001(9)	116910001(3)	23394A001(3)	23394A001(9)	116910001(9)	116910001(3)	116910001(9)
		151550011(2)	151550011(2)	151550011(2)	151550011(2)	151550011(2)	151550011(2)	151550011(2)
		—	—	—	—	—	—	151550031(3)
A5	Connector (box to cord cap)	024940001(6)	024940001(3)	024980071(3)	024980071(3)	024940001(6)	024940001(3)	024980071(3)
		—	—	—	024980041(1)	—	—	—
A6	Spacer InsulatorSplit Bolt	—	—	—	—	—	—	—
		—	—	086750011(3)	086750011(3)	—	—	086750011(3)
		—	—	—	086750021(1)	—	—	—

4-Pole 1750 RPM

Item	4Pole 1750 RPM Description	40 hp 230/3/1750	40 hp 460/3/1750	40 hp 575/3/1750	50 hp 230/3/1750	50 hp 460/3/1750	50 hp 575/3/1750
A1	Connection Box	114080055	114080035	114080025	114080065	114080055	114080025
A2	Rotor/Shaft Assy	141530125	141530125	141530125	141530125	141530125	141530125
A3	Stator	141540031	141540031	141546031	141550031	141550031	141556031
A4	Connector (stator to conn. box)	116750001(2)	116750001(2)	116750001(2)	116750001(2)	116750001(2)	116750001(2)
		23394A001(9)	23394A001(9)	116910001(3)	116670001(3)	23394A001(9)	23394A001(3)
		151550011(2)	151550011(2)	151550011(2)	151550011(2)	151550011(2)	151550011(2)
		—	—	—	151550031(3)	—	—
A5	Connector (box to cord cap)	108980001(2)	108980001(2)	108980001(2)	108980001(2)	108980001(2)	108980001(2)
		024980071(3)	024940001(3)	024940001(3)	024980071(3)	024940001(3)	024940001(3)
A6	Spacer InsulatorSplit Bolt	024980041(1)	—	—	—	024980071(3)	—
		—	—	—	—	—	—
		086750011(3)	—	—	086750011(3)	086750011(3)	—
		086750021(1)	—	—	—	—	—

Wiring Diagrams

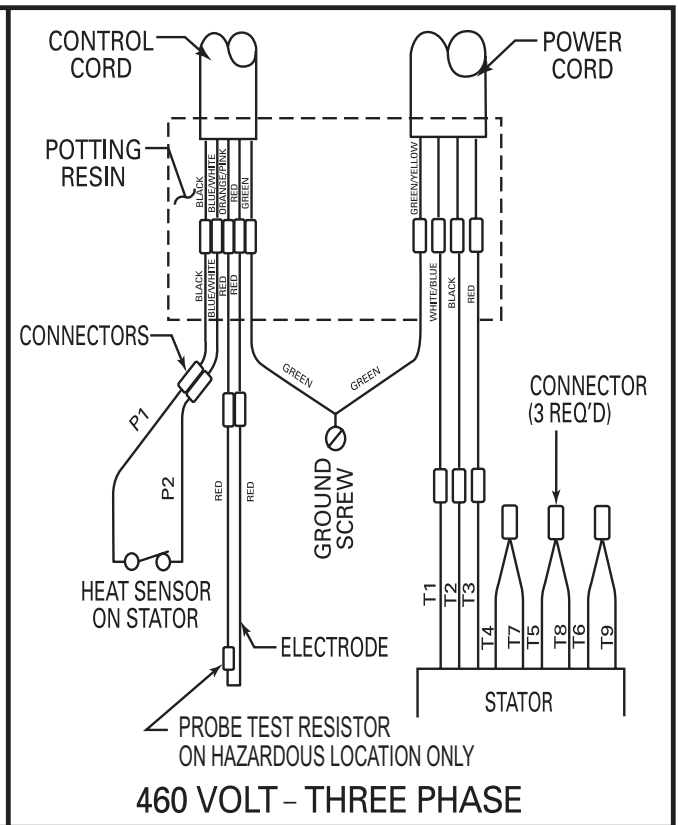
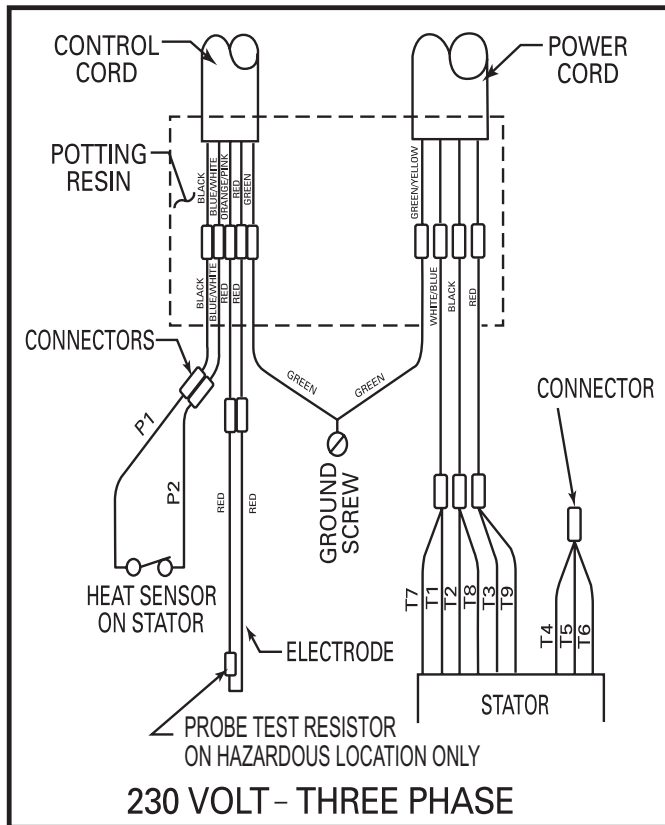
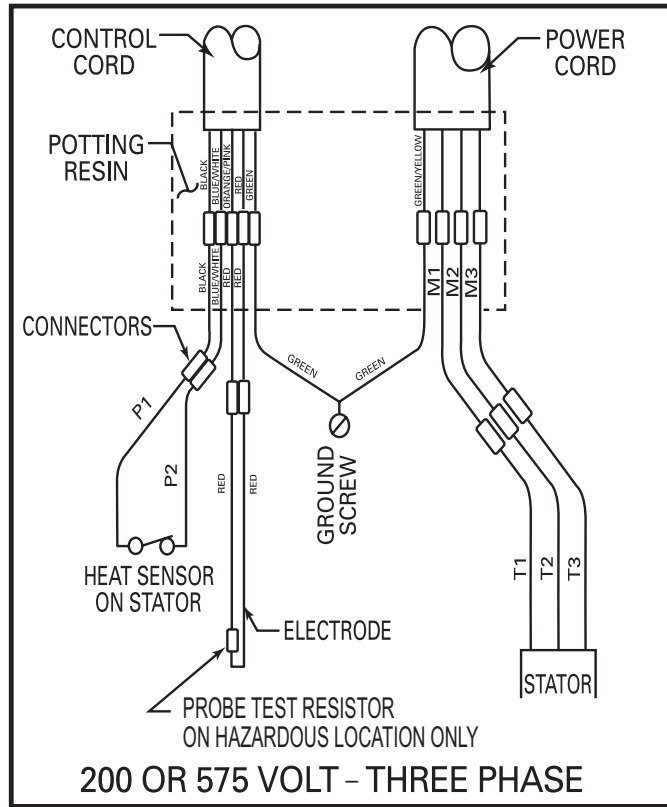

STANDARD LIMITED WARRANTY

Pentair Hydromatic® warrants its products against defects in material and workmanship for a period of 12 months from the date of shipment from Pentair Hydromatic or 18 months from the manufacturing date, whichever occurs first – provided that such products are used in compliance with the requirements of the Pentair Hydromatic catalog and technical manuals for use in pumping raw sewage, municipal wastewater or similar, abrasive-free, noncorrosive liquids.

During the warranty period and subject to the conditions set forth, Pentair Hydromatic, at its discretion, will repair or replace to the original user, the parts that prove defective in materials and workmanship. Pentair Hydromatic reserves the right to change or improve its products or any portions thereof without being obligated to provide such a change or improvement for prior sold and/or shipped units.

Start-up reports and electrical schematics may be required to support warranty claims. Submit at the time of start up through the Pentair Hydromatic website: <http://forms.pentairliterature.com/startupform/startupform.asp?type=h>. Warranty is effective only if Pentair Hydromatic authorized control panels are used. All seal fail and heat sensing devices must be hooked up, functional and monitored or this warranty will be void. Pentair Hydromatic will cover only the lower seal and labor thereof for all dual seal pumps. Under no circumstance will Pentair Hydromatic be responsible for the cost of field labor, travel expenses, rented equipment, removal/reinstallation costs or freight expenses to and from the factory or an authorized Pentair Hydromatic service facility.

This limited warranty will not apply: (a) to defects or malfunctions resulting from failure to properly install, operate or maintain the unit in accordance with the printed instructions provided; (b) to failures resulting from abuse, accident or negligence; (c) to normal maintenance services and parts used in connection with such service; (d) to units that are not installed in accordance with applicable local codes, ordinances and good trade practices; (e) if the unit is moved from its original installation location; (f) if unit is used for purposes other than for what it is designed and manufactured; (g) to any unit that has been repaired or altered by anyone other than Pentair Hydromatic or an authorized Pentair Hydromatic service provider; (h) to any unit that has been repaired using non factory specified/OEM parts.

Warranty Exclusions: PENTAIR HYDROMATIC MAKES NO EXPRESS OR IMPLIED WARRANTIES THAT EXTEND BEYOND THE DESCRIPTION ON THE FACE HEREOF. PENTAIR HYDROMATIC SPECIFICALLY DISCLAIMS THE IMPLIED WARRANTIES OF MERCHANTABILITY AND FITNESS FOR ANY PARTICULAR PURPOSE.

Liability Limitation: IN NO EVENT SHALL PENTAIR HYDROMATIC BE LIABLE OR RESPONSIBLE FOR CONSEQUENTIAL, INCIDENTAL OR SPECIAL DAMAGES RESULTING FROM OR RELATED IN ANY MANNER TO ANY PENTAIR HYDROMATIC PRODUCT OR PARTS THEREOF. PERSONAL INJURY AND/OR PROPERTY DAMAGE MAY RESULT FROM IMPROPER INSTALLATION. PENTAIR HYDROMATIC DISCLAIMS ALL LIABILITY, INCLUDING LIABILITY UNDER THIS WARRANTY, FOR IMPROPER INSTALLATION. PENTAIR HYDROMATIC RECOMMENDS INSTALLATION BY PROFESSIONALS.

Some states do not permit some or all of the above warranty limitations or the exclusion or limitation of incidental or consequential damages and therefore such limitations may not apply to you. No warranties or representations at any time made by any representatives of Pentair Hydromatic shall vary or expand the provision hereof.



HYDROMATIC®

740 EAST 9TH STREET
ASHLAND, OHIO, USA 44805
419-289-1144

490 PINEBUSH ROAD, UNIT #4
CAMBRIDGE, ONTARIO, CANADA N1T 0A5
800-363-PUMP

WWW.HYDROMATIC.COM