

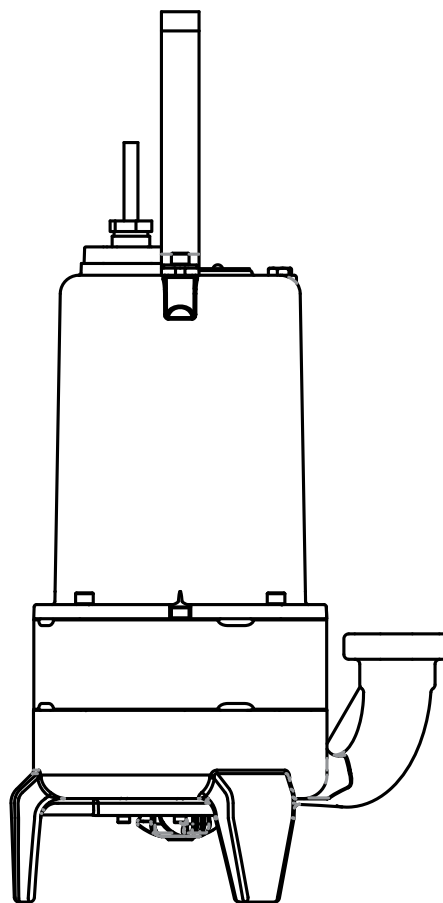

**HYDROMATIC®**



# HVR200 SERIES GRINDER PUMPS

## INSTALLATION AND SERVICE MANUAL



NOTE! To the installer: Please make sure you provide this manual to the owner of the equipment or to the responsible party who maintains the system.

## USAGE

The HVR200 Series is a submersible wastewater grinder pump designed specifically for individual residential and pressure sewer applications. The pumps are to be used for domestic sewage only and are not to be used for pumping commercial or industrial sewage such as from motels, schools, apartments, factories, etc. **THIS PUMP IS NOT FOR USE IN HAZARDOUS LOCATIONS!**

## INSPECTING PUMP

Before making any piping or electrical connections, check the pump for shipping damage or cracks. Using a flat screwdriver placed in the slot on the shaft end, turn shaft and impellers to be sure they are free. **DO NOT TURN IMPELLER WITH FINGERS AS EDGES ARE SHARP.**

## POWER SUPPLY

The HVR200 Series grinder pump should be connected only to a 230 volt, single-phase, 60 Hz power source. The pump will draw approximately 10.7 amperes at minimum flow and 15.0 full load amperes. The pump must be connected to a grounded power socket. **DO NOT** cut off the ground pin from the power cord plug.

## POWER CORD

A 20 foot power cord is attached to the grinder pump via two insulated quick-disconnect terminals and a ground terminal. To replace a cord, begin by slightly loosening cord nut in the cord cap plate. Remove cord cap plate from the motor housing and carefully pull the power leads up out of the motor housing and disconnect them from the motor leads. Disconnect the ground wire from the cap plate and continue to completely loosen the cord nut from the cap.

To install new cord, feed terminals through cord cap plate and reconnect power terminals. Reconnect ground terminal to the bottom side of the cap plate. Carefully feed wires back into the motor housing and fasten the cord cap plate to the motor housing. Lastly, tighten the cord nut into the cap plate. Tighten firm, do not overtighten.

The power cord should be replaced if it has been damaged in any way or the cord jacket has become brittle.

## MOTOR TYPE

The HVR200 Series grinder pump contains a 3/4 frame, 2 hp, single-phase, 60 Hz, 3450 rpm, capacitor start, capacitor run motor with Class F insulation and built-in, on-winding overload protection. Motor has upper and lower ball bearings and is oil-cooled and lubricated.

## ⚠ CAUTION!

**THE HVR200 SERIES GRINDER PUMP SHOULD NEVER BE WORKED ON WITHOUT FIRST DISCONNECTING THE POWER CORD.**

## OIL TYPE

The motor housing contains dielectric transformer oil to provide good heat transfer and lubrication of ball bearings; no other lubrication is required. Oil level may be checked by removing the plug from the top of the motor housing. The oil level should be filled to the bottom of the end shield. **Do not overfill with oil.** Only dielectric transformer oil obtained from a Hydromatic® authorized service center should be used.

## PUMP SWITCH INSTALLATION INSTRUCTIONS

**NOTE:** In accordance with third party approval, pump must be submerged a minimum of 10-9/16" from bottom of the legs on volute case during operation.

### Mounting the Switch

1. Determine pumping range for installation. Do not tether less than 3-1/2" from pipe.
2. Tighten strap around discharge pipe keeping switch cable between strap and pipe to prevent slippage.
3. Space small ties at least 1" apart. To readjust ties, press small tie tabs down.
4. To lock releasable tab, run remaining strap between tab and head. Tuck strap back through head.

### Piggyback Plug Install

- ⚠ Electrical outlet must not be located in pump chamber.
  - ⚠ Electrical outlet voltage, piggyback plug voltage, and pump voltage must match.
1. Follow steps 1 through 4 of "Mounting the Switch."
  2. Insert switch's piggyback plug into outlet.
  3. Plug pump into piggyback plug.
  4. Check installation. Allow system to cycle to ensure proper operation.

### Direct Wire Install

1. Follow steps 1 through 4 of "Mounting the Switch."
2. Further wiring of switch should be done by qualified professionals only.
3. Check installation. Allow system to cycle to ensure proper operation.

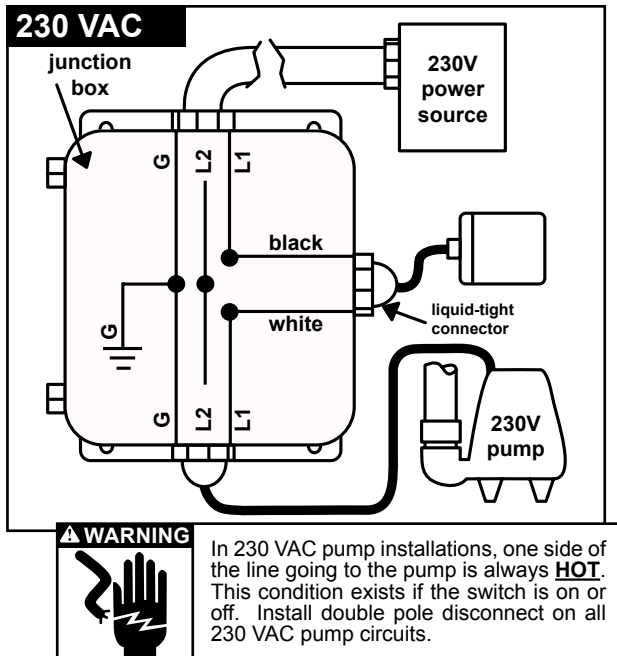

## REPLACING STATIONARY CUTTER PLATE AND ROTATING CUTTER

All repairs must be done at the factory or at an authorized Hydromatic service facility.

### ⚠ CAUTION!

**DISCONNECT ALL POWER AND CONTROL WIRES TO MOTOR AT CONTROL PANEL BEFORE STARTING DISASSEMBLY OPERATIONS. NEVER RELY ON OPENING CIRCUIT BREAKER ONLY.**

## DISASSEMBLY OF STATIONARY CUTTER PLATE AND ROTATING CUTTER

1. Remove retaining washer and screw from end of shaft. A screwdriver can be used to hold the shaft in place by wedging it between one of the four socket head cap screws and the rotating cutter while loosening the screw.
2. Using a rubber mallet, or soft metal hammer, bump rotating cutter in counterclockwise direction as thread is right-hand. Unthread rotating cutter from shaft. Be careful to not lose ring shims that space the rotating cutter from the stationary cutter plate.
3. Remove four socket head cap screws holding the stationary cutter plate to the volute. Remove stationary cutter from volute. If stationary cutter is stuck, the socket head cap screws can be threaded into tapped back-off holes in plate. Tighten screws to remove plate from volute.
4. Inspect rotating cutter and stationary cutter plate for wear and replace if worn.
5. Make sure pocket in volute is clean and reinstall stationary cutter plate using the four socket head cap screws. Apply blue Loctite® to the threads. Do not overtighten cap screws.
6. Replace ring shims (if removed from the shaft) and thread rotating cutter onto shaft. Make sure threads on shaft are clean and use Never-Seez® or other graphite compound on threads before replacing rotating cutter.
7. Using a rubber mallet, or soft metal hammer, bump rotating cutter in clockwise direction to make sure it is seated on the impeller.
8. To ensure proper operation of the cutter mechanism, the gap between the stationary cutter plate and rotating cutter must be no more than .008". To check the gap use a .008" feeler gauge. If the .008" feeler gauge does not fit between the surface of the stationary cutter and rotating cutter and the motor shaft turns freely, the gap is set correctly. If the .008" feeler gauge fits between the surfaces, shims must be removed to close the gap.

## SAFETY WARNINGS

**⚠ WARNING!** Risk of electrical shock. Pumps are supplied with a grounding conductor and grounding-type attachment plug on the power cord. To reduce the risk of electrical shock, be certain that it is connected only to properly grounded, grounding-type receptacle. **DO NOT** cut off ground pin or use an adapter fitting. **DO NOT** use an extension cord with this pump. When wiring this pump follow all local electrical, safety codes and ordinances as well as most recent National Electric Code (NEC-ANSI/NFPA).

The HVR200 Series grinder pumps have a GROUND WIRE that is connected to a screw in the metal motor housing. This wire goes to the receptacle or control box which must be connected to a good outside GROUND such as a metal water pipe or GROUND STAKE driven at least 8 feet into the ground.

### CALIFORNIA PROPOSITION 65 WARNING:

**⚠ WARNING** This product and related accessories contain chemicals known to the State of California to cause cancer, birth defects or other reproductive harm.

## DISMANTLING PUMP FOR REPLACEMENT PARTS

Before dismantling pump for replacement parts, clean pump thoroughly.

9. Replace retaining washer and screw in the end of the shaft. Be sure screw is tight. A screwdriver can be used to hold the shaft in place by wedging it between one of the four socket head cap screws and the rotating cutter while tightening the screw.
10. Be sure shaft turns freely after reassembly. Some drag will occur due to the seal, but there should be no binding or tight spots when turning the rotating cutter.
11. If rotating cutter rubs or drags on stationary cutter plate, recheck gap and re-shim rotating cutter.

## TO REPLACE CAPACITORS ONLY

1. Remove oil fill plug near the top of motor housing and pour oil out.
2. Loosen the cord nut on power cord until cord is loose enough to push cord down into motor housing.
3. Remove four bolts from motor housing and bump housing with a plastic hammer to loosen. Lay pump on its side.
4. Remove the housing carefully to be sure that enough cord is pushed into the housing so as not to create tension on cord.
5. Slide motor housing up far enough to expose the capacitors and to be able to lay the housing down.
6. Disconnect wiring from capacitor and loosen capacitor clamp and slide capacitor out. Replace with new capacitor, tighten clamp and reconnect.
7. Check all wiring connectors to be sure they are secure.
8. Be sure O-ring is in place.
9. Slide motor housing back onto pump while pulling the cord out slowly. Assemble motor housing with four bolts.
10. Reassemble cord nut. Be sure washers are seated and cord is pulled up against the washers. Tighten nut securely.
11. Put pump upright and refill motor with Hydromatic submersible pump oil. **DO NOT OVERFILL WITH OIL.** Replace oil plug. Retighten plug firmly, but do not overtighten.
12. Be sure pump turns freely before connecting power. Turn pump on side and turn impeller, using screwdriver in slotted shaft. Plug pump into receptacle to test operation. Pump must run quietly and free of vibration.

## WIRING DIAGRAM – MARATHON®

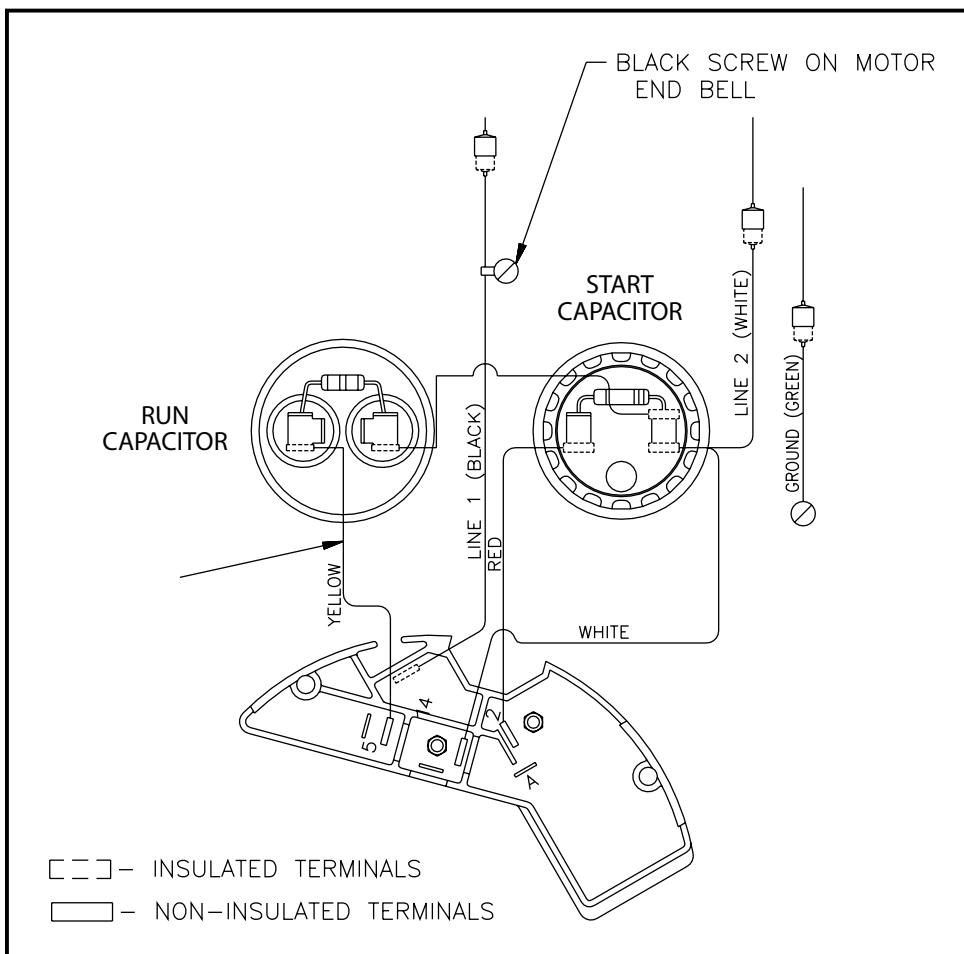

## TROUBLESHOOTING GUIDE

**Pump does not run or hum.**

See A, B, C, D, E or F.

**Pump runs but does not deliver water.**

See G, H, I, J, K or L.

**Pump runs and pumps out sump but does not stop.**

See M.

**Pump runs but delivers only small amount of water.**

See I, J, K, L or N.

**Fuse blows or circuit breaker trips when pump starts.**

See K, L, N, O or P.

**Motor runs for short time then stops. Then after short period starts again. Indicates tripping overload caused by symptom shown.**

See K, L, N or P.

**For any other symptoms contact a Hydromatic authorized service facility.**

- A.** Line circuit breaker may be off; or fuse, if used, may be blown or loose.
- B.** Water level in sump may be too low. Run in more water.
- C.** Pump cord plug may not be making contact in receptacle.
- D.** If pump is using the series cord plug, the two plugs may not be plugged tightly together.
- E.** Float may be stuck. Be sure float operates freely in basin. Check tether length of switch.
- F.** If all symptoms check OK, motor winding may be open; take to service center for repair.
- G.** Check valve may be installed backward. Arrow on valve points in direction of flow.
- H.** Discharge shut-off valve, if used, may be closed.
- I.** Pump may be air locked. Start and stop several times by plugging and unplugging cord. Check vent hole on pump case for plugging.
- J.** Pump head may be too high. Horizontal distance does not affect pumping, except loss due to friction.
- K.** Inlet holes in pump base may be clogged. Remove pump and clean out openings.
- L.** Impeller or volute openings may be plugged or partially plugged. Remove pump and clean. Check tether length of switch.
- M.** Float is stuck in up position. Be sure float operates freely in basin.
- N.** Pump impeller may be partially clogged causing motor to run slow, resulting in motor overload.
- O.** Fuse size or circuit breaker is too small. Must be 20 amps.
- P.** Defective motor stator. Return to Hydromatic service center.

## MOTOR END PARTS

### COMMON PARTS LIST For use with product built with Marathon® motor.

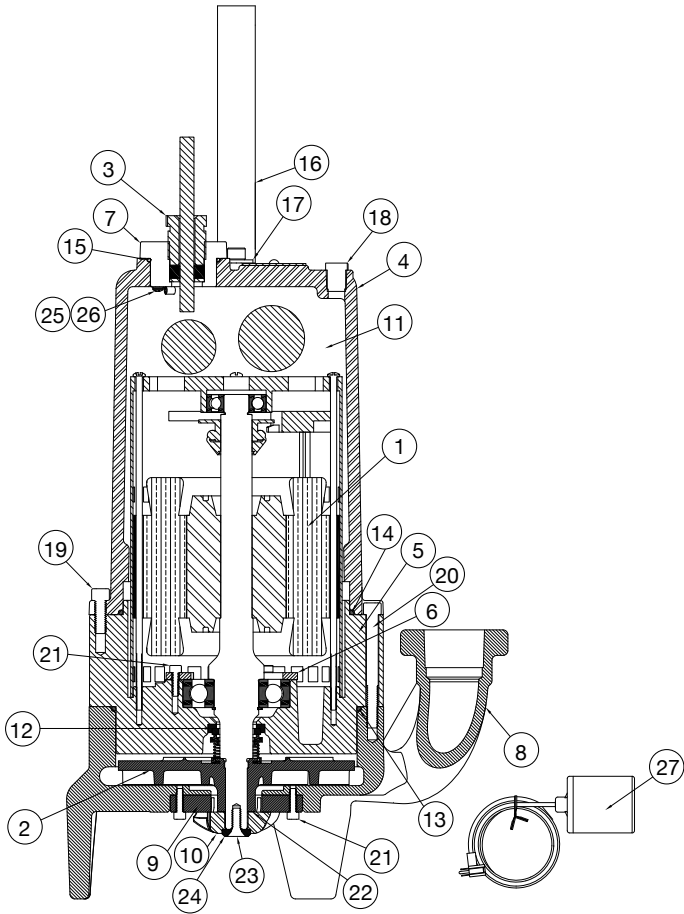

Item	Engineering No.	Description	Qty
1	28165B000	HVRS200A-21 Motor Assembly	1
		HVRS200M-21 Motor Assembly	1
2	28197B001	Impeller, 5.25" O.D.	1
3	25338B001	Power Cord, 14-3, 20'	1
4	28132B000	Motor Housing	1
5	28188D000	Seal/Bearing Housing	1
6	28198A000	Bearing Retainer, HVRS	1
7	28193B000	Cord Cap Plate	1
8	28133D000	Volute	1
9	28145B000	Stationary Cutter	1
10	28146B001	Rotating Cutter	1
11	132531001	Premium Oil	0.8 Gallons
12	21576A011	Seal, 7/8" Shaft	1
13	05876A120	O-ring, 1/8" X 6.25 I.D.	1
14	05876A125	O-ring, 1/8" X 5.859 I.D.	1
15	05876A244	O-ring, 3/32" X 1.737 I.D.	1
16	25371B010	Lifting Bail	1
17	05030A020	Washer, Flat, 5/16"	2
18	05022A088	Plug, 1/4" Pipe	1
19	001780081	Screw, Socket Head, 5/16" X .875"	8
20	001780101	Screw, Socket Head, 5/16" X 3.00"	4
21	048200061	Screw, Socket Head, 10-24 X .625"	7
22	006280571	Shim; 1.00 OD x .625 ID x .002	1
	006280591	Shim; 1.00 OD x .625 ID x .020	1
	006280601	Shim; 1.00 OD x .625 ID x .030	1
	006280581	Shim; 1.00 OD x .625 ID x .005	1
23	07597A018	Screw, Flat Head, 1/4" x .75"	1
24	21583A000	Washer, Retaining	1
25	000630021	Screw, 6-32 x .25"	1
26	009950011	Lockwasher, Star	1
27	145950201	Float Switch, Wide Angle, 20' (HVRS200A)	1

**THIS PAGE INTENTIONALLY LEFT BLANK**



# HYDROMATIC® HV200 SERIES LIMITED WARRANTY

Pentair Hydromatic® warrants its HV and HVR series grinders against defects in material and workmanship for a period of 24 months from the manufacturing date, or 36 months from the manufacturing date with completion of a start-up report within 30 days of installation. Product must be properly installed, serviced and operated in compliance with the manufacturer's instruction manuals.

During the warranty period and subject to the conditions set forth, Pentair Hydromatic, at its discretion, will repair or replace to the original user, the parts that prove defective in materials and workmanship. Pentair Hydromatic reserves the right to change or improve its products or any portions thereof without being obligated to provide such a change or improvement for prior sold and/or shipped units.

Start-up reports and electrical schematics may be required to support warranty claims. Submit at the time of start-up through the Pentair Hydromatic website: <http://forms.pentairliterature.com/startupform/startupform.asp?type=h>. All seal fail and heat sensing devices must be connected, functional and monitored or this warranty will be void. Pentair Hydromatic will cover only the lower seal and labor thereof for all dual seal pumps. Under no circumstance will Pentair Hydromatic be responsible for the cost of field labor, travel expenses, rented equipment, removal/reinstallation costs or freight expenses to and from the factory or an authorized Pentair Hydromatic service facility.

This limited warranty will not apply:

- a) To defects or malfunctions resulting from failure to properly install, operate or maintain the unit in accordance with the printed instructions provided;
- b) To failures resulting from abuse, accident or negligence;
- c) To failures resulting from excessive sand, lime, cement, gravel or other abrasive materials
- d) To failures caused by scale or corrosion build-up due to excessive hydrocarbons or chemical content
- e) To normal maintenance services and parts used in connection with such service;
- f) To units that are not installed in accordance with applicable local codes, ordinances and good trade practices;
- g) If the unit is moved from its original installation location;
- h) If unit is used for purposes other than for what it is designed and manufactured;
- i) To any unit that has been repaired or altered by anyone other than Pentair Hydromatic or an authorized Pentair Hydromatic service provider;
- j) To any unit that has been repaired using non factory specified/OEM parts.

Warranty Exclusions: PENTAIR HYDROMATIC MAKES NO EXPRESS OR IMPLIED WARRANTIES THAT EXTEND BEYOND THE DESCRIPTION ON THE FACE HEREOF. PENTAIR HYDROMATIC SPECIFICALLY DISCLAIMS THE IMPLIED WARRANTIES OF MERCHANTABILITY AND FITNESS FOR ANY PARTICULAR PURPOSE.

Liability Limitation: IN NO EVENT SHALL PENTAIR HYDROMATIC BE LIABLE OR RESPONSIBLE FOR CONSEQUENTIAL, INCIDENTAL OR SPECIAL DAMAGES RESULTING FROM OR RELATED IN ANY MANNER TO ANY PENTAIR HYDROMATIC PRODUCT OR PARTS THEREOF. PERSONAL INJURY AND/OR PROPERTY DAMAGE MAY RESULT FROM IMPROPER INSTALLATION. PENTAIR HYDROMATIC DISCLAIMS ALL LIABILITY, INCLUDING LIABILITY UNDER THIS WARRANTY, FOR IMPROPER INSTALLATION. PENTAIR HYDROMATIC RECOMMENDS INSTALLATION BY PROFESSIONALS.

Some states do not permit some or all of the above warranty limitations or the exclusion or limitation of incidental or consequential damages and therefore such limitations may not apply to you. no warranties or representations at any time made by any representatives of Pentair Hydromatic shall vary or expand the provision hereof.