

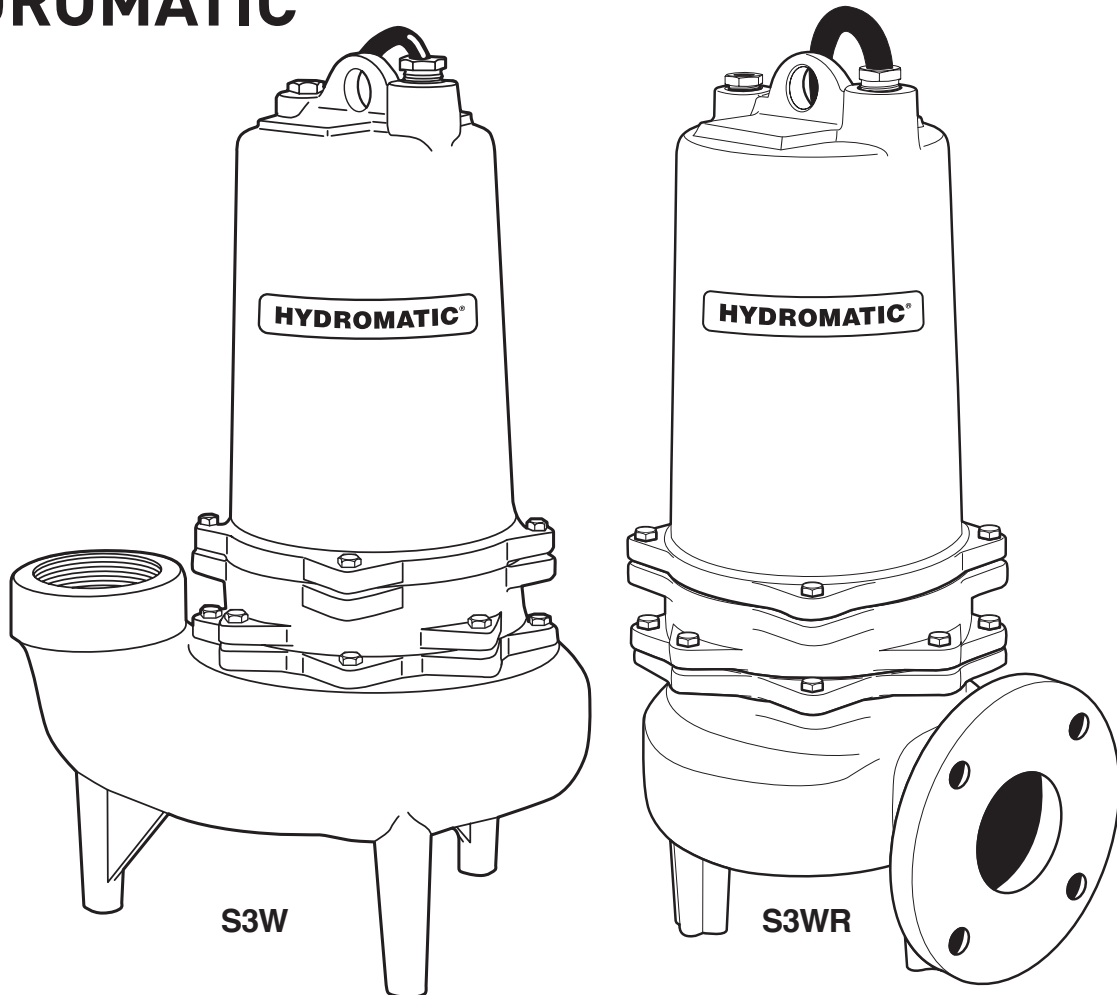

HYDROMATIC®



MODELS 1750 and 3450 RPM – S3W, S3WR SERIES **SUBMERSIBLE SEWAGE PUMPS**

INSTALLATION AND SERVICE MANUAL

Single and dual seal. Single and three phase power.



NOTE! To the installer: Please make sure you provide this manual to the owner of the equipment or to the responsible party who maintains the system.

General Information

Thank you for purchasing your Hydromatic® product. To help ensure years of trouble-free operation, please read the following manual carefully.

WARNING:

Only qualified personnel shall install or service this product.

Before Operation:

Read the following instructions carefully. Reasonable care and safe methods should be practiced. Check the local codes and requirements before installation.

Attention:

This manual contains important information for the safe use of this product. Read this manual completely before using this product and refer to it often for continued safe product use. **DO NOT THROW AWAY THIS MANUAL.** Keep it in a safe place so that you may refer to it often.

WARNING: Before handling electrical equipment, always disconnect the power first. Do not smoke or use sparkable electrical devices or flames in a septic (gaseous) or possible septic sump.

Safety Warnings

Failure to heed these warnings and follow the instructions in this manual may result in **severe bodily injury or death**, or **substantial property damage**.

DO NOT wear loose clothing that can become entangled in the impeller or other moving parts.

This pump is designed to handle materials that could cause illness or disease through direct exposure. Wear adequate protective clothing when working on the pump or piping.

NEVER operate a pump with a power cord that has frayed or brittle insulation.

NEVER let cords or plug lie in water.

NEVER handle connected power cords with wet hands.

WARNING: RISK OF ELECTRICAL SHOCK!

Single phase pumps are supplied with a grounding conductor and grounding-type attachment plug on the power cord. To reduce risk of electrical shock, be certain that it is connected only to a properly grounded, grounding-type receptacle. **DO NOT** cut off ground pin or use an adapter fitting. **DO NOT** use an extension cord with this pump.

Follow all local electrical and safety codes and ordinances as well as the most recent National Electric Code (NEC-ANSI/NFPA 70).

All pumps have a **GROUND WIRE** that is connected to a screw in the metal motor housing. This wire goes to the receptacle or control box which must be connected to a good outside **GROUND** such as a metal water pipe or **GROUND STAKE** driven at least 8 feet into the ground.

Pumps

1. Pumps build up heat and pressure during operation. Allow time for pump to cool before handling or servicing.
2. Only qualified personnel should install, operate or repair pump.
3. Keep clear of suction and discharge openings. **DO NOT** insert flingers in pump with power connected.
4. This pump **MUST NOT** be used to pump flammable, combustible or hazardous liquids. Make sure lifting handles are securely fastened each time before lifting.
5. **DO NOT** lift pump by power cord.
6. **DO NOT** exceed manufacturer's recommendation for max. performance, as this could cause the motor to overheat.
7. **ALWAYS** secure the pump in its operating position so it cannot tip over, fall or slide.
8. Keep hands and feet away from impeller when power is connected.
9. **DO NOT** use in swimming pools, decorative fountains or any installation where human contact with pumped fluid is common.
10. Do not operate pump without safety devices in place.

CALIFORNIA PROPOSITION 65 WARNING:

▲ WARNING This product and related accessories contain chemicals known to the State of California to cause cancer, birth defects or other reproductive harm.

IMPORTANT! Hydromatic is not responsible for losses, injury or death resulting from a

failure to observe these safety precautions, misuse or abuse of pumps or equipment.

General Description and Application

The S3W and S3WR series sewage pumps are available in both a single seal and dual seal with leak detector and in 1750 RPM and 3450 RPM models. They are designed for raw sewage applications. These units can also be used for sump and general dewatering applications where larger solids capabilities are required.

These pumps are available in single and three phase. All three phase units, all dual seal units and all duplex installations must be used with a control box.

Air Venting

Upon initial filling of wet well with water, air may be trapped in the pump volute. To vent off this air a 5/32" diameter hole is located in volute. **BE SURE THIS VENT HOLE IS CLEAN AFTER ANY SERVICE WORK ON PUMP.**

Level Controls

All pumps must use sealed level control switches for automatic operation.

Simplex single phase pumps can be made automatic by attaching MFS controls to the pump or

discharge pipe. These switches have a fixed draw-off level of 8 to 10 inches and can be used up to 1 HP. Simplex and higher horsepower systems may also use on/off pilot control switches (SMNO) with control box and magnetic starter. The ALC and AWS-1 controls can be used for simplex single phase pumps with ratings up to 2 HP. All duplex systems must use pilot control switches (SNMO) with control box and magnetic starters.

Plug-in cords can be used on all the single phase pumps with a single seal (does not have seal leak detector). This cord has a GROUND pin that plugs into a grounded receptacle. The grounded receptacle cannot be used in the wet sumps or basin due to DANGER of current leakage. Sealed junction boxes must be used in wet sumps or basins to make connections to motor cord. The AWS-1 control also acts as a sealed junction box for connecting power cord to pump cord.

Dual Seal Pumps

Dual seal units are all made with a seal leak detector. The leak detector in the oil seal chamber detects a water leakage into the chamber and turns on a red signal light in the control panel. Control panels must be used for pumps having the seal leak detectors, and seal leak must be wired.

Pump Motor Type

Motors are ¾ frame 1, 1½, 2 and 3 HP single or three phase, 60 hertz, 1750 & 3450 RPM with

class B insulation. All single phase motors are permanent split-capacitor (PSC) type with built-in winding overload protection and do not require a start switch or start relay. The three phase pump motors require a magnetic starter with 3 leg overload protection. All motors have upper and lower ball bearings and all are oil-cooled and lubricated.

Pump Installation

WARNING: Basin or tank must be vented in accordance with local plumbing codes. These pumps are not designed for and **CANNOT** be installed in locations classified as hazardous in accordance with the National Electric Code ANSI/NFPA 70.

CAUTION: Never enter pump chamber after sewage or effluent has been in basin. Sewage water can give off methane, hydrogen sulfide and other gases that are highly poisonous. For this reason, Hydromatic recommends installing the S3W and S3WR series sewage pumps with a quick removal system. The quick removal system may be a union or Cam-lok® coupling if the pipe or discharge hose is within reach from the surface, or a rail system type quick disconnect on deeper installations.

The dosing tank or pumping chamber must be constructed of corrosion resistant materials and must be capable of withstanding all anticipated internal and external loads. It also must not allow infiltration or exfiltration. The tank must also have provisions for anti-buoyancy. Access holes or covers must be of adequate size and be

accessible from the surface to allow installation and maintenance of the system. **ACCESS COVERS MUST BE LOCKABLE OR HEAVY ENOUGH TO PREVENT EASY ACCESS TO UNAUTHORIZED PERSONNEL.** The pumping chamber holding capacity should be selected to allow for emergency conditions.

The discharge pipe must be the same size as the pump discharge (3 inches) or larger. In order to ensure sufficient fluid velocity to

prevent any residual solids from collecting in the discharge pipe, it is recommended that a minimum flow of 2 feet per second be maintained (46 gpm through 3" pipe). It is recommended that a PVC or equal pipe is used for corrosion resistance. A full flow (ball or gate) shut-off valve must be installed to prevent back flow of sewage if the pump must be removed for service. A **CHECK VALVE MUST BE INSTALLED ON PRESSURE SEWER SYSTEMS** and on other

systems where conditions allow to prevent back flow and to reduce wear on the pump system.

A high water alarm must be installed on a separate circuit from the pump circuit. The alarm should have the ability to be tested for proper operation.

Special Instructions for Three Phase Pumps

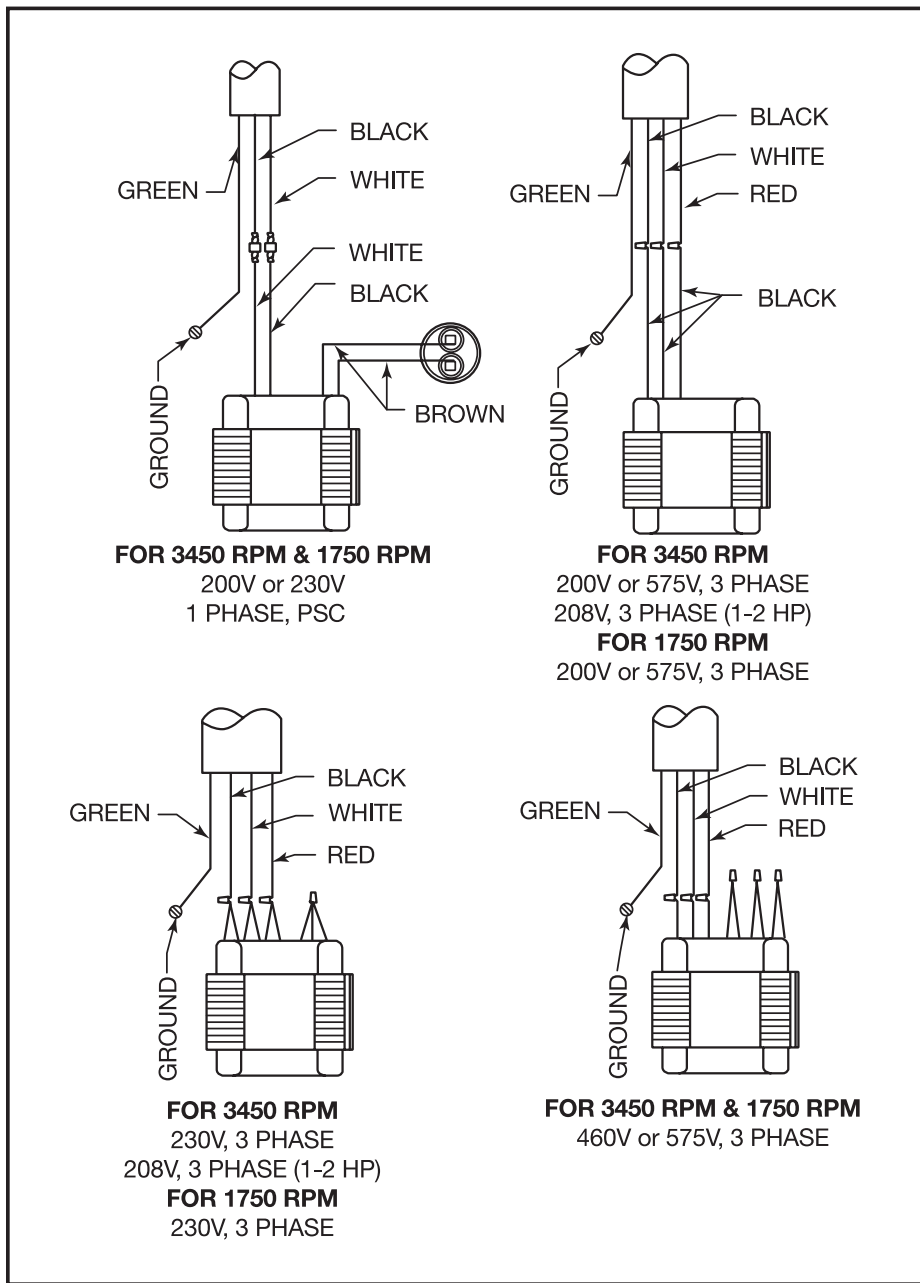

1. Hydromatic recommends three phase pumps to be installed by qualified personnel. **CAUTION: RISK OF ELECTRICAL SHOCK!** Do not remove cord and strain relief. **DO NOT** connect conduit to pump.
2. Three phase pumps are always installed with control boxes having magnetic starters with 3-leg overload protections. **DO NOT TRY TO RUN THREE PHASE PUMPS DIRECTLY ACROSS THE LINE.**
3. **To Connect Pump:** Run wire from pump to bottom of control box or appropriate junction box suitable for enclosing splice connections. A hole must be cut into the control box for the wires. With power on control box OFF, connect green (ground) line to ground lug. Connect black (power) wires to power lead terminals. Note: For a typical CE style control box, these terminals are M1, M2 and M3. Make sure that all wires are inside control box and not in a position to be pinched or shorted when door is closed.

4. **Before installing pumps check rotation of impeller** to make sure pump is connected correctly to magnetic starter. All pump impellers either single or three phase must turn counterclockwise when looking into pump inlet. To check for proper rotation, lay pump on side so impeller is visible. Turn on power and start pump using Hand position of H-O-A switch. Turn on and off fast so that coast of impeller can be seen. **NEVER PUT HANDS OR FINGERS ON THE IMPELLER WHEN POWER IS CONNECTED.** Interchange any two line leads at magnetic starter to change if rotation is incorrect.

Pump Troubleshooting

Below is a list of troubles and their probable causes:

Pump does not run or start when water is up in tank.

1. Check for blown fuse or tripped circuit breaker.
2. Check for defective level switch.
3. Where control panel is used be sure H-O-A switch is in the Auto position. If it does not run, turn switch to Hand position and if pump runs then the trouble is in the automatic electrical system. Have an electrician make electrical checks.
4. Check for burned-out motor. Occasionally lightning can damage a motor even with lightning protection.
5. Where plug-in cords are used be sure contact blades are

clean and make good contact. **DO NOT USE PLUG-IN CORDS INSIDE A SUMP OR WET WELL.**

6. Level control ball or weight may be stuck on the side of basin. Be sure it floats freely.

Pump runs but does not deliver flow.

1. Check air lock. Start and stop pump several times; if this does not help it may be necessary to loosen a union in the discharge line to relieve air lock.
2. Check valve may be installed backward. Check flow arrow on valve body. Check shut-off valve. It may be closed.
3. Check vertical elevation. It may be higher than pump can develop (see pump curve).
4. Pump inlet may be plugged. Remove pump to check.

Single Seal Repair Parts List

S3W/S3WR Series – 3450 & 1750 RPM

Ref. No.	Part No.	Part Description	Qty.
1	25341A002	Nut, Cord Plug, Solid	1
2	05030A234	Washer, 1/32" Thk.	1
3	05014A193	Gasket, Rubber	1
4	05030A235	Washer, 3/32" Thk.	1
5	See Chart	Cord, Power	1
6	25327D000	Housing, Motor	1
7	05022A092	Plug, 1/4" Pipe	1
8	See Chart	Capacitor (1 ph Only)	1
9	See Chart	Clip, Capacitor (1 ph Only)	1
10	19331A005	Washer, Bearing	1
11	08565A013	Bearing, Ball, Upper	1

Ref. No.	Part No.	Part Description	Qty.
12	See Chart	Stator, Rotor Shaft with Shell	1
13	08565A022	Bearing, Ball, Lower 3450	1
	08565A018	Bearing, Ball, Lower 1750	1
14	25370A000	Seal, Shaft 3450	1
	21576A010	Seal, Shaft 1750	1
15	19100A012	Screw, Cap, 5/15 x 1-1/4	4
16	25367D000	Plate, Brg & Seal 3450	1
	26430D000	Plate, Brg & Seal 1750	1
17	05014A181	Gasket, Tetraseal, 7 x 6-3/4 x 1/8	1
18	19100A012	Screw, Cap, 5/16 x 1-1/4	4
19	09822A032	Screw, St, #10 x 3/8	2

Item Number			5	8	9	12	
HP	Volts	Phase	Power Cord No. Plug	Capacitor	Capacitor Clip	Stator Rotor & Shaft Ass'y 3450 RPM	Stator Rotor & Shaft Ass'y 1750 RPM
1	208	1	25338B002	23838A000	2033A004	25484D104	
1	230	1	25338B002	23838A000	2033A004	25484D105	
1	208	3	25338B003			25484D106	
1	230	3	25338B003			25484D106	
1	460	3	25338B003			25484D106	
1	575	3	25338B003			25484D107	
1-1/2	208	1	25338B002	23838A000	2033A004	25484D104	
1-1/2	230	1	25338B002	23838A000	2033A004	25484D105	25484D114
1-1/2	208	3	25338B003			25484D106	25484D116
1-1/2	230	3	25338B003			25484D106	25484D116
1-1/2	460	3	25338B003			25484D106	25484D116
1-1/2	575	3	25338B003			25484D107	25484D117
2	208	1	25338B009	23839A000	20333A006	25484D108	
2	230	1	25338B009	26520A000	20333A006	25484D109	25484D114
2	208	3	25338B008			25484D110	25484D116
2	230	3	25338B008			25484D111	25484D116
2	460	3	25338B003			25484D111	25484D116
2	575	3	25338B003			25484D112	25484D117
3	208	1	25338B009	23839A000	20333A006	25484D108	
3	230	1	25338B009	26520A000	20333A006	25484D109	25484D114
3	208	3	25338B008			25484D110	25484D116
3	230	3	25338B008			25484D111	25484D116
3	460	3	25338B003			25484D111	25484D116
3	575	3	25338B003			25484D112	25484D117

S3W/S3WR Single Seal Pumps – Motor End Parts

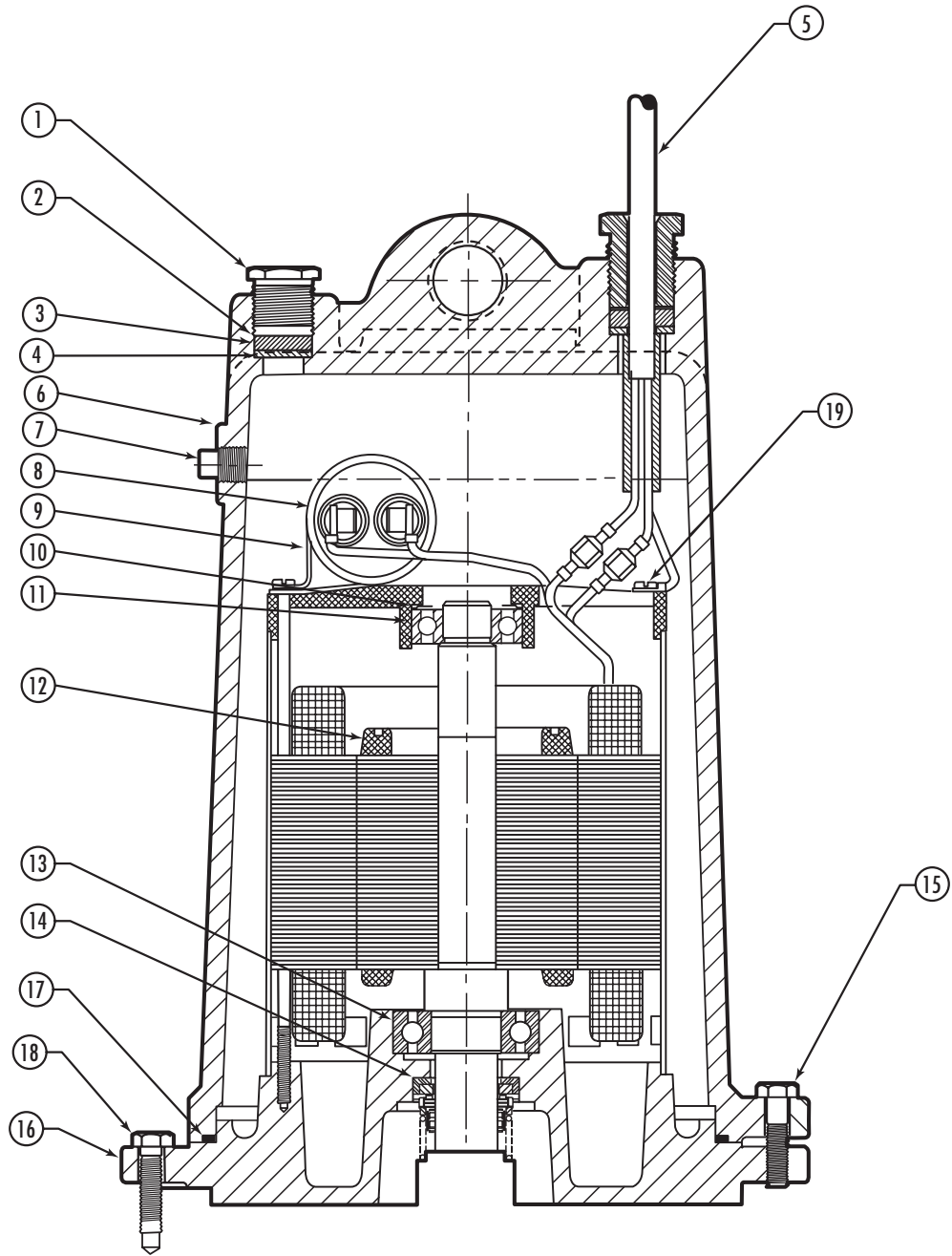

Dual Seal Repair Parts List

S3W/S3WR Series – 3450 & 1750 RPM

Ref. No.	Part No.	Part Description	Qty.
1	25339B000	Cord, Sensor	1
2	See Chart	Cord, Power	1
3	25327D000	Housing, Motor	1
4	05022A092	Plug, 1/4" Pipe	1
5	See Chart	Capacitor (1 ph Only)	1
6	See Chart	Clip, Capacitor (1 ph Only)	1
7	19331A005	Washer, Bearing	1
8	08565A013	Bearing, Ball, Upper	1
9	See Chart	Stator, Rotor Shaft with Shell	1
10	08565A022	Bearing, Ball, Lower 3450	1
	08565A018	Bearing, Ball, Lower 1750	1
11	25370A000	Seal, Shaft 3450	2
	21576A010	Seal, Shaft 1750	2

Ref. No.	Part No.	Part Description	Qty.
12	19100A012	Screw, Cap, 5/16 x 1-1/4	4
13	25369D000	Housing, Seal 3450	1
	25369D001	Housing, Seal 1750	1
14	05014A181	Gasket, Tetraseal, 7 x 6-3/4 x 1/8	2
15	19100A012	Screw, Cap, 5/16 x 1-1/4	4
16	25368D000	Lower, Seal Plate 3450	1
	26476D000	Lower, Seal Plate 1750	1
17	09822A032	Screw, St, #10 x 3/8	2
18	21792A004	Wire Electrode	2
19	05434A025	Screw Machine #6 x 1/4	2
20	25343A000	Probe, Seal Leak	2

Item Number			2	5	6	9	
HP	Volts	Phase	Power Cord No. Plug	Capacitor	Capacitor Clip	Stator Rotor & Shaft Ass'y 3450 RPM	Stator Rotor & Shaft Ass'y 1750 RPM
1	208	1	25338B002	23838A000	2033A004	25484D204	
1	230	1	25338B002	23838A000	2033A004	25484D205	
1	208	3	25338B003			25484D206	
1	230	3	25338B003			25484D206	
1	460	3	25338B003			25484D206	
1	575	3	25338B003			25484D207	
1-1/2	208	1	25338B002	23838A000	2033A004	25484D204	
1-1/2	230	1	25338B002	23838A000	2033A004	25484D205	25484D214
1-1/2	208	3	25338B003			25484D206	25484D216
1-1/2	230	3	25338B003			25484D206	25484D216
1-1/2	460	3	25338B003			25484D206	25484D216
1-1/2	575	3	25338B003			25484D207	25484D217
2	208	1	25338B009	23839A000	20333A006	25484D208	
2	230	1	25338B009	26520A000	20333A006	25484D209	25484D214
2	208	3	25338B008			25484D210	25484D216
2	230	3	25338B008			25484D211	25484D216
2	460	3	25338B003			25484D211	25484D216
2	575	3	25338B003			25484D212	25484D217
3	208	1	25338B009	23839A000	20333A006	25484D208	
3	230	1	25338B009	26520A000	20333A006	25484D209	25484D214
3	208	3	25338B008			25484D210	25484D216
3	230	3	25338B008			25484D211	25484D216
3	460	3	25338B003			25484D211	25484D216
3	575	3	25338B003			25484D212	25484D217

S3W/S3WR Dual Seal Pumps – Motor End Parts

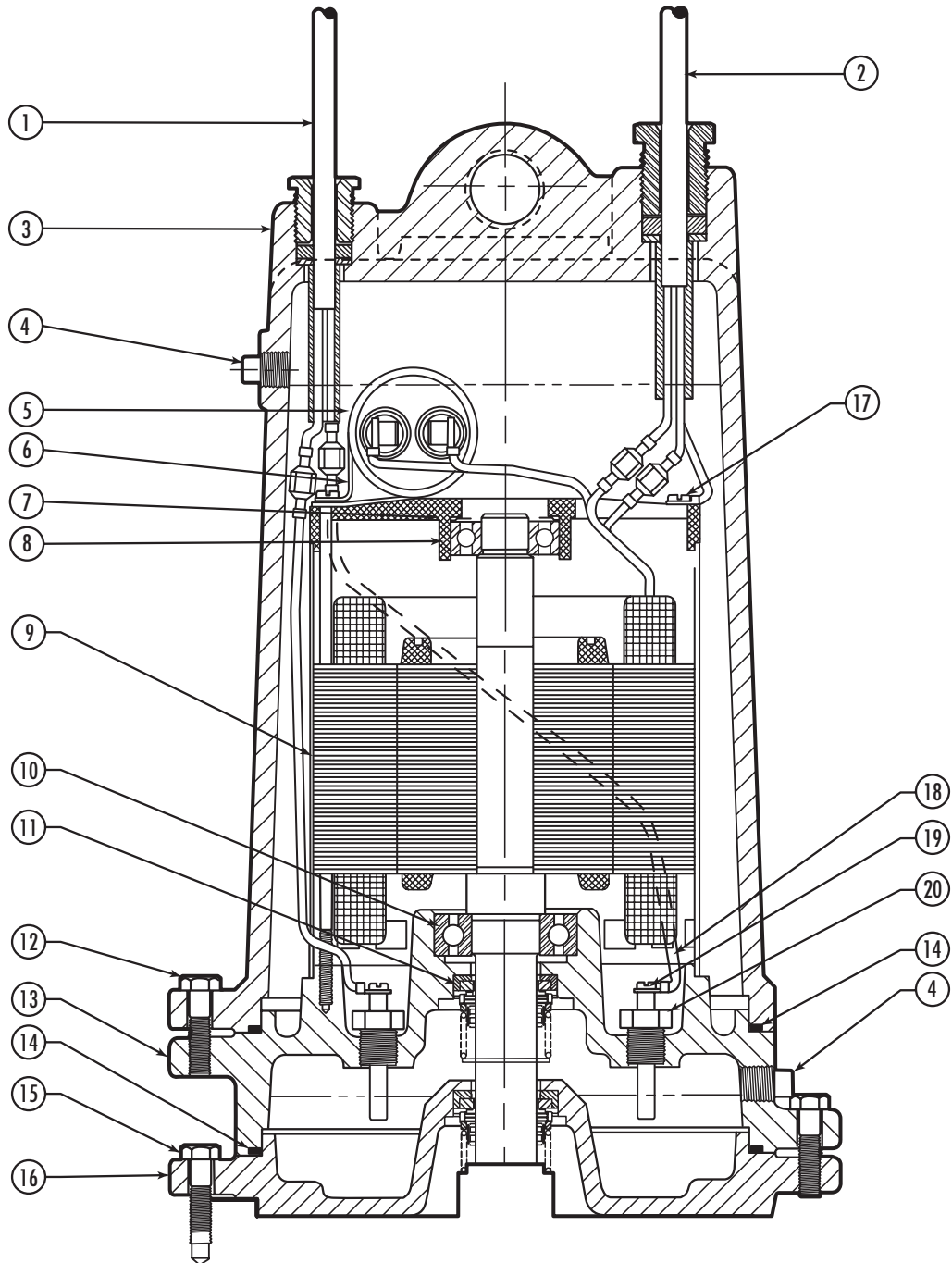

Wet End Repair Parts List

S3W/S3WR Series – 3450 & 1750 RPM

Ref. No.	Part No.	Part Description	Qty.
21	See Chart	Impeller, S3W 1750, 3450	1
21	See Chart	Impeller, S3WR 1750, 3450	1
22	05030A262	Washer, Impeller Retainer, 3450	1
22	22585A000	Washer, Impeller Retainer, 1750	1
23	06106A042	Screw, Machine #10 x 3/8, 3450	1
23	07597A036	Screw, Machine 5/16 x 1, 1750	1

Ref. No.	Part No.	Part Description	Qty.
24	22835A009	Cup, U, Huva	1
25	26437D000	Case, Volute, S3W 1750	1
25	26423D000	Case, Volute, S3W 3450	1
25	27701D000	Case, Volute, S3WR 3450	1
25	27703D000	Case, Volute, S3WR 1750	1

Item Number			21			
HP	Volts	Phase	S3W Impeller 2 Pole	S3W Impeller 4 Pole	S3WR Impeller 2 Pole	S3WR Impeller 4 Pole
1	208	1	26029B012			
1	230	1	26029B012			
1	208	3	26029B012			
1	230	3	26029B012			
1	460	3	26029B012			
1	575	3	26029B012			
1-1/2	208	1	26029B011	26438C523	27702B002	27704B002
1-1/2	230	1	26029B011	26438C523	27702B002	27704B002
1-1/2	208	3	26029B011	26438C523	27702B002	27704B002
1-1/2	230	3	26029B011	26438C523	27702B002	27704B002
1-1/2	460	3	26029B011	26438C523	27702B002	27704B002
1-1/2	575	3	26029B011	26438C523	27702B002	27704B002
2	208	1	26029B000	26438C526	27702B001	27704B001
2	230	1	26029B000	26438C526	27702B001	27704B001
2	208	3	26029B000	26438C526	27702B001	27704B001
2	230	3	26029B000	26438C526	27702B001	27704B001
2	460	3	26029B000	26438C526	27702B001	27704B001
2	575	3	26029B000	26438C526	27702B001	27704B001
3	208	1	26029B004	26438C531	27702B000	27704B000
3	230	1	26029B004	26438C531	27702B000	27704B000
3	208	3	26029B004	26438C531	27702B000	27704B000
3	230	3	26029B004	26438C531	27702B000	27704B000
3	460	3	26029B004	26438C531	27702B000	27704B000
3	575	3	26029B004	26438C531	27702B000	27704B000

S3W/S3WR Wet End Repair Parts

S3W - 1750

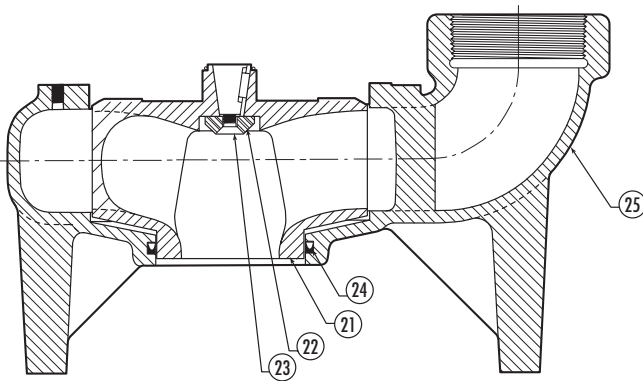

S3W - 3450

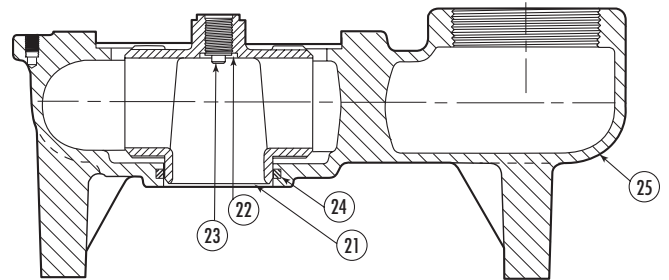

S3WR - 1750

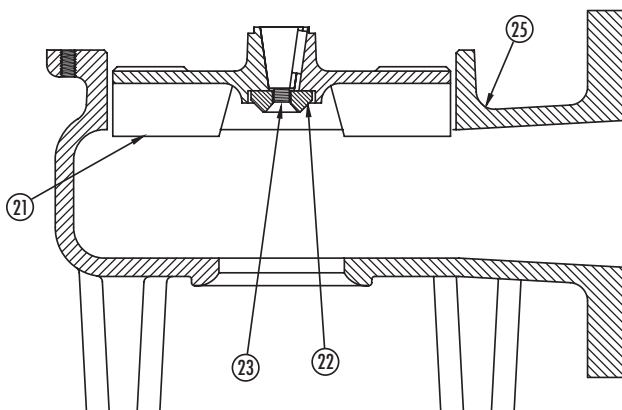

S3WR - 3450

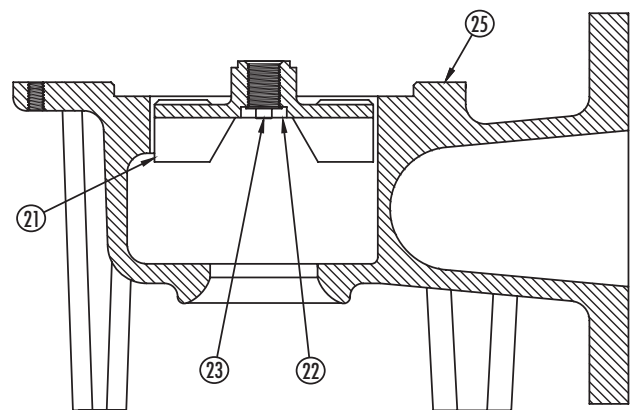

STANDARD LIMITED WARRANTY

HYDROMATIC® warrants its products against defects in material and workmanship for a period of 12 months from the date of shipment from Hydromatic or 18 months from the manufacturing date, whichever occurs first - provided that such products are used compliance with the requirements of the Hydromatic catalog and technical manuals for use in pumping raw sewage, municipal wastewater or similar, abrasive free non-corrosive liquids.

During the warranty period and subject to the conditions set forth, Hydromatic, at its discretion, will repair or replace to the original user, the parts which prove defective in materials and workmanship. Hydromatic reserves the right to change or improve its products or any portions thereof without being obligated to provide such a change or improvement for prior sold and/or shipped units.

Start-up reports and electrical schematics may be required to support warranty claims. Submit at the time of start up through the Hydromatic website: <http://forms.pentairliterature.com/startupform/startupform.asp?type=h>. Warranty is effective only if Hydromatic authorized control panels are used. All seal fail and heat sensing devices must be hooked up, functional and monitored or this warranty will be void. Hydromatic will only cover the lower seal and labor thereof for all dual seal pumps. Under no circumstance will Hydromatic be responsible for the cost of field labor, travel expenses, rented equipment, removal/reinstallation costs or freight expenses to and from the factory or an authorized Hydromatic service facility.

This limited warranty will not apply: (a) to defects or malfunctions resulting from failure to properly install, operate or maintain the unit in accordance with the printed instructions provided; (b) to failures resulting from abuse, accident or negligence; (c) to normal maintenance services and parts used in connection with such service; (d) to units which are not installed in accordance with applicable local codes, ordinances and good trade practices; (e) if the unit is moved from its original installation location; (f) if unit is used for purposes other than for what it is designed and manufactured; (g) to any unit which has been repaired or altered by anyone other than Hydromatic or an authorized Hydromatic service provider; (h) to any unit which has been repaired using non factory specified/OEM parts.

Warranty Exclusions: HYDROMATIC MAKES NO EXPRESS OR IMPLIED WARRANTIES WHICH EXTEND BEYOND THE DESCRIPTION ON THE FACE HEREOF. HYDROMATIC SPECIFICALLY DISCLAIMS THE IMPLIED WARRANTIES OF MERCHANTABILITY AND FITNESS FOR ANY PARTICULAR PURPOSE.

Liability Limitation: IN NO EVENT SHALL HYDROMATIC BE LIABLE OR RESPONSIBLE FOR CONSEQUENTIAL, INCIDENTAL OR SPECIAL DAMAGES RESULTING FROM OR RELATED IN ANY MANNER TO ANY HYDROMATIC PRODUCT OR PARTS THEREOF. PERSONAL INJURY AND/OR PROPERTY DAMAGE MAY RESULT FROM IMPROPER INSTALLATION. HYDROMATIC DISCLAIMS ALL LIABILITY, INCLUDING LIABILITY UNDER THIS WARRANTY, FOR IMPROPER INSTALLATION. HYDROMATIC RECOMMENDS INSTALLATION BY PROFESSIONALS.

Some states do not permit some or all of the above warranty limitations or the exclusion or limitation of incidental or consequential damages and therefore such limitations may not apply to you. No warranties or representations at any time made by any representatives of Hydromatic shall vary or expand the provision hereof.



USA

740 East 9th Street, Ashland, Ohio 44805
Tel: 419-289-3042 Fax: 419-281-4087

www.hydraulic.com

- Your Authorized Local Distributor -

CANADA

269 Trillium Drive, Kitchener, Ontario, Canada N2G 4W5
Tel: 519-896-2163 Fax: 519-896-6337