

The curve reflects maximum performance characteristics without exceeding full load (Nameplate) horsepower. Operation is recommended near the Best Efficiency Point. Operating at the outer limits of the curve is not recommended. Performance curves are based on actual tests with clear water at 70° F. and 1280 feet site elevation.

Conditions of Service:  
 GPM: \_\_\_\_\_ TDH: \_\_\_\_\_

**V7D Series Performance Data**  
 Discharge: 4"      Solids: 4"

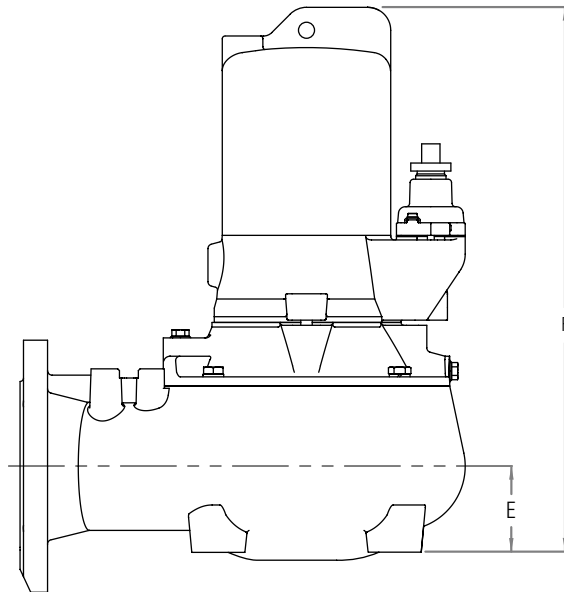
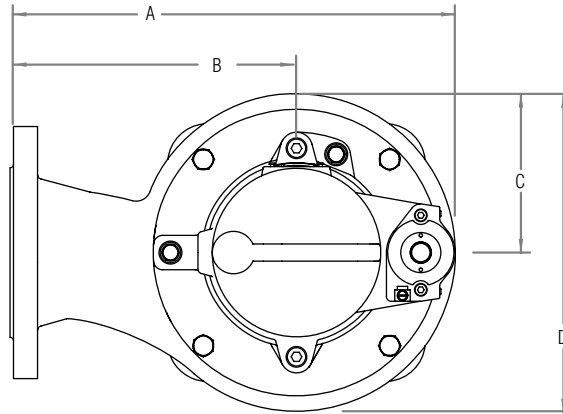

Model	A		B		C		D		E		F		Weight	
	mm	in	mm	in	mm	in	mm	in	mm	in	mm	in	kg	lbs
V7D-43	486.5	19.15	299	11.77	187.5	7.38	375	14.76	97	3.82	638	25.12	117	258

Component dimensions may vary  $\pm 1/8$  inch. Dimensional data not for construction purpose unless certified. Dimensions and weights are approximate. We reserve the right to make revisions to our product (s) and the product (s) specifications without notice.

**V7D Series Dimensional Data**  
 Discharge: 4" Solids: 4"

## MODEL: V7D Series Solids Handling Pumps

	Units	V7D-43
Motor type		D 112-4/140 O
Frequency	Hz	60
Voltage / tolerance	V	3ø ~460V ± 10%
F.L.A.	A	12.3
R.P.M.	1/min	1670
cos phi		0.81
cos phi-start		0.7
Maximum ON/OFF cycles per hour	1/h	60
Start Amp. (at H=3 ft and rated voltage)		68
ISO-class		F
Enclosure		IP 68
Winding protection / control unit required		150° C Therm. / Yes
Ext. motor protection required		Yes
Winding resistance	Ohm	3.2
Service Factor		1.04
Standard Cable		25 ft SOOW 12/6 AWG 12

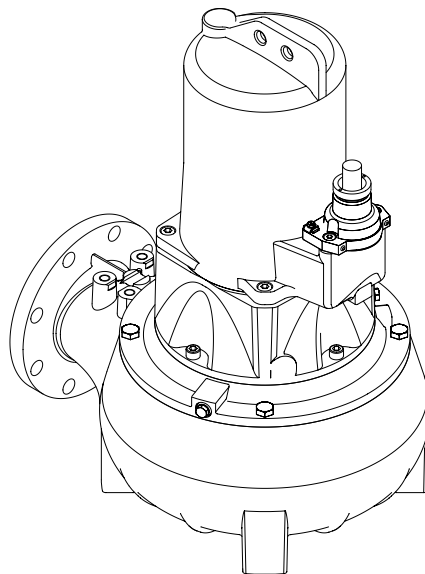

### V7D Series Electrical Data

Discharge: 4"      Solids: 4"

## MODEL: V7D Series Solids Handling Pumps

	Units	V7D-43
Max. head	ft	52
Max. flow rate	GPM	748
Torque LRT/FLT/POT	lb/ft	54.6 / 31.7 / 75.2
Bearing n.d.e.		6205 double shielded ball
Bearing d.e.		3309 double row angular contact ball
O-rings		NBR 70 DIN 3771
Shaft seal motor side	mm	2 - 40 x 30 KK/Cr mech. seal
Shaft seal medium side	mm	35 x 36 SiC mech. seal
Volute type / material		Ring CW / GG-25 cast iron
Discharge connection		DIN 100 (4") ANSI #150
Inlet diameter	in	Ø 3.94
Impeller type / material		vortex / GGG-60 cast iron
Impeller diameter	in	Ø 7.874
Vane qty / height	in	6 / 1.575
Free passage	in	3.937
Total inertia	lb ft <sup>2</sup>	2.017
Weight with cable	lbs	258
Oil chamber qty / oil grade	in <sup>3</sup>	103.7 / SAE 5W-15W (ISO 22-44) Mineral oil
Materials of Construction		
Coating		2K Epoxy, 80 µm, black
Motor casing		GG-20 cast iron
Bearing chamber		
Pump shaft		C 45 K covered

### V7D Series Technical Data

Discharge: 4"      Solids: 4"



## MODEL:V7D Series Solids Handling Pumps

### 1.01 General

Contractor shall furnish all labor, materials, equipment and incidentals required to provide (Qty.) submersible centrifugal solids handling sewage pump(s) as specified herein. The pump models covered in this specification are the V7D Series. The pump furnished for this application shall be MODEL \_\_\_\_\_ as manufactured by Jung Pumpen of Delavan, Wisconsin (800-642-5930).

### 2.01 Design Conditions

Each pump shall be rated \_\_\_\_\_ H.P., \_\_\_\_\_ volts, \_\_\_\_\_ phase, \_\_\_\_\_ hertz and operate at \_\_\_\_\_ RPM. The pump shall deliver \_\_\_\_\_ U.S. GPM/LPS at \_\_\_\_\_ feet/meters TDH., and handle a \_\_\_\_\_ inch solid. The reserve service factor shall be a minimum of \_\_\_\_\_. The specification submitted for approval shall state, in addition to flow and head capacity performance, solid handling capability, amp rating, and design impeller diameter.

### 3.01 Construction

Each pump shall be of the sealed submersible type, incorporating features normally found in pumps furnished for the heavy duty industrial or municipal markets.

These features include:

- 3.02 The castings shall be constructed of epoxy coated cast iron.
- 3.03 The seal housing is cast iron.
- 3.04 The pump inlet shall be open and clear, without screening to provide access for sewage and solids.
- 3.05 All external mating parts shall be machined and Buna N, O-Ring sealed.
- 3.06 All fasteners exposed to the pumped liquid shall be 300 series stainless steel.  
As an optional feature include \_\_\_\_\_ seal leak probes in the seal chamber.

### 4.01 Electrical Power Cord

All power cords shall be SO-type water resistant UL or CSA approved, with double insulation, and sized as a function of Full Amp. draw.

### 5.01 Motor

The stator, rotor and bearings shall be mounted in a sealed submersible type housing. Three phase motors shall be Polyphase. Full Load and Locked Rotor Amps. as well as Start and Run winding resistance shall be tabulated for each pump.

### 6.01 Bearings, Shaft And Mechanical Seal

An upper radial ball bearing and a lower double row angular contact ball bearing shall be required. The motor shaft shall be stainless steel and sealed from the pumped liquid with a silicone carbide mechanical seal and two lip seals.

### 7.01 Impeller

The impeller shall be a high capacity, six vane, non clog design with pump out vanes on the back side. These vanes wash out grit and stringy material that will damage the shaft and mechanical seal.

#### V7D Series Specification Data

Discharge: 4"                      Solids: 4"

Wholesale Products Page: **JP10084SSD-5**

Section: **Specification Data**

Dated: **January, 2011**



### **8.01 Painting**

All cast iron parts shall be painted before assembly with a black high solids epoxy mastic and applied in one coat with a minimum thickness of 8 mils.

### **9.01 Serviceability**

Components required for the repair of the pump shall be readily available within 24 hours. Components such as mechanical seals and bearings shall not be of a proprietary design and be available from local industrial supply houses. Special tools shall not be required to service the pump. A network of service stations shall be available nationwide in those cases where service requirements are beyond the scope of in-house service mechanics.

### **10.01 Support**

Optional support legs are available, enabling pump to be a freestanding unit. The legs will be high enough to allow passage of solid matter below the housing.

### **11.01 Testing**

All pumps shall be individually tested to include the following:

- 11.02 The pump and power cord shall be visually inspected for imperfections, cuts or nicks.
- 11.03 The pump shall have a ground continuity check and the motor chamber shall be Hi-potted to test for moisture content and/or insulation defects.
- 11.04 The motor and volute housing shall be pressurized and a 10 second air leak decay test run.
- 11.05 Oil is added by the tester and the pump is run. Voltage and current are monitored visually and electronically while the tester listens for any noise or malfunction.

### **12.01 Warranty**

Standard warranty shall be 12 months from date of installation or 18 months from date of manufacture. Warranty repairs shall be provided by an authorized service station.

#### **V7D Series Specification Data**

Discharge: 4"                      Solids: 4"

Wholesale Products Page: **JP10084SSD-6**

Section: **Specification Data**

Dated: **January, 2011**