

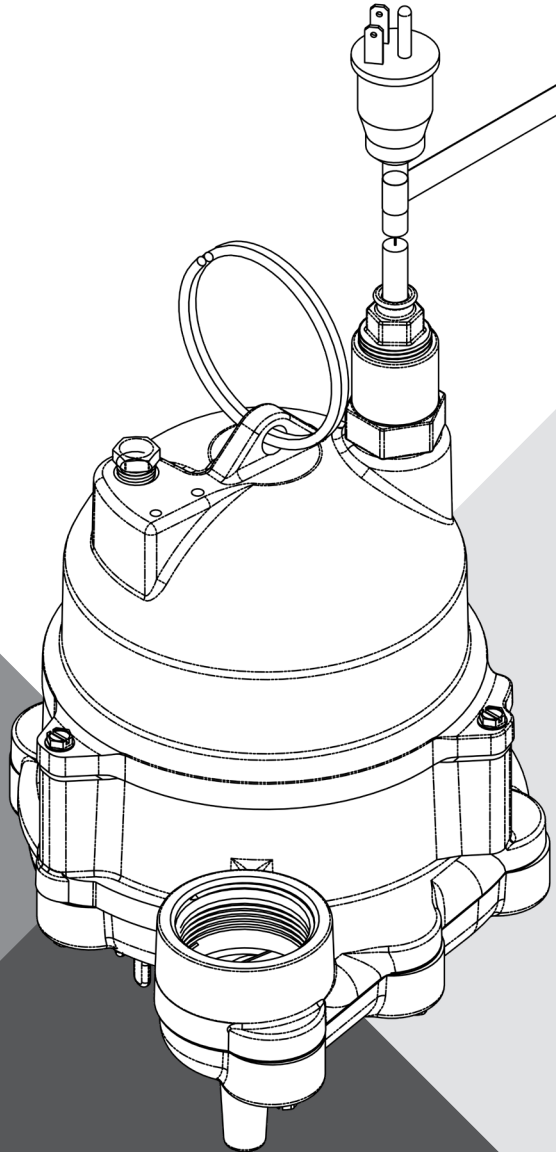

SUBMERSIBLE SUMP PUMPS SERIES MDC



INSTALLATION AND OPERATION MANUAL

pentair.com

TABLE OF CONTENTS

INTRODUCTION

Safety Instructions 3

Specifications..... 4

Installation..... 5

Operation / Maintenance 6

Parts Breakdown 7

Troubleshooting..... 8

Warranty 11

SAFETY INSTRUCTIONS

SAFETY SYMBOLS

 This is the safety alert symbol. When you see this symbol on your pump or in this manual, look for one of the following signal words and be alert to the potential for personal injury:

 **DANGER** warns about hazards that will cause serious personal injury, death or major property damage if ignored.

 **WARNING** warns about hazards that can cause serious personal injury, death or major property damage if ignored.

 **CAUTION** warns about hazards that will or can cause minor personal injury or property damage if ignored.

The word **NOTICE** indicates special instructions that are important but not related to hazards.

GENERAL SAFETY

- ◆ Carefully read and follow all safety instructions in this manual and on the unit itself.
- ◆ Follow all applicable local and state codes and regulations.
- ◆ Keep safety labels in good condition, replacing any missing or damaged labels.
- ◆ Vent sewage or septic tank according to local codes.
- ◆ Do not install pump in any location classified as hazardous by National Electrical Code, ANSI/NFPA 80-1984 or the Canadian Electrical Code.

 **WARNING HAZARDOUS VOLTAGE. CAN SHOCK, BURN, OR KILL.**

During operation the pump is in water. To avoid fatal shocks, proceed as follows if pump needs servicing:

- ◆ Do not smoke or use devices that can generate sparks in a septic (gaseous) environment.
- ◆ Disconnect power to outlet box before unplugging pump.
- ◆ Take extreme care when changing fuses. Do not stand in water or put your finger in the fuse socket.
- ◆ Do not modify the cord or plug. When using cord and plug, use a grounded outlet only. When wiring to a system control, connect ground lead to the system ground.
- ◆ Be sure that construction and access to septic sumps conform with all OSHA requirements.
- ◆ Do not run the pump dry. Dry running can overheat the pump, (causing burns to anyone handling it) and will void the warranty.
- ◆ The pump normally runs hot. To avoid burns when servicing pump, allow it to cool for 20 minutes after shutdown before handling it.
- ◆ The pump is permanently lubricated. No oiling or greasing is required in normal operation. For overhaul, see instructions under this manual's Maintenance section.

CALIFORNIA PROPOSITION 65 WARNING:

 **WARNING** This product and related accessories contain chemicals known to the State of California to cause cancer, birth defects or other reproductive harm.

ELECTRICAL SAFETY

 **DANGER HAZARDOUS VOLTAGE. CAN SHOCK, BURN, OR KILL.**

When installing, operating, or servicing this pump, follow the safety instructions listed below.

- ◆ DO NOT splice the electrical power cord.
- ◆ DO NOT allow the plug on the end of the electrical cord to be submerged.
- ◆ DO NOT use extension cords. They are a fire hazard and can reduce voltage sufficiently to prevent pumping and/or damage motor.
- ◆ DO NOT handle or service the pump while it is connected to the power supply.
- ◆ DO NOT remove the grounding prong from the plug or modify the plug. To protect against electrical shock, the power cord is a three-wire conductor and includes a 3-prong grounded plug. Plug the pump into a 3-wire, grounded, grounding-type receptacle. Connect the pump according to the NEC or CEC and local codes.
- ◆ BE SURE that power supply information (Voltage/ Hertz/ Phase) on pump motor nameplate matches incoming power supply exactly. Install pump according to all electrical codes that apply.

Before installing your pump, check carefully for shipping damage. Any claim for shipping damage must be made with your supplier at the point of purchase. **The manufacturer cannot make shipping damage adjustments.**

SPECIFICATIONS

SPECIFICATIONS

Power supply required115V, 60 HZ.
 Liquid Temp. Range32°F to 130°F (0°-54°C)
 Individual Branch MDC33 Series15 Amps
 Circuit Required: MDC50 Series 20 Amps
 Discharge Adapter 1-1/2" NPT

PERFORMANCE

GPM (LPM) AT TOTAL FEET (M)						
MODEL	5 (1.5M)	10 (3)	15 (4.6)	20 (6.1)	25 (7.6)	NO FLOW AT HEIGHT SHOWN BELOW
CAPACITY GALLONS (LITERS)/MINUTE						
MDC33	48 (182)	40 (151)	28 (106)	15 (57)	-	24 ft. (7.3m)
MDC50	62 (235)	53 (201)	47 (178)	38 (144)	28 (106)	32 ft. (9.8m)

MOTOR, CORD, & SWITCH SPECIFICATIONS

MODEL NUMBER	MOTOR HP	FULL LOAD AMPS	INDIVIDUAL BRANCH CIRCUIT REQUIRED (AMPS)	CORD LENGTH	SWITCH SETTING IN INCHES (MM)	
					ON	OFF
MDC33D10	1/3	9.8	15	10' (3 m)	8.5" (216)	4" (102)
MDC33M10	1/3	9.8	15	10' (3 m)	N/A	N/A
MDC33MCI10	1/3	9.8	15	10' (3 m)	N/A	N/A
MDC33T10	1/3	9.8	15	10' (3 m)	12.5" (318)	3.5" (89)
MDC33T20	1/3	9.8	15	20' (6,1 m)	12.5" (318)	3.5" (89)
MDC33TCI20	1/3	9.8	15	20' (6,1 m)	12.5" (318)	3.5" (89)
MDC33TCI10	1/3	9.8	15	10' (3 m)	12.5" (318)	3.5" (89)
MDC33V10	1/3	9.8	15	10' (3 m)	6.5" (165)	2" (51)
MDC33V20	1/3	9.8	15	20' (6,1 m)	6.5" (165)	2" (51)
MDC33VCI10	1/3	9.8	15	10' (3 m)	6.5" (165)	2" (51)
MDC50T10	1/2	12.0	20	10' (3 m)	12.5" (318)	3.5" (89)
MDC50T20	1/2	12.0	20	20' (6,1 m)	12.5" (318)	3.5" (89)
MDC50TCI10	1/2	12.0	20	10' (3 m)	12.5" (318)	3.5" (89)
MDC50TCI20	1/2	12.0	20	20' (6,1 m)	12.5" (318)	3.5" (89)
MDC50V10	1/2	12.0	20	10' (3 m)	6.5" (165)	2" (51)
MDC50V20	1/2	12.0	20	20' (6,1 m)	6.5" (165)	2" (51)
MDC50VCI10	1/2	12.0	20	10' (3 m)	6.5" (165)	2" (51)

INSTALLATION

INSTALLATION

1. Install the pump in a sump pit with a minimum diameter of 10" (254 mm) for models equipped with vertical switches, 12" (305 mm) for diaphragm float switch models and 14" (356 mm) for tethered float switch models. The sump depth should be 15" minimum (381mm). Construct the sump pit of tile, concrete, steel or plastic. Check the local codes for approved materials.
2. When installing the vertical switch, the rod stop (Ref. No. 1F, Repair Parts) must not be pushed up farther than the bottom nib on the float rod. Pushing it any farther up the rod will cause the switch to hang up on the pump discharge and will damage the pump.
3. The pump should not be installed on clay, earth or sand surfaces. Clean the sump pit of small stones and gravel which could clog the pump.
4. Install the pump in the pit so that the switch mechanism has maximum possible clearance.
5. Install the discharge plumbing. When using rigid pipe, use plastic pipe. Wrap the threads with PTFE tape. Screw the pipe into the pump hand tight +1 - 1-1/2 turns.

NOTICE: Do not use ordinary pipe joint compound on plastic pipe. Pipe joint compound can attack plastics and damage the pump.

CAUTION Risk of flooding. If a flexible discharge hose is used, make sure the pump is secure in the sump to prevent movement. Failure to secure the pump may allow pump movement, switch interference and prevent the pump from starting or stopping.

6. To reduce motor noise and vibrations, a short length of rubber hose (e.g. radiator hose) can be connected into the discharge line near the pump using suitable clamps.
7. Install an in-line check valve to prevent backward flow through the pump when the pump shuts off.
8. Power Supply: The pump is designed for 115 V., 60 Hz., operation and requires a minimum 15 amp (1/3 HP) or 20 amp (1/2 HP) individual branch circuit (refer to Motor, Switch and Cord Specifications). Both the pump and switch are supplied with 3-wire cord sets with grounding-type plugs. The switch plug is inserted directly into the outlet and the pump plug inserts into the opposite end of the switch plug.

WARNING Hazardous voltage. Can shock, burn or kill. The pump should always be electrically grounded to a suitable electrical ground such as a grounded water pipe or a properly grounded metallic raceway, or ground wire system. Do not modify the cord or plug or cut off the round ground pin.

9. If the pump discharge line is exposed to an outside sub-

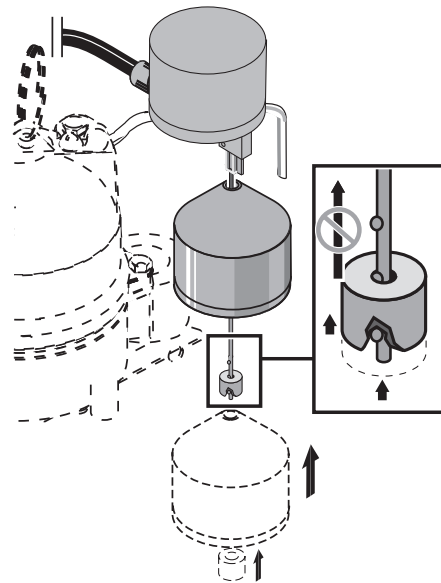

Figure 1

freezing atmosphere, the portion of the line exposed must be installed so any water remaining in the pipe will drain to the outfall by gravity. Failure to do this can cause the water trapped in the discharge to freeze which could result in damage to the pump.

10. After the piping and check valve have been installed, the unit is ready for operation.
11. Check the operation by filling the sump with water and observing pump operation through one complete cycle.

CAUTION Risk of Flooding. Failure to make this operational check may lead to improper operation, premature failure, and flooding.

OPERATION / MAINTENANCE

⚠ WARNING Risk of electrical shock. Can burn or cause death. Do not handle a pump or pump motor with wet hands or when standing on a wet or damp surface, or in water.

Before attempting to check why unit has stopped operating, disconnect power from unit.

⚠ WARNING Risk of fire and explosion. Can cause severe injury, property damage or death. Do not use in explosive atmospheres. Pump water only with this pump.

1. The shaft seal depends on water for lubrication and cooling. Do not operate the pump unless it is submerged in water as the seal may be damaged if allowed to run dry.
2. The motor is equipped with an automatic reset thermal protector. If the temperature in the motor should rise unduly, the switch will cut off all power before damage can be done to the motor. When the motor has cooled sufficiently, the switch will reset automatically and restart the motor. If the protector trips repeatedly, the pump should be removed and checked as to cause of difficulty. Low voltage, long extension cords, clogged impeller, very low head or lift, etc., could cause cycling.
3. The pump will not remove all water. If a manually operated pump is operating and suddenly no water comes out of the discharge hose, shut the unit off immediately. The water level is probably very low and the unit has broken prime.

NOTICE: Do not change the tether length of the float switch. The float must be able to swing through its complete arc without interference.

AIRLOCKS

When a pump airlocks, it runs but does not move any water. An airlock will cause the pump to overheat and fail. These pumps have a built in anti-airlock hole. See Repair Parts for the location of the hole. Leakage from the anti-airlock hole is normal.

If you suspect an airlock, unplug the pump, clean out the anti-airlock hole with a paper clip or a piece of wire, and restart the pump.

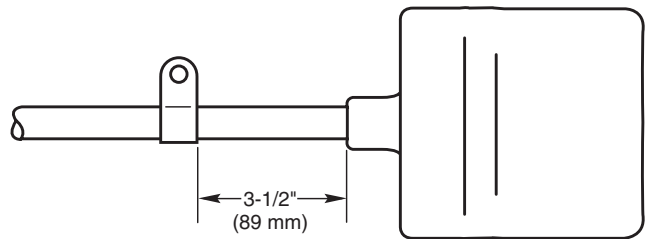
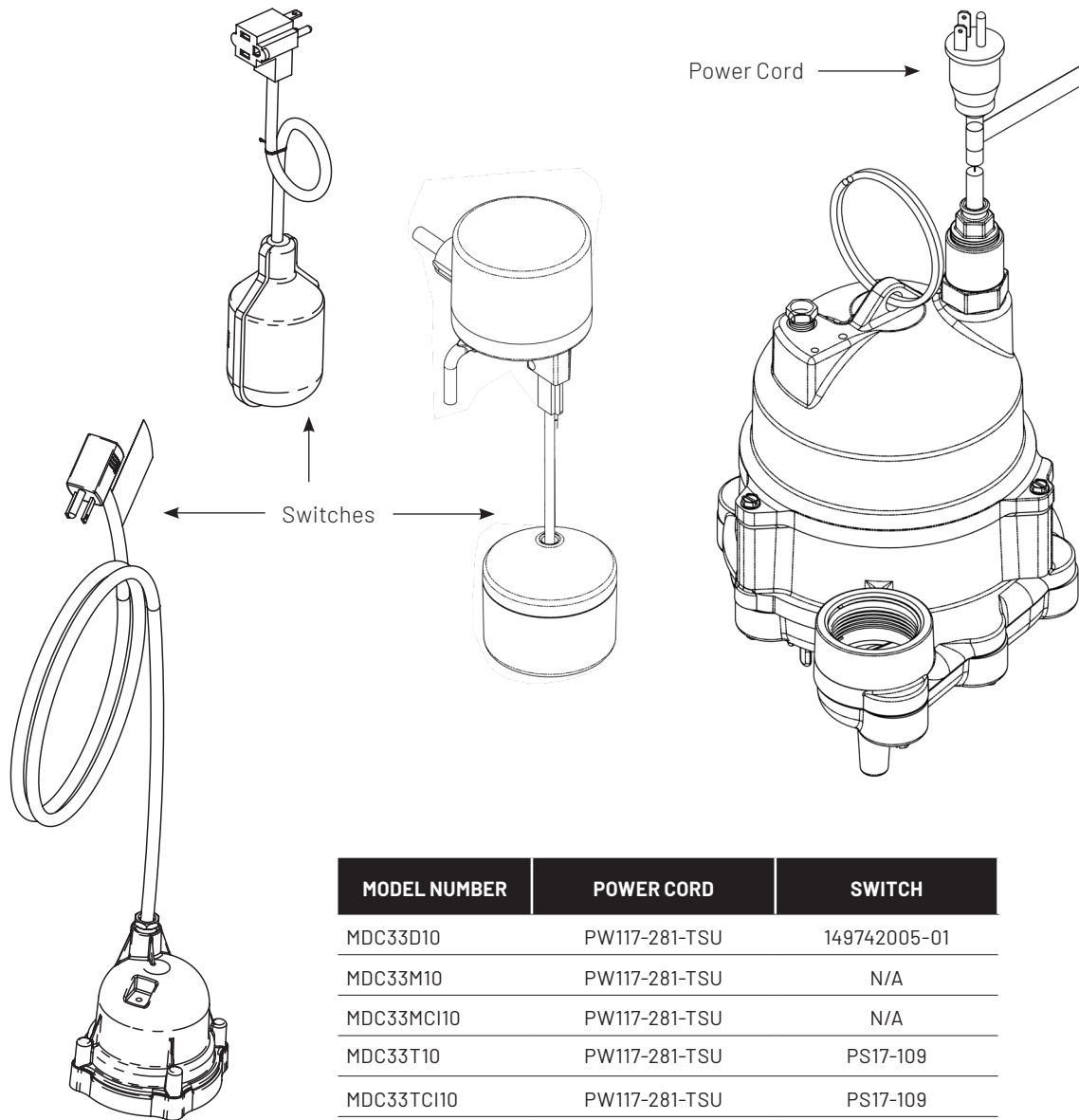

Figure 2

PARTS BREAKDOWN



MODEL NUMBER	POWER CORD	SWITCH
MDC33D10	PW117-281-TSU	149742005-01
MDC33M10	PW117-281-TSU	N/A
MDC33MC110	PW117-281-TSU	N/A
MDC33T10	PW117-281-TSU	PS17-109
MDC33TCI10	PW117-281-TSU	PS17-109
MDC33T20	PW117-122-TSU	PS17-111
MDC33TCI20	PW117-122-TSU	PS17-111
MDC33V10	PW117-281-TSU	PKG 208
MDC33VCI10	PW117-281-TSU	PKG 208
MDC33V20	PW117-122-TSU	PS117-2127
MDC50T10	PW117-237-TSU	PS17-109
MDC50TCI10	PW117-237-TSU	PS17-109
MDC50T20	PW117-122-TSU	PS17-111
MDC50TCI20	PW117-122-TSU	PS17-111
MDC50V10	PW117-237-TSU	PKG 208
MDC50VCI10	PW117-237-TSU	PKG 208
MDC50V20	PW117-122-TSU	PKG 209

TROUBLESHOOTING

SYMPTOM	PROBABLE CAUSE(S)	CORRECTIVE ACTION
Pump won't start or run.	Blown fuse.	If blown, replace with a fuse of proper size.
	Low line voltage.	If the voltage is under the recommended minimum, check the size of the wiring from the main switch on the property. If OK, contact power company or hydro authority.
	Defective motor.	Replace the pump.
	Defective float switch.	Replace the float switch.
	Impeller.	If the impeller won't turn, remove the lower pump body and locate the source of the binding.
	Float is obstructed.	Remove the obstruction.
Pump starts and stops too often.	Backflow of water from piping.	Install or replace the check valve.
	Faulty float switch.	Replace the float switch.
Pump won't shut off.	Defective float switch.	Replace the float switch.
	Restricted discharge (obstacle in piping).	Remove the pump and clean the pump and piping.
	Float obstructed.	Remove the obstruction.
Pump operates but delivers little or no water.	Low line voltage.	If the voltage is under the recommended minimum, check the size of the wiring from the main switch on the property. If OK, contact power company or hydro authority.
	Something is caught in impeller.	Clean out the impeller.
	Anti-airlock hole is plugged.	Turn off the pump, clean out the anti-airlock hole, and restart pump.

INTENTIONALLY LEFT BLANK

INTENTIONALLY LEFT BLANK

WARRANTY

LIMITED WARRANTY

Myers® warrants to the original consumer purchaser (“Purchaser” or “You”) of the products listed below, that they will be free from defects in material and workmanship for the Warranty Period shown below.

PRODUCT	WARRANTY PERIOD WHICHEVER OCCURS FIRST:
Jet pumps, small centrifugal pumps, submersible pumps and related accessories	12 months from date of original installation, or 18 months from date of manufacture
Fibrewound Tanks	5 years from date of original installation
Steel Pressure Tanks	5 years from date of original installation
Sump/Sewage/Effluent Products	12 months from date of original installation, or 36 months from date of manufacture
Battery Backup Units MBSP-2, MBSP-2C	12 months from date of original installation, or 18 months from date of manufacture
MBSP-3, MBSP-3C	24 months from date of original installation, or 30 months from date of manufacture
Wastewater Solids Handling Pumps	12 months from date of shipment from factory or 18 months from date of manufacture

Our warranty applies only where such products are used in compliance with the requirements of the applicable product catalog and/or manuals. For additional information, please refer to the applicable standard limited warranty featured in the product manual.

Our warranty will not apply to any product that, in our sole judgement, has been subject to negligence, misapplication, improper installation, or improper maintenance. Without limiting the foregoing, operating a three phase motor with single phase power through a phase converter will void the warranty. Note also that three phase motors must be protected by three-leg, ambient compensated, extra-quick trip overload relays of the recommended size or the warranty is void.

Your only remedy, and MYERS’s only duty, is that MYERS repair or replace defective products (at MYERS’s choice). You must pay all labor and shipping charges associated with this warranty and must request warranty service through the installing dealer as soon as a problem is discovered. No request for service will be accepted if received after the Warranty Period has expired. This warranty is not transferable.

MYERS SHALL NOT BE LIABLE FOR ANY CONSEQUENTIAL, INCIDENTAL, OR CONTINGENT DAMAGES WHATSOEVER.

THE FOREGOING LIMITED WARRANTIES ARE EXCLUSIVE AND IN LIEU OF ALL OTHER EXPRESS AND IMPLIED WARRANTIES, INCLUDING BUT NOT LIMITED TO IMPLIED WARRANTIES OF MERCHANTABILITY AND FITNESS FOR A PARTICULAR PURPOSE. THE FOREGOING LIMITED WARRANTIES SHALL NOT EXTEND BEYOND THE DURATION PROVIDED HEREIN.

Some states do not allow the exclusion or limitation of incidental or consequential damages or limitations on the duration of an implied warranty, so the above limitations or exclusions may not apply to You. This warranty gives You specific legal rights and You may also have other rights which vary from state to state.

This Limited Warranty is effective April 1, 2014 and replaces all undated warranties and warranties dated before April 1, 2014.

F.E. MYERS
293 Wright Street, Delavan, WI 53115
Phone: 888-987-8677 • Fax: 800-426-9446 • www.femyers.com
In Canada: 490 Pinebush Road, Unit 4, Cambridge, Ontario N1T 0A5
Phone: 800-363-7867 • Fax: 888-606-5484



AMERICAS
1101 Myers Parkway
Ashland, Ohio 44805
PH: 855-274-8947

CANADA
490 Pinebush Road,
Unit 4
Cambridge, Ontario,
Canada N1T 0A5
PH: 800-363-7867

pentair.com

All indicated Pentair trademarks and logos are property of Pentair. Third party registered and unregistered trademarks and logos are the property of their respective owners. Because we are continuously improving our products and services, Pentair reserves the right to change specifications without prior notice. Pentair is an equal opportunity employer.

MY1048 (05/01/21) ©2021 Pentair. All Rights Reserved.