

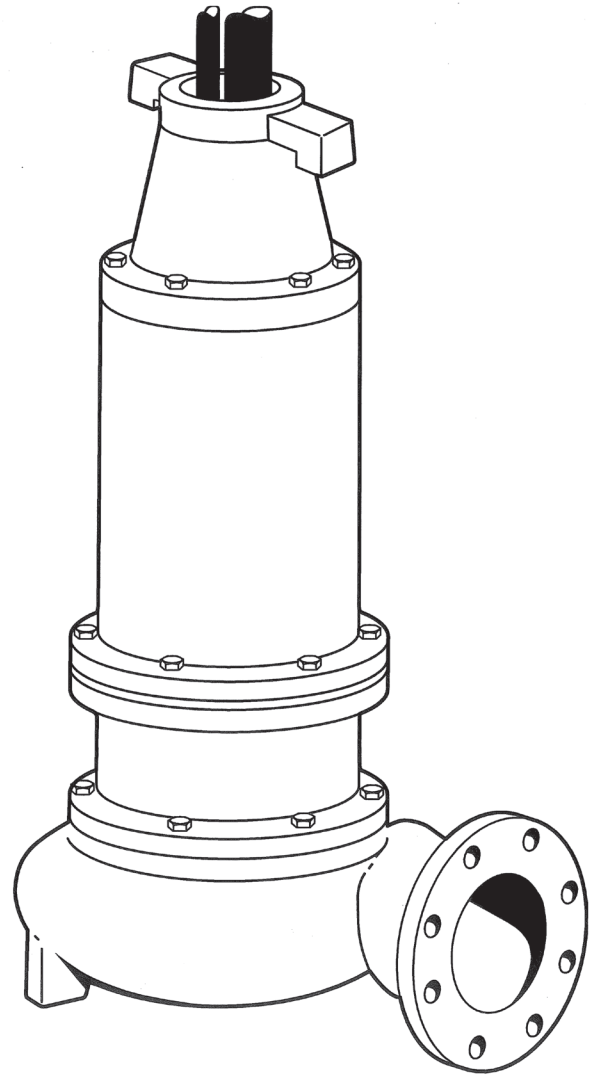

MYERS®



MODELS 4VC(X*), 6VC(X*), 4VE(X*) AND 4RC(X*)

*Used in Hazardous Locations Class I, Division 1, Groups C & D

SUBMERSIBLE SOLIDS HANDLING PUMPS

INSTALLATION AND SERVICE MANUAL

For use with product built with USEM motor.

NOTE! To the installer: Please make sure you provide this manual to the owner of the equipment or to the responsible party who maintains the system.



CAUTION!

Read these safety warnings first before installing, servicing or operating any pump.

CALIFORNIA PROPOSITION 65 WARNING:

▲ WARNING This product and related accessories contain chemicals known to the State of California to cause cancer, birth defects or other reproductive harm.

GENERAL

1. Most accidents can be avoided by using **COMMON SENSE**.
2. Read the operation and maintenance instruction manual supplied with the pump.
3. Do not wear loose clothing that can become entangled in the impeller or other moving parts.
4. This pump is designed to handle materials that could cause illness or disease through direct exposure.

Wear adequate protective clothing when working on the pump or piping.

ELECTRICAL

5. To reduce the risk of electrical shock, pump must be properly grounded in accordance with the National Electric Code and all applicable state and local codes and ordinances.
6. To reduce risk of electrical shock, disconnect the pump from the power source before handling or servicing.
7. Any wiring to be done on pumps should be done by a qualified electrician.
8. Never operate a pump with a power cord that has frayed or brittle insulation.
9. Never let cords or plugs lie in water.
10. Never handle connected power cords with wet hands.

PUMPS

11. Pump builds up heat and pressure during operation; allow time for pump to cool before handling or servicing.
12. Only qualified personnel should install, operate or repair pump.
13. Keep clear of suction and discharge openings. **DO NOT** insert fingers in pump with power connected.
14. Do not pump hazardous material not recommended for pump (flammable, caustic, etc.).
15. Make sure lifting handles are securely fastened each time before lifting.
16. Do not lift pump by the power cord.

17. Do not exceed manufacturer's recommendation for maximum performance, as this could cause the motor to overheat.
18. Secure the pump in its operating position so it cannot tip over, fall or slide.
19. Keep hands and feet away from impeller when power is connected.
20. Submersible solids handling pumps are not approved for use in swimming pools, recreational water installations, decorative fountains or any installation where human contact with the pumped fluid is common.
21. Do not operate pump without safety devices in place.

IMPORTANT! Myers is not responsible for losses, injury or death resulting from a failure to observe these safety precautions, misuse or abuse of pumps or equipment.

GENERAL INFORMATION:

Pump Models: These instructions cover the installation and service of the Myers pumps as listed on the front cover. The hazardous location models are Factory Mutual approved and listed hazardous location for hazardous sewage locations Class 1, Division 1, Groups C & D.

Motor HP & Voltages: These pumps are offered in a three phase wiring configuration only. Voltages will vary according to the application.

Electrical Controls: All of these pump models must be used with a control panel. Myers built control panels are designed to supply the correct electrical controls, motor starting equipment and include the circuitry for moisture and heat sensors. It is recommended that a Myers built control panel be used so that all warranties apply.

General Construction: The motor construction is designed to meet Factory Mutual's requirements for Class 1, Division 1, Groups C & D sewage applications. The hazardous location models are certified and nameplated with this approval. The motor chamber and seal chamber are filled with a high dielectric type oil for improved lubrication and heat transfer of the bearings and motor. Since the bearings have been designed for 50,000 hours of life, the oil should never require replacement under normal operating conditions. An air space above the oil level in both the seal and motor chambers is provided to allow for the expansion of the oil when at operating temperature. The power and control lines are sealed and strain relieved by a grommet in the cord cap, and internally through the use of a dielectric potting resin surrounding the electrical wires. All of the pump fasteners and shafts are made from corrosion resistant stainless steel, while the pump castings are made of ASTM A-48 Class 30 cast iron. The wear ring is brass and all impellers are two vane enclosed solids handling design made from ductile iron.

General Installation: Various configurations and methods of plumbing this series of solids handling pumps may be used; however, for ease of installation and service a Myers 4" rail lift-out system is recommended.

Note: If the hazardous location pumps are used in conjunction with a rail lift-out system, it must be an F.M. approved nonsparking, hazardous location system. The Myers approved lift-out models are:

<u>4" Liftout</u>	<u>6" Liftout</u>
SRAX44HH	SRAX66

If these guidelines are not followed, the Factory Mutual approval is void.

Hazardous Location Service: These pumps are to be used for handling sewage, wastewater and storm water only. Do not use in other hazardous locations. These pumps must be repaired and serviced only at Myers Authorized Service Centers or at the Myers factory. Any unauthorized field repair voids warranty, hazardous location rating and Factory Mutual approval.

CAUTION: After the pump is installed and sewage has entered the basin there are methane and hydrogen sulfide gases, which are poisonous. Never enter a wet well unless the cover is open for a sufficient period of time to allow fresh air into the basin. Myers recommends using the rail lift-out system so that no service is required inside the basin.

Motor: Each motor is provided with heat sensor thermostats attached directly to the motor windings. The thermostats open if the motor windings see excessive heat and, in turn, open the motor contactor in the control panel, breaking the power to the pump. When the motor is stopped due to an overheated condition, it will not start until the motor has cooled and the heat sensor reset button is manually pushed on the front of the Myers control panel. This circuitry is provided in the Myers control panel designs.

Thermostats are set to open at a temperature of 248°F (120°C). The maximum contact rating is 18 amps at 115 VAC and 12 amps at 230 VAC. Motor winding insulation is good for Class H (356°F, 180°C).

Note: Failure to use proper circuitry and to connect the motor overheat protection in the control panel would negate all warranties and F.M. approval.

Motor Seal Failure Warning: The seal chamber is oil filled and provided with moisture sensing probes to detect water leakage through the lower shaft seal. The probes can also detect moisture present in the upper motor housing.

The presence of water energizes a red seal leak warning light at the control panel. This is a warning light only, and does not stop the motor. It indicates a leak has occurred and the pump must be repaired.

Normally, this indicates the outboard seal has leaked. Allowing the unit to operate after the warning could cause upper seal leakage along with motor failure.

The resistance across the moisture sensing (seal failure) probes should be checked after a seal leak warning light has lit. This can be done by disconnecting the red and orange control wires from the control panel and measuring the resistance with an ohmmeter between the wires. If the measured values are below specification, the pump may have a lower seal failure and require service.

On the Myers hazardous location control panels the seal leak test switch tests the seal leak circuit continuity. When pushed the seal leak test bulb should light. If the test bulb does not light it means either the wiring circuitry to the seal leak probes has been broken or the bulb has burned out.

Note: Myers built control panels supply the correct circuitry for moisture and heat sensor connections. Failure to install the correct circuitry with proper connection would negate warranty and F.M. approval.

Motor Power Cord, Control Cord and Cord Cap Assembly: Each motor power cord has 4 conductors - white, black, red and green. For a three phase motor the red, black and white conductors connect to the three line leads, and the green is connected to a good ground. Interchanging any two line leads will reverse the rotation of the motor.

Note: Rotation should be clockwise when observed from the top of the pump. This can be checked by noting which direction the pump torque is up on initial starting. A properly rotating pump will torque counterclockwise upon start.

The control cable has 5 conductors - black, white, red, orange and green. White and black connect to the heat sensor terminals in the control panels; red and orange connect to the seal failure terminals in the control panel; and the green connects to the ground in the control panel.

The cord cap is epoxy potted. The cord cap provides for a sealed wire connection. This allows the cord cap, with cords, to be removed from the motor. An approved hazardous location junction box is required for hazardous locations. The control and power cables cannot be spliced!

Note: Each cable has a green ground wire and must be properly grounded per the National Electric Code and local codes.

Electrical Motor Controls: All electrical controls and motor starting equipment should be as specified in these instructions. Consult factory for any acceptable alternatives. For hazardous locations the controls and control panel must be installed outside the hazardous area, or approved hazardous location controls that are intrinsically safe must be used.

Junction Box: If a junction box is used in a hazardous location, it must be a hazardous location approved type with hazardous location cord connectors. Wires from the junction box must pass through a hazardous location seal connector.

Level Sensing Controls: Intrinsically safe type float controls are recommended for all applications and required for hazardous location service. An intrinsically safe control panel relay will limit the current and voltage to the level controls. A Myers control panel can be supplied with this type circuitry.

The float level controls maintain the basin sewage water level by controlling pump turn-on and turn-off levels.

1. The lower turn-off control should be set so that the pump stops at approximately the top of the pump. Consult the factory for any settings below this point.
2. The upper turn-on control should be set above the lower turn-off control. The exact height between the two controls is determined by the number of pump starts desired and the depth of the basin. A maximum of 10 starts per hour should not be exceeded.
3. The override control is set at a specified height above the upper turn-on control.
4. The alarm control is set about 6" to 12" above the override control.
5. No control should be set above the inlet invert.

Electrical Connections: All electrical wiring must be in accordance with local code and only qualified electricians should make the installations. All wires should be checked for shorts to ground with an ohmmeter or megger after the connections are made. This is important, as one grounded wire can cause failure of the pump, control panel or personal injury.

WARNING: Disconnect pump from power source before servicing or handling pump.

Disassembly

1. With the pump located in a secure place, remove the bolts fastening the seal housing to the volute. The motor and impeller can now be removed as a unit.
2. Lay the unit down on its side. If the lower seal is to be removed, it is recommended that the oil in the seal chamber be drained. This can be done by removing the lower seal chamber plug and draining the oil into a holding container.
3. To remove the impeller: Using a proper wrench, the impeller retaining bolt and washer must be removed. This may require a piece of wood placed between the vanes to keep the impeller from rotating while removing the bolt. Once the bolt has been removed, tap lightly with a hammer around

the outside diameter of the impeller to loosen from shaft and key. After removing impeller, the seal retainer needs to be removed to expose seal.

Caution: The impeller is large and heavy and will need to be supported.

4. If the lower seal needs removed, first remove the compression spring that rides between the impeller and the seal assembly. Next take a pair of screwdrivers and remove the compression ring that surrounds the rubber bellows on the rotating portion of the seal assembly. Again using the screwdrivers, pry the remaining portion of the rotating seal assembly off the shaft. The ceramic stationary can be removed by placing a screwdriver between the rubber and the ceramic face, and then prying, working around the entire diameter. Note, these parts should be discarded and a new seal assembly installed.
5. If the oil in the seal chamber was drained, examine the contents to determine if the upper seal has been damaged. Signs of grit or other abrasive material may indicate that the upper seal has also been damaged. Pressurizing the motor housing assembly between 7 and 10 psi and observing any drop in pressure will indicate if the upper seal is functioning properly.
Note: Upper seal repairs must be done at a Myers Authorized Service Center or at the Myers factory. Any unauthorized field repair voids warranty and the hazardous location approval on the F.M. listed pump.
6. The wear ring can be removed from the volute for repair or replacement. First remove the retaining screws from the wear ring. With a soft mallet the wear ring can be tapped out of the volute case.

Reassembly

1. Remove the ceramic portion of the new seal from the package. Brush new dielectric oil around the rubber portion of the stationary assembly and into the pocket in the seal housing. Note, keep the oil off the seal face. Without scratching the seal face, press the ceramic stationary portion into the seal housing using a Myers seal pusher. With a clean cloth, lightly wipe the face of the seal surface to make sure it is dirt free. Remove the rotating portion of the seal from the package and lubricate the inside diameter of the rubber bellows and the outside diameter of the shaft. Place the seal over the shaft (make sure the key is removed). Evenly press on the body of the rotational assembly and slide it down the shaft until the seal faces meet. Once the seal assembly is in position, place the spring over the register on the rotational portion of the seal.
2. Before placing impeller on shaft, the seal spring retainer should be placed on shaft with stepped end toward seal spring. Position the key into the seat in the shaft. Align the impeller onto the shaft, making sure that the seal spring is registered

- properly onto the back side of the impeller. Insert the bolt and washer assembly into the shaft and tighten.
- Fill the seal chamber with new dielectric oil. An air gap of 10–15% volume must be left for the expansion of the oil when it is at operating temperature.
 - The wear ring can be aligned with the retaining holes and tapped into place with a soft mallet. The proper Loctite® should be applied to the bolts. Install and tighten.

- The motor and impeller assembly can be installed into the volute. Make sure that the impeller aligns properly with the volute. Install the volute retaining bolts and tighten.
- Air tends to trap in the pump case when water rises in the sump or when the pump is lowered into the water after service. To vent off this air, a small hole is drilled into the volute casting. Be sure this vent hole is clean after any service work on pump. Air venting is not a problem after initial start.

WIRING DIAGRAMS

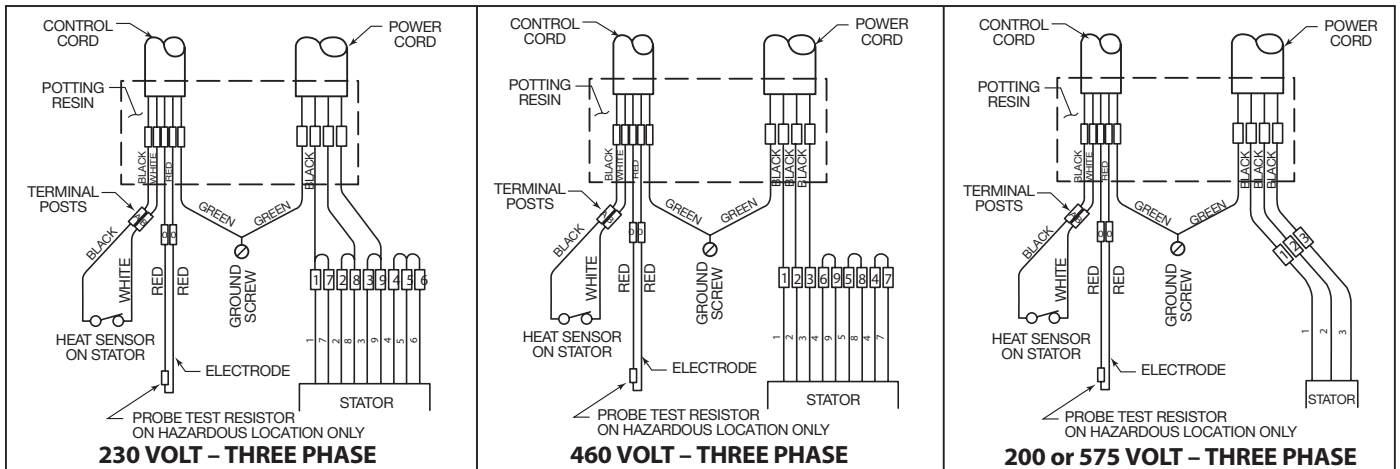

CHECK LIST IF PUMP DOES NOT OPERATE PROPERLY

Checking for Moisture in Motor: Use an ohmmeter or a megger and set on highest scale. Readings on the large power cord between any of the conductors red, black or white to the green conductor or to the motor housing should be greater than 1,000,000 ohms (1 megohm). Service work should be done only at an authorized service station. Note, readings should be taken with line leads disconnected from the control panel.

Resistance of Windings: Every motor winding has a fixed resistance. The windings must check close to specification values. Verification of the proper wiring of a dual voltage motor can also be checked by measuring the motor winding resistance.

CONDITION

Red light comes on at control box.

PROBABLE CAUSE

This indicates some water has leaked past the lower seal and has entered the seal chamber and made contact with the electrode probe. Pump must be removed for replacement of lower seal. This preventative repair will save an expensive motor.

Overload trips at control box and alarm buzzer or flashing red light comes on due to high water level in basin.

- Push in on red reset button to reset overload. If overload trips again after short run, pump has some damage and must be removed from basin for checking.
- Trouble may be from clogged impeller causing motor to overload or could be from failed motor.
- Trouble may be from faulty component in control box. Always check control box before removing pump.

CONDITION	PROBABLE CAUSE
Yellow run light stays on continuously.	<ol style="list-style-type: none"> 1. Indicates H-O-A switch may be in the hand position. 2. Level control switch may have failed causing pump to continue to operate when water is below lower control. 3. Impeller may be partially clogged causing pump to operate at very reduced capacity. 4. Gate valve or check valve may be clogged causing low pump flow. 5. Pump may be air locked.
Circuit breaker trips.	<ol style="list-style-type: none"> 1. Reset breaker by pushing completely down on handle then back to ON position. If breaker trips again in few seconds it indicates excessive load probably caused by a short in the motor or control box. Check out instructions given with control box before pulling pump. 2. If this condition happens after an electrical storm, motor or control box may be damaged by lightning. 3. Resistance reading of the motor with lead wires disconnected from the control box can determine if trouble is in motor or control box.
Pump is noisy and pump rate is low.	<ol style="list-style-type: none"> 1. Impeller may be partially clogged with some foreign objects causing noise and overload on the motor. 2. Impeller may be rubbing on wear ring due to bent shaft or misalignment. 3. Pump may be operating too close to shut-off. Check head.
Grease and solids have accumulated around pump and will not pump out of basin.	<ol style="list-style-type: none"> 1. Lower control switch may be set too high. 2. Run pump on hand operation for several minutes with small amount of water running into basin to clean out solids and grease. This allows pump to break suction and surge which will break up the solids. If level switch is set properly this condition generally will not occur. 3. Trash and grease may have accumulated around floats causing pump to operate erratically.

COMMON PARTS LIST

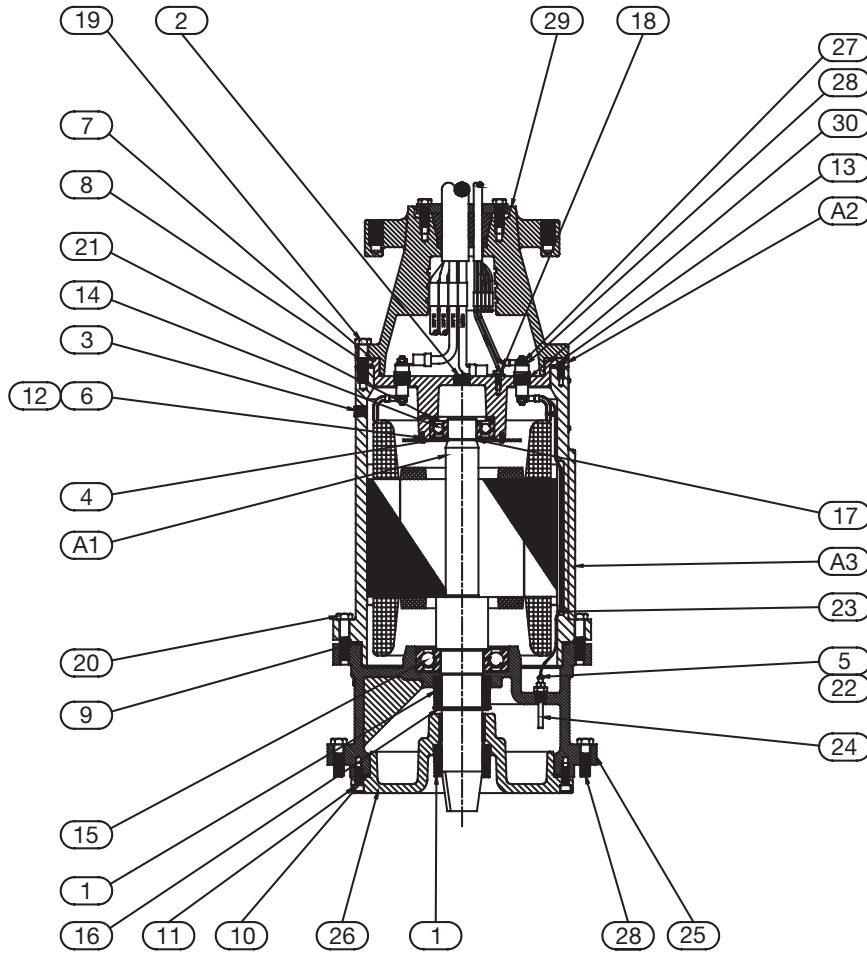

CAP SCREW	TORQUE VALUE
3/8-16	20 ft.-lbs.
1/2-13	43 ft.-lbs.
5/8-11	93 ft.-lbs.
3/4-10	128 ft.-lbs.
7/8-14	193 ft.-lbs.

ITEM	PART NO.	DESCRIPTION	QTY.
1	080730001	SEAL; SHAFT 2-1/4	2
2	05022A015	PLUG – PIPE ST GALV 1/2	1
3	05022A092	PLUG – PIPE ST GALV 1/4 HEX HD.	2
4	05030A214	WASHER – SUPPORT	1
5	05434A025	SCREW – MACH ST Z&D #6-32	2
6	055830011	SCREW – MACH (PAN HD) 10-24	4
7	05876A135	O-RING	1
8	05876A136	O-RING	1
9	05876A137	O-RING	1
10	05876A138	O-RING	1
11	06106A028	SCREW – CAP CKT HD SST	8
12	06107A015	WASHER – LOCK	4
13	07597A017	SCREW – MACH FT HD	2
14	08565A027	BEARING – BALL (UPPER)	1
15	000650381	BEARING – BALL (LOWER)	1
16	12558A020	RING – RETAINING EXTERNAL	1
17	12558A024	RING – RETAINING EXTERNAL	1
18	19099A003	SCREW – CAP HEX 1/4 SST	1
19	19103A047	SCREW – CAP HEX SST	8
20	19103A049	SCREW – CAP HEX SST	8
21	19331A008	WASHER – SPRING WAVE	2
22	22912A000	RESISTOR	1
23	22578A001	ELECTRODE 5-15 HP	2

ITEM	PART NO.	DESCRIPTION	QTY.
24	25343A100	PROBE – SEAL LEAK	2
25	23604D010	HOUSING-SEAL UPPER – ORDINARY LOCATION	1
	23604D010X	HOUSING-SEAL UPPER – HAZARDOUS LOCATION	1
26	23610D100	HOUSING-SEAL LOWER – ORDINARY LOCATION	1
	23610D100X	HOUSING-SEAL LOWER – HAZARDOUS LOCATION	1
27	11904A005	1/4-20 SST LOCK NUT – 3450 RPM	
	11904A037	1/4-20 SST LOCK NUT – 870, 1150, 1750 RPM	
28	19103A045	SCREW – CAP HEX SST 3/4, 4RC(X), 4VC(X), 6VC(X)	8
	19103A062	SCREW – CAP HEX SST 3/4, 4VE(X)	8
29	23549D031	35' CORD ASSEMBLY 10-4	1
	23549D032	35' CORD ASSEMBLY 8-4 SOOW	1
	23549D039	35' CORD ASSEMBLY 8-4 W	1
	23549D036	35' CORD ASSEMBLY 6-4	1
	23549D037	35' CORD ASSEMBLY 4-4	1
	23549D038	35' CORD ASSEMBLY 2-4	1
	23549D631	35' HAZARDOUS LOCATION CORD ASSEMBLY 10-4	1
	23549D632	35' HAZARDOUS LOCATION CORD ASSEMBLY 8-4 SOOW	1
	23549D639	35' HAZARDOUS LOCATION CORD ASSEMBLY 8-4 W	1
	23549D636	35' HAZARDOUS LOCATION CORD ASSEMBLY 6-4	1
	23549D637	35' HAZARDOUS LOCATION CORD ASSEMBLY 4-4	1
	23549D638	35' HAZARDOUS LOCATION CORD ASSEMBLY 2-4	1
	30	23555A000	TERMINAL

* Used in hazardous location pumps only.
 For pumps built prior to May 2012, consult factory for seal/seal housing components.

MOTOR PARTS

3450 RPM

Item	Description	20 HP	20 HP	20 HP	25 HP	25 HP	25 HP	30 HP	30 HP
		230/3/3450	460/3/3450	575/3/3450	230/3/3450	460/3/3450	575/3/3450	230/3/3450	460/3/3450
A1	ROTOR; W/SHAFT – ORDINARY LOCATION	26576D312	26576D312	26576D312	26576D312	26576D312	26576D312	26576D312	26576D312
	ROTOR; W/SHAFT – HAZARDOUS LOCATION	26576D312X	26576D312X	26576D312X	26576D312X	26576D312X	26576D312X	26576D312X	26576D312X
A2	HOUSING, BRG; UPPER	23557D011	23557D011	23557D010	23557D011	23557D011	23557D010	23557D011	23557D011
A3	HOUSING; & STATOR – HAZARDOUS LOCATION	23558E724	23558E724	23558E725	23558E724	23558E724	23558E725	23558E724	23558E724
	HOUSING; & STATOR – ORDINARY LOCATION	23558E324	23558E324	23558E325	23558E324	23558E324	23558E325	23558E324	23558E324

Item	Description	30 HP	40 HP	40 HP	50 HP	50 HP	60 HP	60 HP
		575/3/3450	460/3/3450	575/3/3450	460/3/3450	575/3/3450	460/3/3450	575/3/3450
A1	ROTOR; W/SHAFT – ORDINARY LOCATION	26576D312	26576D313	26576D313	26576D313	26576D313	26576D313	26576D313
	ROTOR; W/SHAFT – HAZARDOUS LOCATION	26576D312X	26576D313X	26576D313X	26576D313X	26576D313X	26576D313X	26576D313X
A2	HOUSING, BRG; UPPER	23557D010	23557D011	23557D010	23557D011	23557D010	23557D011	23557D010
A3	HOUSING; & STATOR – HAZARDOUS LOCATION	23558E725	23558E726	23558E727	23558E726	23558E727	23558E726	23558E727
	HOUSING; & STATOR – ORDINARY LOCATION	23558E325	23558E326	23558E327	23558E326	23558E327	23558E326	23558E327

1750 RPM

Item	Description	15 HP	15 HP	15 HP	15 HP	20 HP	20 HP
		200/3/1750	230/3/1750	460/3/1750	575/3/1750	200/3/1750	230/3/1750
A1	ROTOR; W/SHAFT – ORDINARY LOCATION	26576D307	26576D307	26576D307	26576D307	26576D307	26576D307
	ROTOR; W/SHAFT – HAZARDOUS LOCATION	26576D307X	26576D307X	26576D307X	26576D307X	26576D307X	26576D307X
A2	HOUSING, BRG; UPPER	23557D010	23557D011	23557D011	23557D010	23557D010	23557D011
A3	HOUSING; & STATOR – HAZARDOUS LOCATION	23558E755	23558E758	23558E758	23558E759	23558E755	23558E758
	HOUSING; & STATOR – ORDINARY LOCATION	23558E355	23558E358	23558E358	23558E359	23558E355	23558E358

Item	Description	20 HP	20 HP	25 HP	25 HP	25 HP	25 HP
		460/3/1750	575/3/1750	200/3/1750	230/3/1750	460/3/1750	575/3/1750
A1	ROTOR; W/SHAFT – ORDINARY LOCATION	26576D307	26576D307	26576D310	26576D310	26576D310	26576D310
	ROTOR; W/SHAFT – HAZARDOUS LOCATION	26576D307X	26576D307X	26576D310X	26576D310X	26576D310X	26576D310X
A2	HOUSING, BRG; UPPER	23557D011	23557D010	23557D010	23557D011	23557D011	23557D010
A3	HOUSING; & STATOR – HAZARDOUS LOCATION	23558E758	23558E759	23558E790	23558E762	23558E762	23558E763
	HOUSING; & STATOR – ORDINARY LOCATION	23558E358	23558E359	23558E390	23558E362	23558E362	23558E363

Item	Description	30 HP	30 HP	30 HP	30 HP	40 HP	40 HP
		200/3/1750	230/3/1750	460/3/1750	575/3/1750	230/3/1750	460/3/1750
A1	ROTOR; W/SHAFT – ORDINARY LOCATION	26576D310	26576D310	26576D310	26576D310	26576D310	26576D310
	ROTOR; W/SHAFT – HAZARDOUS LOCATION	26576D310X	26576D310X	26576D310X	26576D310X	26576D310X	26576D310X
A2	HOUSING, BRG; UPPER	23557D010	23557D011	23557D011	23557D010	23557D011	23557D011
A3	HOUSING; & STATOR – HAZARDOUS LOCATION	23558E790	23558E762	23558E762	23558E763	23558E764	23558E764
	HOUSING; & STATOR – ORDINARY LOCATION	23558E390	23558E362	23558E362	23558E363	23558E364	23558E364

Item	Description	40 HP	50 HP	50 HP	50 HP	60 HP	60 HP
		575/3/1750	230/3/1750	460/3/1750	575/3/1750	460/3/1750	575/3/1750
A1	ROTOR; W/SHAFT – ORDINARY LOCATION	26576D310	26576D310	26576D310	26576D310	26576D310	26576D310
	ROTOR; W/SHAFT – HAZARDOUS LOCATION	26576D310X	26576D310X	26576D310X	26576D310X	26576D310X	26576D310X
A2	HOUSING, BRG; UPPER	23557D010	23557D011	23557D011	23557D010	23557D011	23557D010
A3	HOUSING; & STATOR – HAZARDOUS LOCATION	23558E765	23558E766	23558E766	23558E767	23558E766	23558E767
	HOUSING; & STATOR – ORDINARY LOCATION	23558E365	23558E366	23558E366	23558E367	23558E366	23558E367

MOTOR PARTS

1150 RPM

Item	Description	5 HP 200/3/1150	5 HP 230/3/1150	5 HP 460/3/1150	5 HP 575/3/1150	7.5 HP 200/3/1150
A1	ROTOR; W/SHAFT – ORDINARY LOCATION	26576D303	26576D303	26576D303	26576D303	26576D302
	ROTOR; W/SHAFT – HAZARDOUS LOCATION	26576D303X	26576D303X	26576D303X	26576D303X	26576D302X
A2	HOUSING, BRG; UPPER	23557D010	23557D011	23557D011	23557D010	23557D010
A3	HOUSING; & STATOR – HAZARDOUS LOCATION	23558E774	23558E775	23558E775	23558E776	23558E749
	HOUSING; & STATOR – ORDINARY LOCATION	23558E374	23558E375	23558E375	23558E376	23558E349

Item	Description	7.5 HP 230/3/1150	7.5 HP 460/3/1150	7.5 HP 575/3/1150	10 HP 200/3/1150	10 HP 230/3/1150
A1	ROTOR; W/SHAFT – ORDINARY LOCATION	26576D302	26576D302	26576D302	26576D306	26576D306
	ROTOR; W/SHAFT – HAZARDOUS LOCATION	26576D302X	26576D302X	26576D302X	26576D306X	26576D306X
A2	HOUSING, BRG; UPPER	23557D011	23557D011	23557D010	23557D010	23557D011
A3	HOUSING; & STATOR – HAZARDOUS LOCATION	23558E750	23558E750	23558E751	23558E749	23558E750
	HOUSING; & STATOR – ORDINARY LOCATION	23558E350	23558E350	23558E351	23558E349	23558E350

Item	Description	10 HP 460/3/1150	10 HP 575/3/1150	15 HP 200/3/1150	15 HP 230/3/1150	15 HP 460/3/1150
A1	ROTOR; W/SHAFT – ORDINARY LOCATION	26576D306	26576D306	26576D306	26576D306	26576D306
	ROTOR; W/SHAFT – HAZARDOUS LOCATION	26576D306X	26576D306X	26576D306X	26576D306X	26576D306X
A2	HOUSING, BRG; UPPER	23557D011	23557D010	23557D010	23557D011	23557D011
A3	HOUSING; & STATOR – HAZARDOUS LOCATION	23558E750	23558E751	23558E752	23558E753	23558E753
	HOUSING; & STATOR – ORDINARY LOCATION	23558E350	23558E351	23558E352	23558E353	23558E353

Item	Description	15 HP 575/3/1150	20 HP 200/3/1150	20 HP 230/3/1150	20 HP 460/3/1150	20 HP 575/3/1150
A1	ROTOR; W/SHAFT – ORDINARY LOCATION	26576D306	26576D306	26576D306	26576D306	26576D306
	ROTOR; W/SHAFT – HAZARDOUS LOCATION	26576D306X	26576D306X	26576D306X	26576D306X	26576D306X
A2	HOUSING, BRG; UPPER	23557D010	23557D010	23557D011	23557D011	23557D010
A3	HOUSING; & STATOR – HAZARDOUS LOCATION	23558E754	23558E752	23558E753	23558E753	23558E754
	HOUSING; & STATOR – ORDINARY LOCATION	23558E354	23558E352	23558E353	23558E353	23558E354

870 RPM

Item	Description	2 HP 200/3/870	2 HP 230/3/870	2 HP 460/3/870	2 HP 575/3/870	3 HP 200/3/870	3 HP 230/3/870	3 HP 460/3/870	3 HP 575/3/870
A1	ROTOR; W/SHAFT – ORDINARY LOCATION	26576D300	26576D300	26576D300	26576D300	26576D300	26576D300	26576D300	26576D300
	ROTOR; W/SHAFT – HAZARDOUS LOCATION	26576D300X	26576D300X	26576D300X	26576D300X	26576D300X	26576D300X	26576D300X	26576D300X
A2	HOUSING, BRG; UPPER	23557D010	23557D011	23557D011	23557D010	23557D010	23557D011	23557D011	23557D010
A3	HOUSING; & STATOR – HAZARDOUS LOCATION	23558E743	23558E744	23558E744	23558E745	23558E743	23558E744	23558E744	23558E745
	HOUSING; & STATOR – ORDINARY LOCATION	23558E343	23558E344	23558E344	23558E345	23558E343	23558E344	23558E344	23558E345

Item	Description	5 HP 200/3/870	5 HP 230/3/870	5 HP 460/3/870	5 HP 575/3/870	7.5 HP 200/3/870	7.5 HP 230/3/870	7.5 HP 460/3/870	7.5 HP 575/3/870
A1	ROTOR; W/SHAFT – ORDINARY LOCATION	26576D300	26576D300	26576D300	26576D300	26576D302	26576D302	26576D302	26576D302
	ROTOR; W/SHAFT – HAZARDOUS LOCATION	26576D300X	26576D300X	26576D300X	26576D300X	26576D302X	26576D302X	26576D302X	26576D302X
A2	HOUSING, BRG; UPPER	23557D010	23557D011	23557D011	23557D010	23557D010	23557D011	23557D011	23557D010
A3	HOUSING; & STATOR – HAZARDOUS LOCATION	23558E743	23558E744	23558E744	23558E745	23558E771	23558E772	23558E772	23558E773
	HOUSING; & STATOR – ORDINARY LOCATION	23558E343	23558E344	23558E344	23558E345	23558E371	23558E372	23558E372	23558E373

WET END PARTS

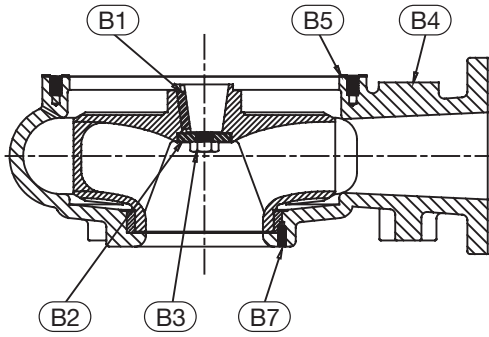

4VC / 4VCX

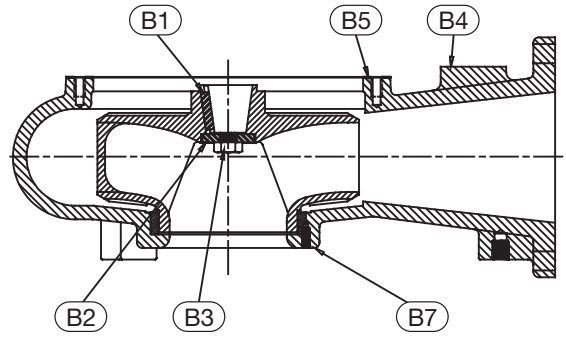

6VC / 6VCX

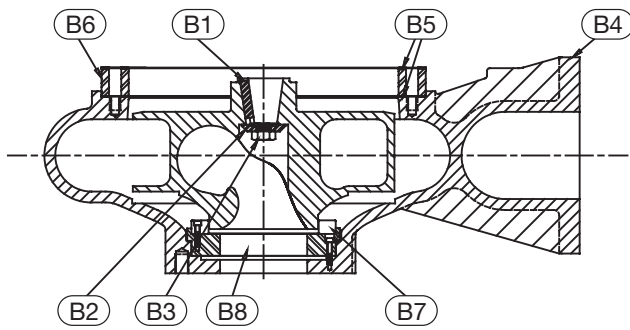

4VE / 4VEX

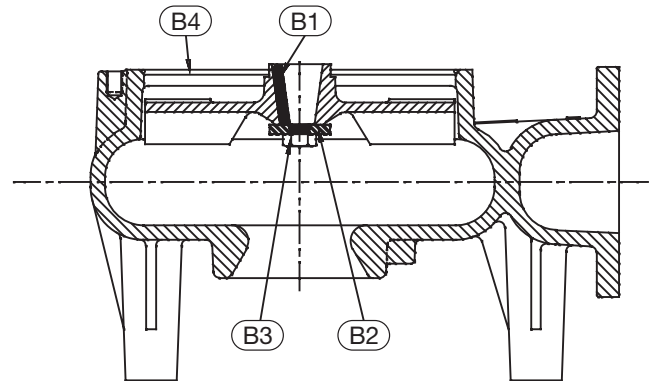

**4RC / 4RCX
1750 RPM and 1150 RPM**

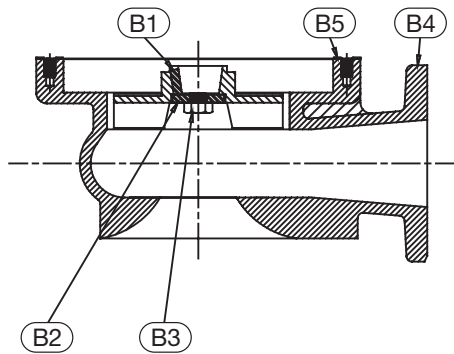

**4RC / 4RCX
3450 RPM**

WET END PARTS LIST

Item	Description	4RC / 4RCX 3450 RPM	4RC / 4RCX 1150 / 1750 RPM	4VC / 4VCX	4VE / 4VEX	6VC / 6VCX
B1	KEY-SQ. SST	05818A087	05818A071	05818A071	05818A071	05818A071
B2	WASHER-RETAINER	23609A004	23609A004	23609A004	23609A004	23609A004
B3	SCREW-CAP HEX SST 1/2	19106A017	19106A017	19106A017	19106A017	19106A017
B4	CASE-VOLUTE	26606E000	107835002	23606F010	26889F000	23606F000
B5	GASKET	05863A021	---	05863A021	05863A021 (2)	05863A021
B6	PLATE-ADAPTER/SPACER	---	---	---	26888D000	---
B7	RING-WEAR	---	---	23607B000	26889F010B	23607B000
B8	ADAPTER-WEAR RING	---	---	---	26889F011C	---

IMPELLER CHART

Pump	RPM	HP	Trim	Impeller
4VC / 4VCX	1750	15	8.5	23608D548
4VC / 4VCX	1750	20	9	23608D544
4VC / 4VCX	1750	25	9.5	23608D540
4VC / 4VCX	1750	30	10	23608D536
4VC / 4VCX	1750	40	11	23608D528
4VC / 4VCX	1750	50	11.5	23608D524
4VC / 4VCX	1750	60	12	23608D520

4VC / 4VCX	1150	5	9	23608D544
4VC / 4VCX	1150	7.5	10	23608D536
4VC / 4VCX	1150	10	10.75	23608D530
4VC / 4VCX	1150	15	11.75	23608D522
4VC / 4VCX	1150	20	12	23608D520

4VC / 4VCX	870	2	8	23608D552
4VC / 4VCX	870	3	9	23608D544
4VC / 4VCX	870	5	11	23608D528
4VC / 4VCX	870	7.5	12	23608D520

4VE / 4VEX	1750	15	9	26899D212
4VE / 4VEX	1750	20	10	26899D208
4VE / 4VEX	1750	25	11	26899D204
4VE / 4VEX	1750	30	12	26899D200

Note: Standard non-overloading impeller diameters shown.

Pump	RPM	HP	Trim	Impeller
6VC / 6VCX	1750	15	8.5	23608D548
6VC / 6VCX	1750	20	9	23608D544
6VC / 6VCX	1750	25	9.5	23608D540
6VC / 6VCX	1750	30	10	23608D536
6VC / 6VCX	1750	40	11	23608D528
6VC / 6VCX	1750	50	11.5	23608D524
6VC / 6VCX	1750	60	12	23608D520

6VC / 6VCX	1150	5	8.5	23608D548
6VC / 6VCX	1150	7.5	9.5	23608D540
6VC / 6VCX	1150	10	10	23608D536
6VC / 6VCX	1150	15	11.5	23608D524
6VC / 6VCX	1150	20	12	23608D520

6VC / 6VCX	870	2	8.5	23608D548
6VC / 6VCX	870	3	9.5	23608D540
6VC / 6VCX	870	5	10.5	23608D532
6VC / 6VCX	870	7.5	12	23608D520

4RC / 4RCX	3450	20	5.5	26605C524
4RC / 4RCX	3450	25	5.75	26605C522
4RC / 4RCX	3450	30	6	26605C520
4RC / 4RCX	3450	40	6.5	26605C516
4RC / 4RCX	3450	50	7	26605C512
4RC / 4RCX	3450	60	7.5	26605C508

4RC / 4RCX	1750	10	7.88	069585112
4RC / 4RCX	1750	15	7.88	069585112
4RC / 4RCX	1750	20	8.63	069585122
4RC / 4RCX	1750	25	9.25	069585132
4RC / 4RCX	1750	30	10.31	069585142
4RC / 4RCX	1750	40	11.5	069585012

4RC / 4RCX	1150	3	7.38	069585252
4RC / 4RCX	1150	5	8.63	069585122
4RC / 4RCX	1150	7.5	10	069585042
4RC / 4RCX	1150	10	11.25	069585192
4RC / 4RCX	1150	15	12	069585002

STANDARD LIMITED WARRANTY

Pentair Myers® warrants its products against defects in material and workmanship for a period of 12 months from the date of shipment from Pentair Myers or 18 months from the manufacturing date, whichever occurs first – provided that such products are used in compliance with the requirements of the Pentair Myers catalog and technical manuals for use in pumping raw sewage, municipal wastewater or similar, abrasive-free, noncorrosive liquids.

During the warranty period and subject to the conditions set forth, Pentair Myers, at its discretion, will repair or replace to the original user, the parts that prove defective in materials and workmanship. Pentair Myers reserves the right to change or improve its products or any portions thereof without being obligated to provide such a change or improvement for prior sold and/or shipped units.

Start-up reports and electrical schematics may be required to support warranty claims. Submit at the time of start-up through the Pentair Myers website: <http://forms.pentairliterature.com/startupform/startupform.asp?type=m>. Warranty is effective only if Pentair Myers authorized control panels are used. All seal fail and heat sensing devices must be hooked up, functional and monitored or this warranty will be void. Pentair Myers will cover only the lower seal and labor thereof for all dual seal pumps. Under no circumstance will Pentair Myers be responsible for the cost of field labor, travel expenses, rented equipment, removal/reinstallation costs or freight expenses to and from the factory or an authorized Pentair Myers service facility.

This limited warranty will not apply: (a) to defects or malfunctions resulting from failure to properly install, operate or maintain the unit in accordance with the printed instructions provided; (b) to failures resulting from abuse, accident or negligence; (c) to normal maintenance services and parts used in connection with such service; (d) to units that are not installed in accordance with applicable local codes, ordinances and good trade practices; (e) if the unit is moved from its original installation location; (f) if unit is used for purposes other than for what it is designed and manufactured; (g) to any unit that has been repaired or altered by anyone other than Pentair Myers or an authorized Pentair Myers service provider; (h) to any unit that has been repaired using non factory specified/OEM parts.

Warranty Exclusions: PENTAIR MYERS MAKES NO EXPRESS OR IMPLIED WARRANTIES THAT EXTEND BEYOND THE DESCRIPTION ON THE FACE HEREOF. PENTAIR MYERS SPECIFICALLY DISCLAIMS THE IMPLIED WARRANTIES OF MERCHANTABILITY AND FITNESS FOR ANY PARTICULAR PURPOSE.

Liability Limitation: IN NO EVENT SHALL PENTAIR MYERS BE LIABLE OR RESPONSIBLE FOR CONSEQUENTIAL, INCIDENTAL OR SPECIAL DAMAGES RESULTING FROM OR RELATED IN ANY MANNER TO ANY PENTAIR MYERS PRODUCT OR PARTS THEREOF. PERSONAL INJURY AND/OR PROPERTY DAMAGE MAY RESULT FROM IMPROPER INSTALLATION. PENTAIR MYERS DISCLAIMS ALL LIABILITY, INCLUDING LIABILITY UNDER THIS WARRANTY, FOR IMPROPER INSTALLATION. PENTAIR MYERS RECOMMENDS INSTALLATION BY PROFESSIONALS.

Some states do not permit some or all of the above warranty limitations or the exclusion or limitation of incidental or consequential damages and therefore such limitations may not apply to you. No warranties or representations at any time made by any representatives of Pentair Myers shall vary or expand the provision hereof.



MYERS®

1101 MYERS PARKWAY
ASHLAND, OHIO, USA 44805
419-289-1144

490 PINEBUSH ROAD, UNIT #4
CAMBRIDGE, ONTARIO, CANADA N1T 0A5
800-363-PUMP

WWW.FEMYERS.COM