

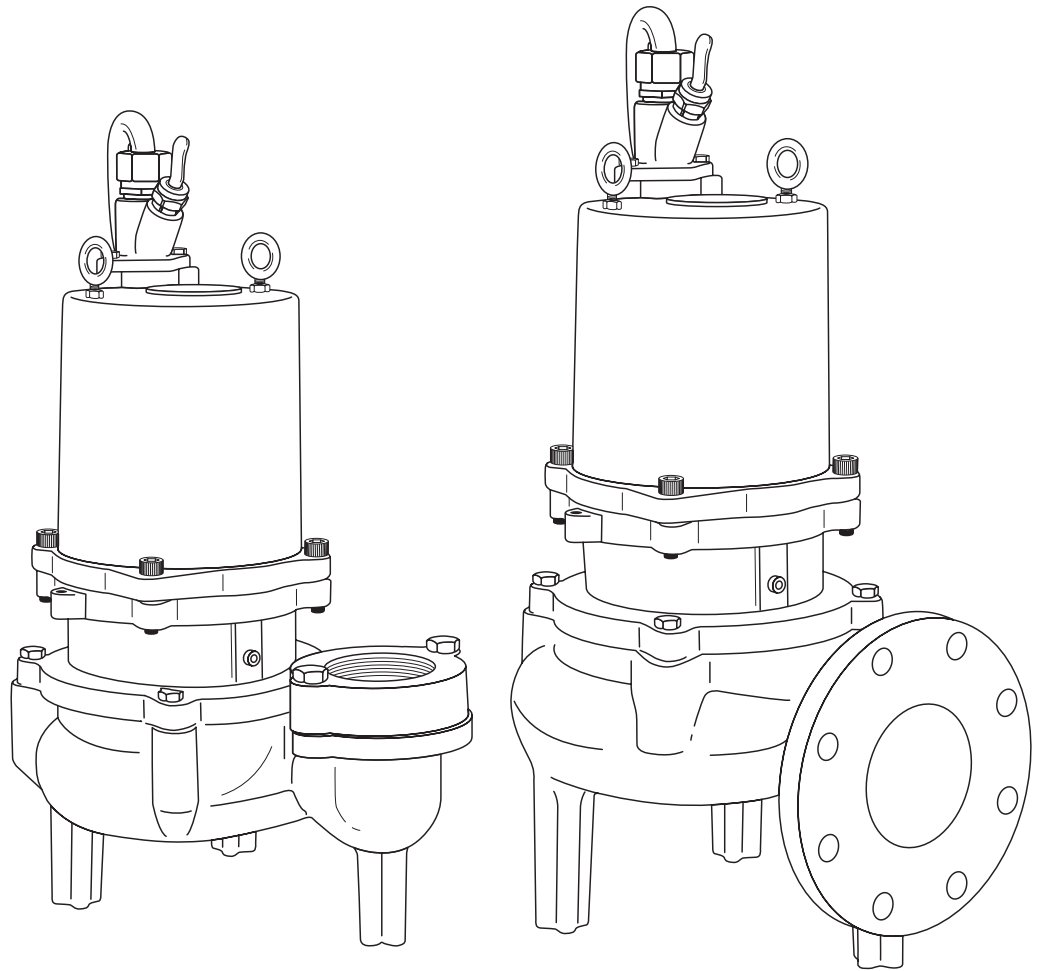

**MYERS®**



# MODELS MS(B)3S(D) and MS(B)4S(D) **SUBMERSIBLE SEWAGE PUMP DUAL SEAL PUMPS**

## **INSTALLATION AND SERVICE MANUAL**



NOTE! To the installer: Please make sure you provide this manual to the owner of the equipment or to the responsible party who maintains the system.

## GENERAL INFORMATION

### Attention:

This manual contains important information for the safe use of this product. Read this manual completely before using this product and refer to it often for continued safe product use. Do not throw away or lose this manual. Keep it in a safe place so that you may refer to it often. Reasonable care and safe methods should be practiced. Check local codes and requirements before installation.

### Unpacking Pump:

Remove pump from carton. When unpacking unit, check for concealed damage. Claims for damage must be made at the receiving end through the delivery carrier. Damage cannot be processed from the factory.

**WARNING:** Before handling these pumps and controls, always disconnect the power first. Do not smoke or use sparkable electrical devices or flames in a septic (gaseous) or possible septic sump.

### CALIFORNIA PROPOSITION 65 WARNING:

**▲ WARNING** This product and related accessories contain chemicals known to the State of California to cause cancer, birth defects or other reproductive harm.

### Pumps Not Operating or in Storage:

Pumps with carbon ceramic seals must have impellers manually rotated (6 revolutions) after setting non-operational for three months or longer and prior to electrical start-up.

### Pump:

This series of submersible pumps is supplied for single and three phase and for 200, 230, 460 or 575 volts. Power cable is supplied with a green wire for ground. Be sure green wire is connected to a ground lug in the control panel, and the control panel must be connected to a ground rod or ground wire from supply service.

**NOTE:** All single phase pumps require properly sized start capacitor, start relay and run capacitor in the panel.

### Sump Level Control:

Sump level is controlled by The float is held in position by a weight attached to the power cord above the float. The cord supports the float and is adjusted for height from the surface.

Typical duplex systems use three floats; the lowest float turns the pumps off, the next higher float starts the lead pump, the next higher float (override) starts the lag pump. The pumps alternate on successive cycles.

Two pumps operate together only if sump level rises to the third or override float. The override float also brings on the second pump in case of failure of the first pump. Extra

floats with appropriate controls can be supplied for alarm functions. Triplex systems use four floats. The fourth highest float brings on the second lag pump. Three pumps operate together only if sump level rises to the fourth float (second override). This float also brings on the third pump in case of failure of either or both of the first two pumps.

### Alarm Controls:

The alarm float is usually set above the override level so the alarm will signal only if the override level is exceeded. However, some engineers prefer to have the alarm float set below the override level as it is possible for one pump to fail and the other pump to operate on the override level with the sump level never reaching the alarm level. This is particularly true in cases of low inflow capacity.

### Electrical Control Panel:

It is recommended that the Myers® control panel be used with all pumps as proper start components and pump protection are furnished.

**NOTE:** All single phase pumps require properly sized start capacitor, start relay and run capacitor in the control panel.

**IMPORTANT:** If Myers control panel is not used and the motor fails because of improper components, the warranty is void.

Myers electrical equipment is installed in a weatherproof enclosure. Electrical equipment includes a main circuit breaker for each pump, a magnetic starter with overload protection for each pump, an H-O-A switch and run light for each pump, an electric alternator and a transformer to provide appropriate control for control circuit and alarms.

### Overload Heaters:

If a Myers control panel is not used, on three phase pumps all three phases must have overload protection. The overload should be ambient compensated class 10. The heaters full load amps on the pump should be sized in accordance with the nameplate amps on the motor housing. The amp draw on these submersible motors is slightly higher than a corresponding horsepower surface motor so heaters must be sized by the nameplate full load amp rating.

Single phase pumps with capacitor start circuit must have the overload protection on the black pump lead.

**NOTE:** On single phase pumps the white, black, and red pump leads must be connected properly for the pump to run.

## PUMP INSTALLATION

### Installing Pump in Sump:

Before installing pump in sump, lay it on side and turn impeller with fingers. Impeller may be slightly stuck due to factory test water so it must be broken loose with small

bar or screwdriver in edge of vanes. The impeller should turn freely.

Clean all trash and sticks from sump and connect pump to piping. A check valve must be installed on each pump. A gate or plug valve in each pump discharge line is also recommended. This valve should be installed on the discharge side of the check valve so if necessary to service the check valve, the line pressure can be cut off. Single pump systems are sometimes installed without a check valve where it is desirable to self-drain the discharge line to prevent freezing. This can be done only with short discharge lines. Otherwise water will return to the sump and cause short cycling of the pump.

#### **NEMA 4 Junction Box (Optional):**

If electrical control panel is to be set remote from the pump sump, a NEMA 4 junction box should be used to make power and control connections. The Myers NEMA 4 junction box is provided with compression connectors for sealing all wires. No sealing compound is needed to make connections waterproof.

The size of any additional wiring from the pump cord to the panel is based on the distance and pump current. Double check that all wiring is properly connected and tight.

NOTE: On single phase pumps the white, black and red pump wires must be connected properly to the panel. Only the proper sequence will work.

#### **Installing Switch Float:**

The float cords are supported by a mounting bracket that is attached to sump wall or cover or to the NEMA 4 junction box.

Cord snubbers are used to hold the cord in place. Float level can be changed at any time by loosening the snubber and readjusting cord length.

In either simplex or duplex system the lower or turn-off float is set just above the top of volute so that the volute will always be submerged during the pumping cycle. The second or lead/on float is set at about 24 inches above the lower turn-off control.

More distance between turn-on and turn-off controls can be used but sewage may become septic and excessive solids may collect for the pump to handle. A frequent pumping cycle is recommended for best operation.

If an alarm system is used, this control is usually set about 6 inches above the override control.

Some engineers as described previously prefer to have the alarm control set below the override control.

#### **Making Electrical Connections:**

All electrical wiring must be in accordance with local code.

IMPORTANT: If equipment is not properly wired and protected as recommended, the warranty is void.

## **PUMP OPERATIONS**

#### **Starting System:**

Turn H-O-A switch to Off position, then turn on main circuit breakers.

Open all discharge valves and allow water to rise in the sump pump.

Turn H-O-A switch to Hand position on one pump and notice operation. If pump is noisy and vibrates, rotation is wrong. To change rotation (three phase), interchange any two line leads to motor. Do not interchange main incoming lines. If duplex system, check second pump in the same manner.

Now set both H-O-A switches to Auto position and allow water to rise in sump until one pump starts. Allow pump to operate until level drops to turn-off point.

Allow sump level to rise to start other pump. Notice run lights on panel; pumps should alternate on each successive cycle of operation.

Turn both H-O-A switches to the Off position and allow sump to fill to the override control level.

Turn both switches to Auto position and both pumps should start and operate together until level drops to turn-off point.

Repeat this operation cycle several times before leaving the job.

Check voltage when pumps are operating and check the amp draw of each pump. On three phase pumps, check amps on each wire as sometimes a high leg will exist. One leg can be somewhat higher (5 to 10%) without causing trouble. For excessive voltage, the power company should be consulted.

## **PUMP SERVICE**

As the motors are oil filled, no lubrication or other maintenance is required. The pump should be lifted once every two years and the oil drained from the motor chamber to check for water.

Generally these pumps give very reliable service and can be expected to operate for years on normal sewage pumping without failure.

#### **Lightning:**

In some areas where considerable lightning occurs, it is recommended that a lightning arrester be installed at the

control panel.

Complete data on lightning arrestors and cost are available from the factory. Lightning arrestors are good insurance against damage to an expensive motor.

**WARNING:** Before handling these pumps and controls, always disconnect the power first.

Do not smoke or use sparkable electrical devices or flames in a septic (gaseous) or possible septic sump.

### **Field Service on Motor:**

All submersible motors can be serviced (out of warranty) in the field by any reliable motor service shop. Any pump (in warranty) must be returned to the factory for service or repaired at an authorized Myers service center. Charges will not be allowed if (in warranty) pump is not taken to an authorized Myers service center.

When field service is performed on a pump, these instructions should be carefully followed.

### **Replacing Stator:**

If stator only is damaged, it may not be necessary to completely dismantle pump as stator and housing can be lifted from pump without disturbing seals or bearings.

Drain all oil from upper housing. If oil is clean and no water is present, seals can be considered satisfactory to reuse.

After chamber is drained, remove hold-down bolts and lift off motor housing. Use care in lifting.

Set assembly on bench and remove cord cap assembly by removing bolts. When this is lifted off, connection wires to motor will be exposed. These wires will probably be burned, but each wire is tagged with a metal marker giving wire number. Cut the wires.

If the leads to the cord cap assembly are burned, the cord cap assembly must be replaced.

After stator retaining ring is removed, turn housing upright and bump on hardwood blocks. This should jar the stator loose and allow it to drop out.

Thoroughly clean housing before replacing new stator. Replace stator and make all wire connections to cord cap assembly before replacing housing on pump. This is important as leads must be tucked behind the windings by using hands up through rotor core.

**IMPORTANT:** Use only compression type insulated connectors on the wires. Do not tape leads as oil will deteriorate the tape and cause damage to stator and bearings.

Check top bearing. If clean and does not turn rough, bearings can be reused and it is not necessary to completely dismantle pump to change bearings. If bearings are damaged with dirt or heat, they must be replaced.

Replace motor housing onto seal chamber and bolt in place with capscrews.

Be sure O-ring seal has been replaced. If O-ring is nicked or cut, replace with new O-ring. This applies to all O-rings used in assembly.

After all leads are reconnected, make a high voltage ground test on each wire. The only wire that should show ground is the green power lead.

Refill motor chamber with oil. Use only high grade transformer oil or regular Myers special submersible oil. Fill chamber until oil covers top of windings. Leave air space in top for expansion. Use Permatex® on plug threads.

### **Replacing Seals and Bearings:**

Drain all oil from motor chamber as described.

Remove bolts that hold motor housing to bearing housing. Remove screws holding bearing housing to volute housing.

Lift rotating assembly (rotor, shaft and impeller) from pump case and place horizontally on bench. With hardwood block, tap end of impeller to loosen from shaft.

Remove lower seal spring and pry out seal with screwdriver.

Remove screws holding seal plate to bearing housing, then remove snap ring that retains the upper seal and pry out seal with screwdriver.

Use bearing puller to remove bearings. Replace with new bearings. Press only on inner face of bearing when replacing. Pressing on outer face can damage the bearing.

**IMPORTANT:** Do not use any of the old seal parts. Replace with all new seals.

Thoroughly clean all castings before replacing seals. One grain of dirt between the seal faces can cause failure. Examine all O-rings for nicks before reusing.

Use Loctite® on socket head locking screw in end of shaft.

Before refilling chamber with oil, air test as described above.

Refill chamber with oil.

Always check all leads with high voltage or with Megger for grounds before operating the pump.

## PUMP TROUBLESHOOTING

Below is a list of common problems and the probable causes:

### Pump will not start:

No power to the motor. Check for blown fuse or tripped circuit.

Hand-Off-Auto switch may be in the Off position.

Control circuit transformer fuse may be blown.

Overload relay on starter may be tripped. Push to reset.

### Pump will not start and overload heaters trip:

Turn off power and check motor leads with Megger or ohmmeter for possible ground.

Check resistance of motor windings. All three phases should show close to the same reading.

If no grounds exist and the motor windings check OK, remove pump from sump and check for clogged or blocked impeller.

### Pump operates with selector switch in Hand position but will not operate in Auto position:

This indicates trouble in the float level control or the alternator relay.

To check for defective float control, put selector switch in Auto position and turn off main power. Put a jumper wire on terminal strip. Turn on power and if pump starts, trouble is in float control. Replace control.

### Pump runs but will not shut off:

The pump may be air locked. Turn pump off and let set for several minutes, then restart.

The lower float control may be hung-up in the closed position. Check in sump to be sure control is free.

Selector switch may be in the Hand position.

### Pump does not deliver proper capacity:

Discharge gate valve may be partially closed or partially clogged.

Check valve may be partially clogged. Raise level up and down to clear.

Pump may be running in wrong direction. Low speed pumps can operate in reverse direction without much noise or vibration.

Discharge head may be too high. Check total head with gauge when pump is operating. Total head is discharge gauge pressure converted to feet plus vertical height from water level in sump to center line of pressure gauge installed in discharge line. Gauge should be installed on pump side of all valves. Multiply gauge pressure in pounds by 2.31 to get head in feet.

If pump has been in service for some time and capacity falls off, remove pump and check for wear or clogged impeller.

## PUMP WIRING

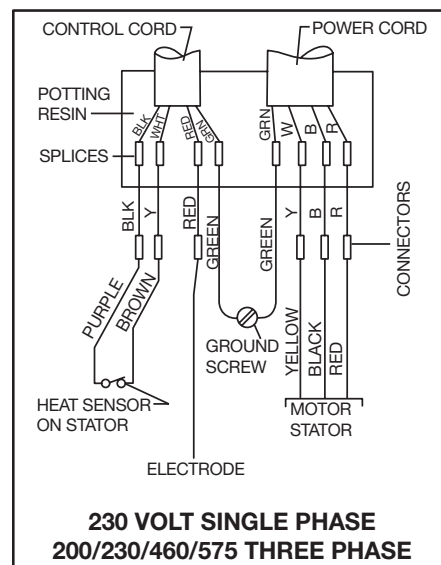

# MS3S/MSB3S Parts List

Item	Eng. No.	Part Description	Qty.
1	12672A001	Wire Connector (all 1φ & 200/575V, 3φ)	3
	002820011	Wire Connector (230/460V, 3φ)	6
2	054540011	Roll Pin	1
3	133910002	Motor Housing	1
4	007360011	Spacer Ring (2 hp 1φ)	1
	007360001	Spacer Ring (2 hp 3φ)	1
5	000640031	Load Spring	1
6	000650211	Upper Bearing	1
7	000650271	Lower Bearing	1
8	003000001	Shaft Seal	S 1
	006960001	Shaft Seal (Carbide) Opt	C 1
9	008340151	O-ring	SC 1
10	011300031	Machine Screw (Flat Head)	4
11	099470002	Volute Case for S3S (shown)	1
	099471002	Volute Case for SB3S	1
12	100120001	Impeller Washer	1
13	19101A003	Impeller Capscrew	1
14	101020011	Key	1
15	099520022	Seal Plate	1
16	001500211	O-ring	SC 1
17	152710335	35' Cord Assembly 14-4	1
	152710305	35' Cord Assembly 12-4	1
	152710315	35' Cord Assembly 10-4	1
18	009950081	Lockwasher	4
19	002990021	Stator Retaining Ring	1
20	099270082	Impeller – 5.25"	1
	099270092	Impeller – 5.69"	1
	099270162	Impeller – 6.06"	1
21	007400195	Rotor w/Shaft (2 hp 1φ)	1
	077730185	Rotor w/Shaft (2 hp 3φ)	1
	013290245	Rotor w/Shaft (3 hp 1φ)	1
	013290245	Rotor w/Shaft (3 hp 3φ)	1
22	24407C215	Stator (2 hp 1φ 230V)	1
	24407C217	Stator (2 hp 3φ 230/460V)	1
	24407C216	Stator (2 hp 3φ 200V)	1
	24407C218	Stator (2 hp 3φ 575V)	1
	24407C200	Stator (3 hp 1φ 230V)	1
	24407C202	Stator (3 hp 3φ 230/460V)	1
	24407C201	Stator (3 hp 3φ 200V)	1
	24407C203	Stator (3 hp 3φ 575V)	1
	517000607	Seal Kit	
	517003607	Carbide Seal Kit	
	003560002	Discharge Flange	1

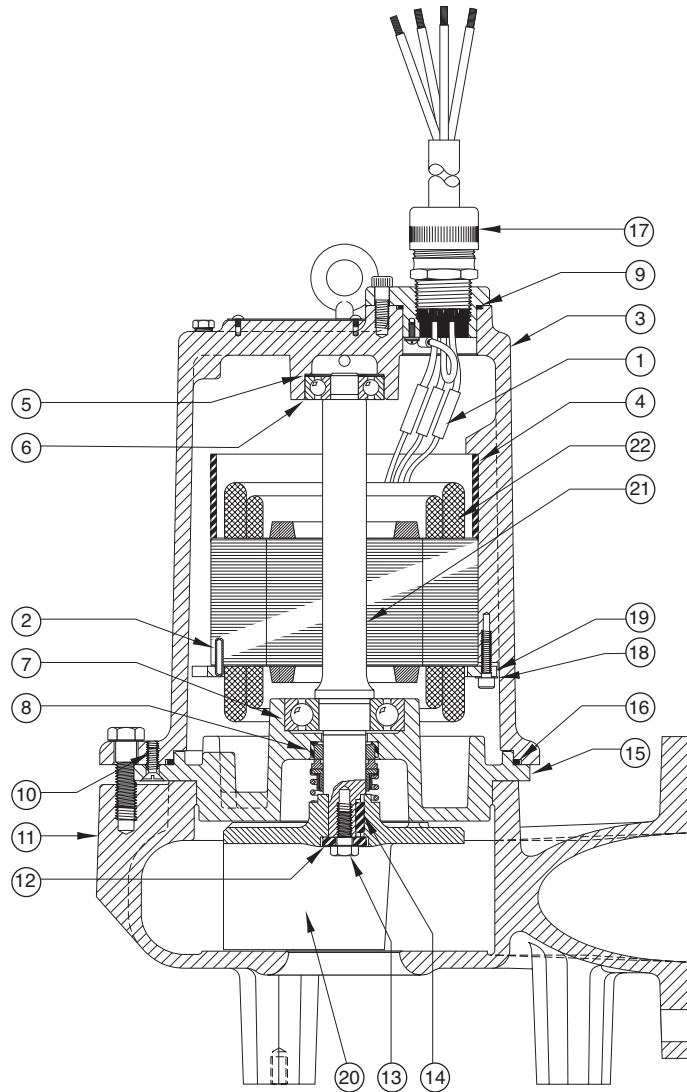

Notes: S — Parts in Seal Kit C — Parts in Carbide Seal Kit — Fill Oil to above Motor Windings

# MS4S/MSB4S Parts List

Item	Eng. No.	Part Description	Qty.
1	24407C200	Stator (3 hp, 1 $\phi$ , 230V)	1
	24407C202	Stator (3 hp, 3 $\phi$ , 230/460V)	1
	24407C201	Stator (3 hp, 3 $\phi$ , 200V)	1
	24407C203	Stator (3 hp, 3 $\phi$ , 575V)	1
	24407C204	Stator (5 hp, 1 $\phi$ , 230V)	1
	24407C206	Stator (5 hp, 3 $\phi$ , 230/460V)	1
	24407C205	Stator (5 hp, 3 $\phi$ , 200V)	1
	24407C207	Stator (5 hp, 3 $\phi$ , 575V)	1
	24407C209	Stator (7-1/2 hp, 3 $\phi$ , 200/230/460V)	1
	24407C210	Stator (7-1/2 hp, 3 $\phi$ , 575V)	1
2	025770001	Wire Connector	As Req.
	12672A001	Wire Connector (14 & 16 wire size)	As Req.
	010060011	Wire Connector (10 & 12 wire size)	As Req.
3	152710335	35' Cord Assembly 14-4	1
	152710305	35' Cord Assembly 12-4	1
	152710315	35' Cord Assembly 10-4	1
	152710325	35' Cord Assembly 8-4 S00W	1
	152710345	35' Cord Assembly 8-4 W	1
4	099780072	Impeller - 6.06"	1
	099780082	Impeller - 6.75"	1
	099780092	Impeller - 7.38"	1
5	000640031	Load Spring	1
6	000650211	Upper Bearing	1
7	000650181	Lower Bearing	1
8	049160001	Shaft Seal	S 1
	049160011	Shaft Seal (Carbide) Opt.	C 1
9	003560042	Discharge Flange	1
10	011300031	Machine Screw (Flat Head)	4
11	099950002	Volute Case for S4S	1
	099951002	Volute Case for SB4S (shown)	1
12	101080001	Impeller Washer	1
13	19101A003	Impeller Capscrew	1
14	089080021	Key	1
15	099960022	Seal Plate	1
16	001500211	O-ring	SC 1
17	010540001	Gasket	1
18	009950081	Lockwasher	4
19	002990021	Stator Retaining Ring	1
20	054540011	Roll Pin	1
21	133910002	Motor Housing	1
22	008340151	O-ring	SC 1
23	013290255	Rotor w/Shaft (3 hp 1 $\phi$ )	1
	013290255	Rotor w/Shaft (All 3 $\phi$ )	1
	013290255	Rotor w/Shaft (5 hp 1 $\phi$ )	1
-	517000617	Seal Kit	
-	517003617	Carbide Seal Kit	

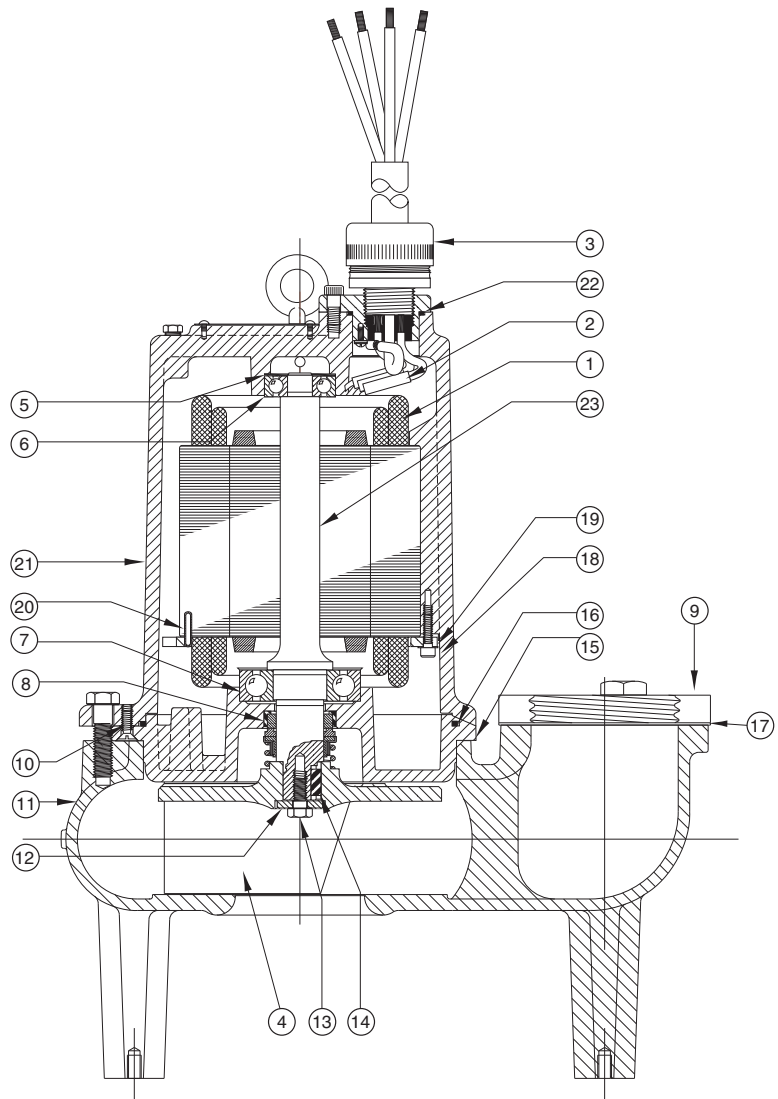

Notes: S — Parts in Seal Kit C — Parts in Carbide Seal Kit — Fill Oil to above Motor Windings

# MS3SD Parts List For use with product built with Regal Beloit/Marathon® motor.

Item	Eng. No.	Part Description	Qty.
1	152720335	35' Cord Assembly 14-4	1
	152720305	35' Cord Assembly 12-4	1
	152720315	35' Cord Assembly 10-4	1
2	008340151	O-ring	1
3	000640031	Spring – Brg.	1
4	000650211	Brg.	1
5	077730175	Rotor/Shaft 2 hp – 230–460/3/60, 1750 rpm	1
	013290265	Rotor/Shaft 3 hp – 230/1-575/3-200/3, 1750 rpm	1
	007400205	Rotor/Shaft 2 hp – 230/1/60, 1750 rpm	1
	077740175	Rotor/Shaft 1 hp –all 1-Phase, 1150 rpm	1
	077730175	Rotor/Shaft 1 hp – all 3-Phase, 1150 rpm	1
6	007360031	Spacer 2 hp, 1750 rpm – 3φ	1
	007360011	Spacer 1 hp, 1150 rpm – 1φ	1
	007360031	Spacer 1 hp, 1150 rpm – 3φ	1
7	060000141	Seal Fail Wire	1
8	24407C215	Stator – 2 hp – 230/1/60 1750 rpm	1
	24407C216	Stator – 2 hp – 200/3/60 1750 rpm	1
	24407C217	Stator – 2 hp – 230,460/3/60 1750 rpm	1
	24407C218	Stator – 2 hp – 575/3/60 1750 rpm	1
	24407C200	Stator – 3 hp – 230/1/60 1750 rpm	1
	24407C201	Stator – 3 hp – 200/3/60 1750 rpm	1
	24407C217	Stator – 3 hp – 230,460/3/60 1750 rpm	1
	24407C203	Stator – 3 hp – 575/3/60 1750 rpm	1
	24407C223	Stator – 1 hp – 230/1/60 1150 rpm	1
	147152031	Stator – 1 hp – 200/1/60 1150 rpm	1
	24407C225	Stator – 1 hp – 230,460/3/60 1150 rpm	1
	24407C224	Stator – 1 hp – 200/3/60 1150 rpm	1
	24407C226	Stator – 1 hp – 575/3/60 1150 rpm	1
9	054540011	Pin – Roll	1
10	000650181	Brg.	1
11	001500571	O-ring	1
12	084720015	Seal Fail	1
13	049160001	Mechanical Seal, Upper (CE-B)*	1
14	049160001	Mechanical Seal, Lower (CE-B)*	1
	049160011	Mechanical Seal, Lower (TC-B)*	1
	049160041	Mechanical Seal, Lower (TC-V)*	1
15	025770001	Wire Connector all	1
16	001500291	O-ring	1
17	099470012	Volute	1
18	009750121	Snap Ring	1
19	089080021	Key Square	1
20	101080001	Washer – Impeller	1
21	12672A001	Wire Connector – all hp 230/1/60 1750 rpm	3
		Wire Connector – all hp, 200,575/3/60, 1750 rpm	3
		Wire Connector – all hp, 230,460/3/60, 1750 rpm	4,6
		Wire Connector – all 1φ, 1150 rpm	3
		Wire Connector – 2 hp, 200,575/3/60, 1150 rpm	3
		Wire Connector – 2 hp, 230,460/3/60, 1150 rpm	4,6
22	099271232	Impeller – 5.25"	1
	099271242	Impeller – 5.69"	1
	099271252	Impeller – 6.13"	1
23	045800011	Screw – Drive	2
24	079900022	Plate – Seal	1
25	001500191	O-ring	1
26	002940032	Housing – Motor	1
27	082060001	Inst Plate	1
28	071450002	Housing – Bearing	1
29	002990021	Ring-Retainer Stator	1
	517001257	Ceramic Seal Kit	
	517001267	Carbide Seal Kit	

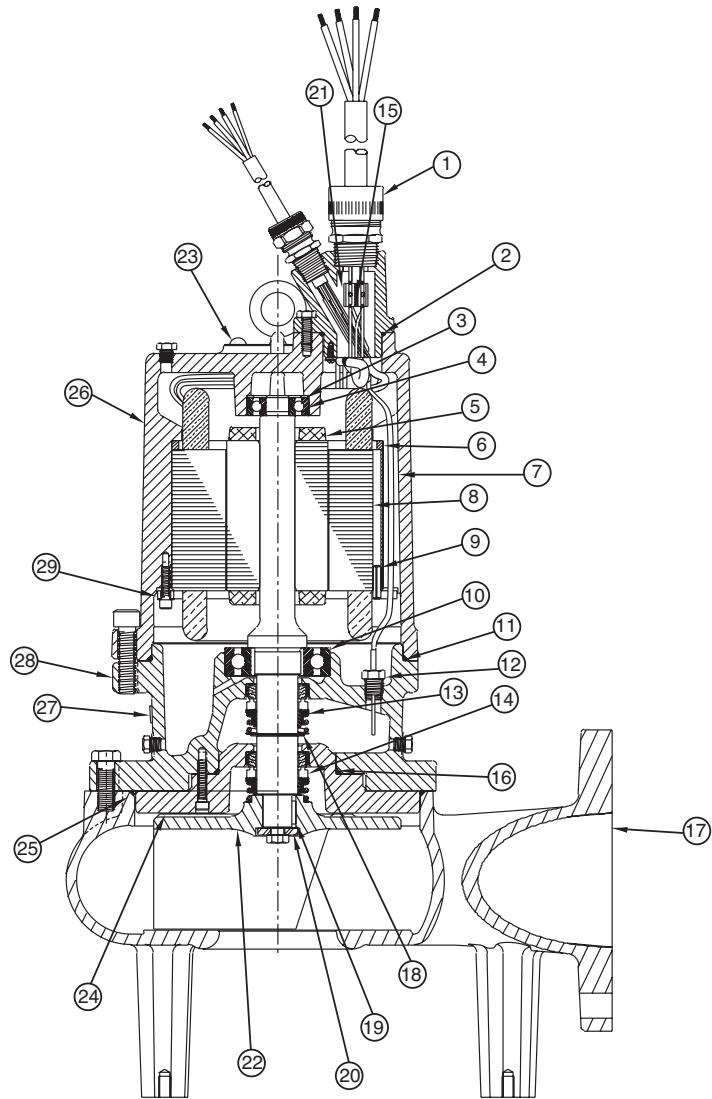

\*— CE-B Carbon Ceramic / Buna-N, TC-B Tungsten Carbide / Buna-N, TC-V Tungsten Carbide / Viton®



# MSB3SD Parts List For use with product built with Regal Beloit/Marathon motor.

Item	Eng. No.	Part Description	Qty.
1	152720335	35' Cord Assembly 14-4	1
	152720305	35' Cord Assembly 12-4	1
	152720315	35' Cord Assembly 10-4	1
2	008340151	O-ring	1
3	000640031	Spring – Brg.	1
4	000650211	Brg.	1
5	013290265	Rotor/Shaft 3 hp – 230-460/3/60	1
	013290265	Rotor/Shaft 3 hp – 230/1-575/3-200/3	1
	007400205	Rotor/Shaft 2 hp – 230/1/60	1
	077730175	Rotor/Shaft 2 hp – all 3φ	1
	077740175	Rotor/Shaft 1 hp – all 1φ	1
	077730175	Rotor/Shaft 1 hp – all 3φ	1
6	007360031	Spacer 2 hp, 1750 RPM – 3φ	1
	007360011	Spacer 1 hp, 1150 RPM – 1φ	1
	007360031	Spacer 1 hp, 1150 RPM – 3φ	1
7	060000141	Seal Fail Wire	1
8	24407C215	Stator – 2 hp – 230/1/60, 1750 rpm	1
	24407C216	Stator – 2 hp – 200/3/60, 1750 rpm	1
	24407C217	Stator – 2 hp – 230,460/3/60, 1750 rpm	1
	24407C218	Stator – 2 hp – 575/3/60, 1750 rpm	1
	24407C200	Stator – 3 hp – 230/1/60, 1750 rpm	1
	24407C201	Stator – 3 hp – 200/3/60, 1750 rpm	1
	24407C217	Stator – 3 hp – 230,460/3/60, 1750 rpm	1
	24407C203	Stator – 3 hp – 575/3/60, 1750 rpm	1
	24407C223	Stator – 1 hp – 230/1/60, 1150 rpm	1
	147152031	Stator – 1 hp – 200/1/60, 1150 rpm	1
	24407C225	Stator – 1 hp – 230,460/3/60, 1150 rpm	1
	24407C224	Stator – 1 hp – 200/3/60, 1150 rpm	1
	24407C226	Stator – 1 hp – 575/3/60, 1150 rpm	1
	9	054540011	Pin – Roll
10	000650181	Brg.	1
11	001500571	O-ring	1
12	084720015	Seal Fail	1
13	049160001	Mechanical Seal, Upper (CE-B)*	1
14	049160001	Mechanical Seal, Lower (CE-B)*	1
	049160011	Mechanical Seal, Lower (TC-B)*	1
14	049160041	Mechanical Seal, Lower (TC-V)*	1
	049160041	Mechanical Seal, Lower (TC-V)*	1
15	010540001	Gasket	1
16	001500291	O-ring	1
17	099471012	Volute	1
18	009750121	Snap Ring	1
19	089080021	Key Square	1
20	101080001	Washer – Impeller	1
21	19105A044	Screw – Hex	2
	099271232	Impeller – 5.25"	1
	099271242	Impeller – 5.69"	1
21	099271252	Impeller – 6.13"	1
	099271252	Impeller – 6.13"	1
23	003560002	Discharge Flange	1
24	079900022	Plate – Seal	1
25	001500191	O-ring	1
26	05454A023	Lock Washer	4
27	12672A001	Wire Connector – all hp 230/1/60 1750 rpm	3
	12672A001	Wire Connector – all hp – 200,575/3/60, 1750 rpm	3
	12672A001	Wire Connector – all hp – 230,460/3/60, 1750 rpm	4,6
	12672A001	Wire Connector – all 1φ, 1150 rpm	3
	12672A001	Wire Connector – 2 hp – 200,575/3/60, 1150 rpm	3
	12672A001	Wire Connector – 2 hp – 230,460/3/60, 1150 rpm	4,6
28	071450002	Housing – Bearing	1
29	010320021	Hex Nut	2
30	002990021	Ring-Retainer Stator	1
31	002940032	Housing – Motor	1
32	025770001	Wire Connector all	1
	517001257	Ceramic Seal Kit	
	517001267	Carbide Seal Kit	

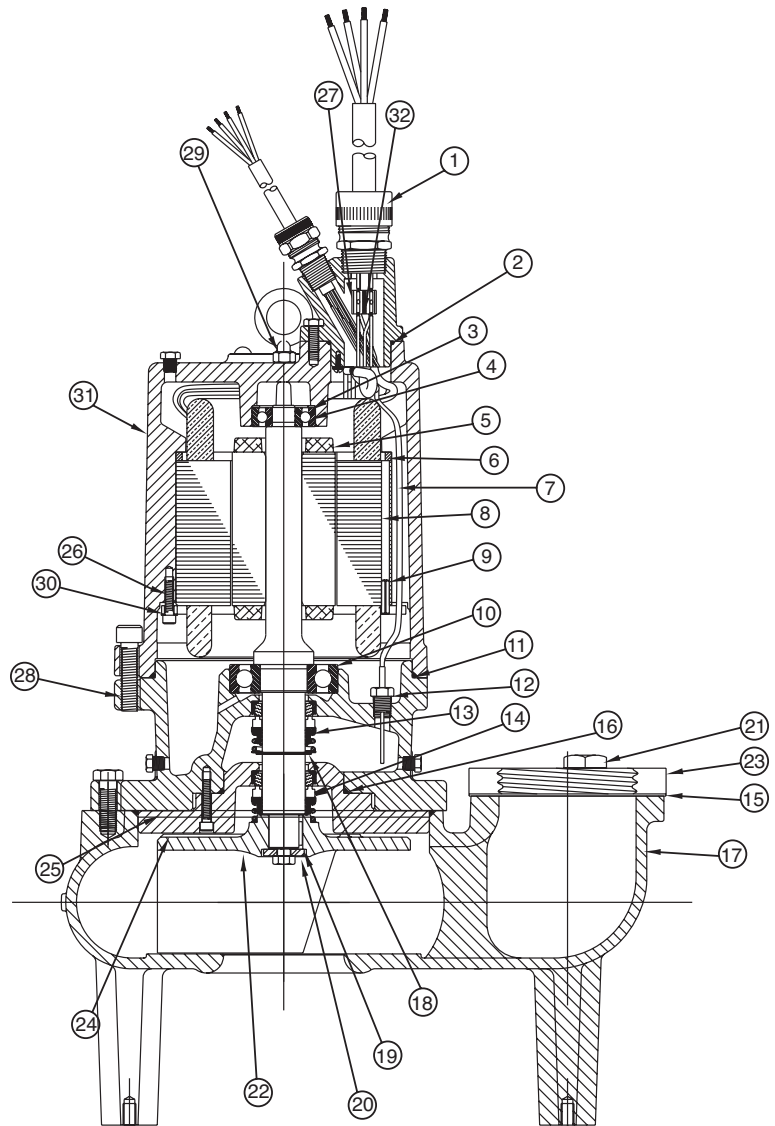

\*— CE-B Carbon Ceramic / Buna-N, TC-B Tungsten Carbide / Buna-N, TC-V Tungsten Carbide / Viton®

# MS4SD Parts List For use with product built with Regal Beloit/Marathon motor.

Item	Eng. No.	Part Description	Qty.
1	152720335	35' Cord Assembly 14-4	1
	152720305	35' Cord Assembly 12-4	1
	152720315	35' Cord Assembly 10-4	1
	152720325	35' Cord Assembly 8-4 S00W	1
	152720345	35' Cord Assembly 8-4 W	1
2	008340151	O-ring	1
3	000640031	Spring – Brg.	1
4	000650211	Brg.	1
5	013290265	Rotor/Shaft 3, 5, & 7.5 hp – all 1750 rpm	1
	013290265	Rotor/Shaft 2 hp – 200,230/1/60, 1150 rpm	1
	007400205	Rotor/Shaft 2 hp – all 3φ, 1150 rpm	1
6	007360001	Spacer 2 hp, 1750 RPM – 3φ	1
7	060000141	Seal Fail Wire	1
8	24407C200	Stator – 3 hp – 230/1/60, 1750 rpm	1
	24407C201	Stator – 3 hp – 200/3/60, 1750 rpm	1
	24407C202	Stator – 3 hp – 230,460/3/60, 1750 rpm	1
	24407C203	Stator – 3 hp – 575/3/60, 1750 rpm	1
	24407C204	Stator – 5 hp – 230/1/60, 1750 rpm	1
	22407C205	Stator – 5 hp – 200/3/60, 1750 rpm	1
	24407C206	Stator – 5 hp – 230,460/3/60, 1750 rpm	1
	24407C207	Stator – 5 hp – 575/3/60, 1750 rpm	1
	24407C209	Stator – 7.5 hp – 200/230/460/3/60, 1750 rpm	1
	24407C210	Stator – 7.5 hp – 575/3/60	1
	24407C231	Stator – 2 hp – 230/1/60, 1150 rpm	1
	147172031	Stator – 2 hp – 200/1/60, 1150 rpm	1
	24407C233	Stator – 2 hp – 230,460/3/60, 1150 rpm	1
24407C232	Stator – 2 hp – 200/3/60, 1150 rpm	1	
24407C234	Stator – 2 hp – 575/3/60, 1150 rpm	1	
9	054540011	Pin – Roll	1
10	000650181	Brg.	1
11	001500571	O-ring	1
12	084720015	Seal Fail	1
13	049160001	Mechanical Seal, Upper (CE-B)*	1
14	049160001	Mechanical Seal, Lower (CE-B)*	1
	049160011	Mechanical Seal, Lower (TC-B)*	1
	049160041	Mechanical Seal, Lower (TC-V)*	1
15	025770001	Wire Connector all	1
16	001500291	O-ring	1
17	099950012	Volute	1
18	009750121	Snap Ring	1
19	089080021	Key Square	1
20	101080001	Washer – Impeller	1
21	12672A001	Wire Connector 2 & 3 hp – 230/1/60, 1750 rpm	3
		Wire Connector 2 & 3 hp – 200,575/3/60, 1750 rpm	3
		Wire Connector 2 & 3 hp – 230,460/3/60, 1750 rpm	4,6
		Wire Connector 5 hp – 230/460/3/60, 1750 rpm	1,3
		Wire Connector 7.5 hp – 230,460,575V, 1750 rpm	3
		Wire Connector all 1φ, 1150 rpm	3
		Wire Connector 2 hp – 200,575/3/60, 1150 rpm	3
	Wire Connector 2 hp – 230,460/3/60, 1150 rpm	4,6	
22	099781312	Impeller – 6.75"	1
	099781302	Impeller – 6.06"	1
	099781292	Impeller – 7.56"	1
23	002940032	Housing – Motor	1
24	079900032	Plate – Seal	1
25	001500231	O-ring	1
26	002990021	Ring – Retainer Stator	1
27	071450002	Housing – Bearing	1
	517001257	Ceramic Seal Kit	
	517001267	Carbide Seal Kit	

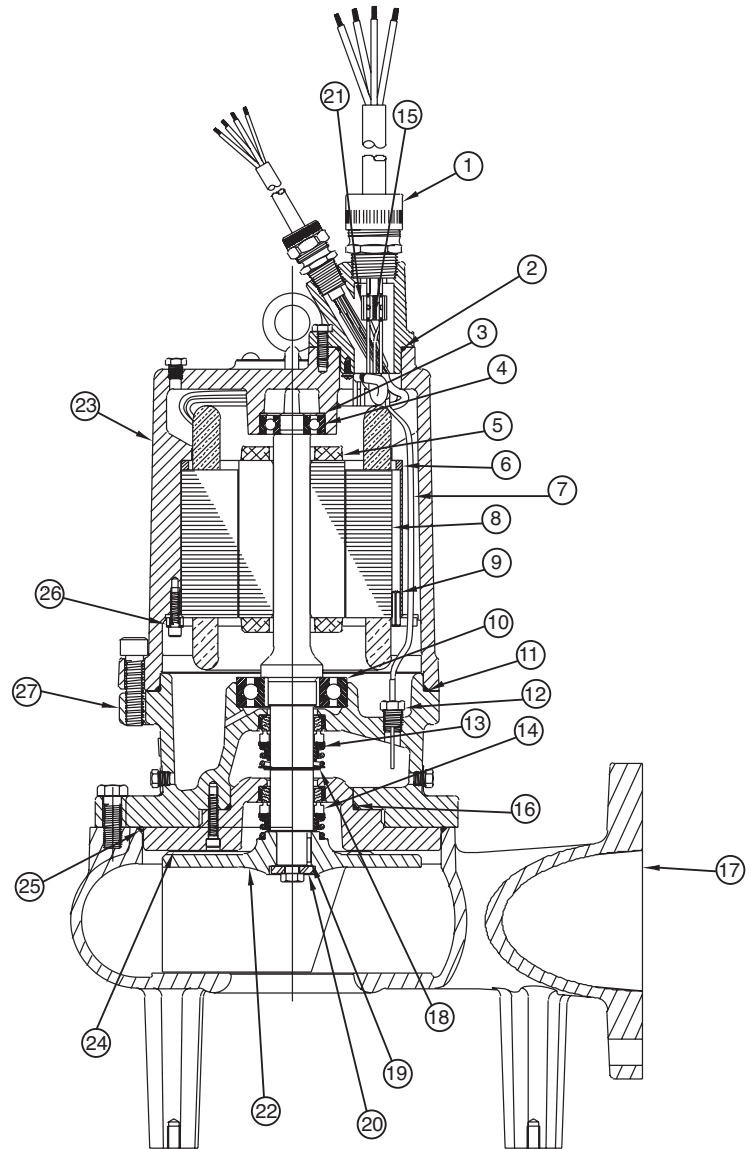

\*— CE-B Carbon Ceramic / Buna-N, TC-B Tungsten Carbide / Buna-N, TC-V Tungsten Carbide / Viton®

# MSB4SD Parts List For use with product built with Regal Beloit/Marathon motor.

Item	Eng. No.	Part Description	Qty.
1	152720335	35' Cord Assembly 14-4	1
	152720305	35' Cord Assembly 12-4	1
	152720315	35' Cord Assembly 10-4	1
	152720325	35' Cord Assembly 8-4 S00W	1
	152720345	35' Cord Assembly 8-4 W	1
2	008340151	O-ring	1
3	000640031	Spring - Brg.	1
4	000650211	Brg.	1
5	013290265	Rotor/Shaft 3,5, & 7.5 hp - all 3φ	1
	013290265	Rotor/Shaft 3 hp - 230/1/60	1
	013290265	Rotor/Shaft 5 hp - 230/1/60	1
	013290265	Rotor/Shaft 2 hp - 200,230/1/60	1
	007400205	Rotor/Shaft 2 hp - all 3φ	1
6	007360001	Spacer 2 hp - 1750 rpm - 3φ	1
7	060000141	Seal Fail Wire	1
8	24407C200	Stator - 3 hp - 230/1/60, 1750 rpm	1
	24407C201	Stator - 3 hp - 200/3/60, 1750 rpm	1
	24407C202	Stator - 3 hp - 230,460/3/60, 1750 rpm	1
	24407C203	Stator - 3 hp - 575/3/60, 1750 rpm	1
	24407C204	Stator - 5 hp - 230/1/60, 1750 rpm	1
	22407C205	Stator - 5 hp - 200/3/60, 1750 rpm	1
	24407C206	Stator - 5 hp - 230,460/3/60, 1750 rpm	1
	24407C207	Stator - 5 hp - 575/3/60, 1750 rpm	1
	24407C209	Stator - 7.5 hp - 200/230/460/3/60, 1750 rpm	1
	24407C210	Stator - 7.5 hp - 575/3/60	1
	24407C231	Stator - 2 hp - 230/1/60, 1150 rpm	1
	147172031	Stator - 2 hp - 200/1/60, 1150 rpm	1
	24407C233	Stator - 2 hp - 230,460/3/60, 1150 rpm	1
	24407C232	Stator - 2 hp - 200/3/60, 1150 rpm	1
24407C234	Stator - 2 hp - 575/3/60, 1150 rpm	1	
9	054540011	Pin - Roll	1
10	000650181	Brg.	1
11	001500571	O-ring	1
12	084720015	Seal Fail	1
13	049160001	Mechanical Seal, Upper (CE-B)*	1
14	049160001	Mechanical Seal, Lower (CE-B)*	1
14	049160011	Mechanical Seal, Lower (TC-B)*	1
	049160041	Mechanical Seal, Lower (TC-V)*	1
15	010540001	Gasket	1
16	001500291	O-ring	1
17	099951012	Volute	1
18	009750121	Snap Ring	1
19	089080021	Key Square	1
20	101080001	Washer - Impeller	1
21	003560042	Discharge Flange	1
	099781312	Impeller - 6.75"	1
	099781302	Impeller - 6.06"	1
22	099781292	Impeller - 7.56"	1
	05454A023	Lock Washer	4
	079900032	Plate - Seal	1
24	001500231	O-ring	1
25	010320021	Hex Nut	2
27	12672A001	Wire Connector - 2 & 3 hp, 230/1/60, 1750 rpm	3
		Wire Connector - 2 & 3 hp, 200,575/3/60, 1750 rpm	3
		Wire Connector - 2 & 3 hp, 230,460/3/60, 1750 rpm	4,6
		Wire Connector - 5 hp, 230,460/3/60, 1750 rpm	1,3
		Wire Connector - 7.5 hp, 230,460,575V, 1750 rpm	3
		Wire Connector - all 1φ 1150 rpm	3
		Wire Connector - 2 hp, 200,575/3/60, 1150 rpm	3
		Wire Connector - 2 hp, 230,460/3/60, 1150 rpm	4,6
28	071450002	Housing - Bearing	1
29	025770001	Wire Connector all	1
30	002990021	Ring - Retainer Stator	1
31	002940032	Housing - Motor	1
-	517001257	Ceramic Seal Kit	
-	517001267	Carbide Seal Kit	

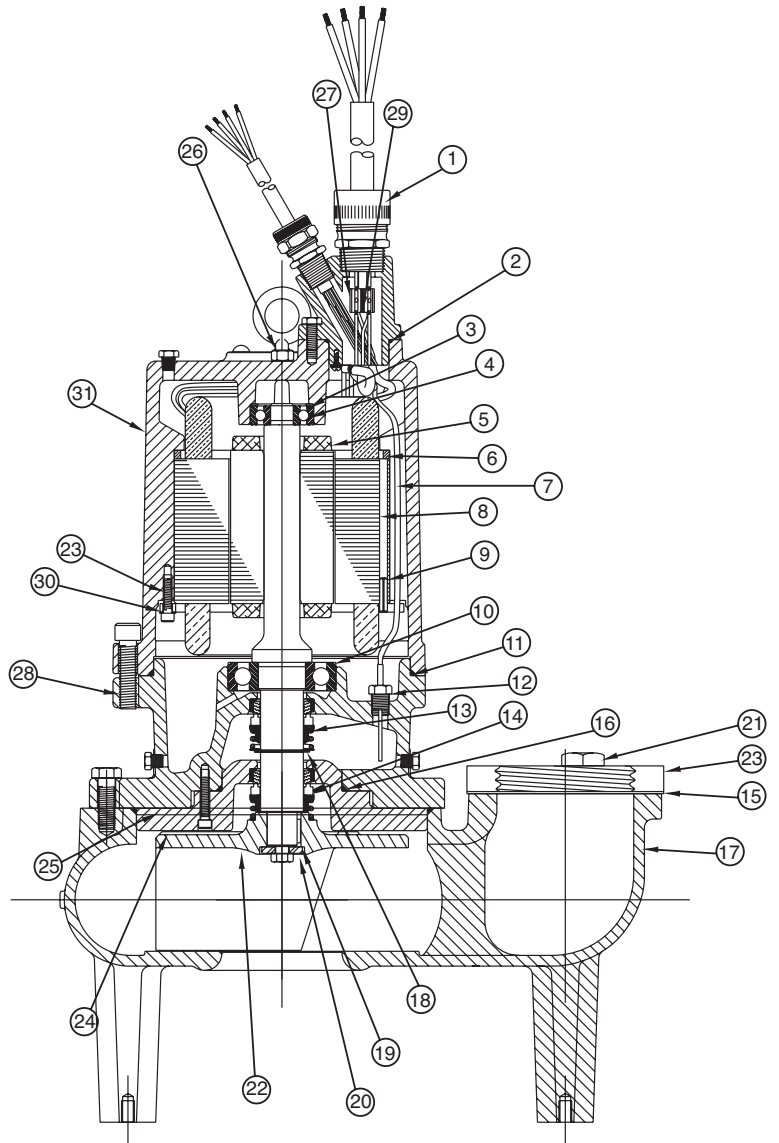

\*— CE-B Carbon Ceramic / Buna-N, TC-B Tungsten Carbide / Buna-N, TC-V Tungsten Carbide / Viton®

## STANDARD LIMITED WARRANTY

Pentair Myers® warrants its products against defects in material and workmanship for a period of 12 months from the date of shipment from Pentair Myers or 18 months from the manufacturing date, whichever occurs first – provided that such products are used in compliance with the requirements of the Pentair Myers catalog and technical manuals for use in pumping raw sewage, municipal wastewater or similar, abrasive-free, noncorrosive liquids.

During the warranty period and subject to the conditions set forth, Pentair Myers, at its discretion, will repair or replace to the original user, the parts that prove defective in materials and workmanship. Pentair Myers reserves the right to change or improve its products or any portions thereof without being obligated to provide such a change or improvement for prior sold and/or shipped units.

Start-up reports and electrical schematics may be required to support warranty claims. Submit at the time of start-up through the Pentair Myers website: <http://forms.pentairliterature.com/startupform/startupform.asp?type=m>. Warranty is effective only if Pentair Myers authorized control panels are used. All seal fail and heat sensing devices must be hooked up, functional and monitored or this warranty will be void. Pentair Myers will cover only the lower seal and labor thereof for all dual seal pumps. Under no circumstance will Pentair Myers be responsible for the cost of field labor, travel expenses, rented equipment, removal/reinstallation costs or freight expenses to and from the factory or an authorized Pentair Myers service facility.

This limited warranty will not apply: (a) to defects or malfunctions resulting from failure to properly install, operate or maintain the unit in accordance with the printed instructions provided; (b) to failures resulting from abuse, accident or negligence; (c) to normal maintenance services and parts used in connection with such service; (d) to units that are not installed in accordance with applicable local codes, ordinances and good trade practices; (e) if the unit is moved from its original installation location; (f) if unit is used for purposes other than for what it is designed and manufactured; (g) to any unit that has been repaired or altered by anyone other than Pentair Myers or an authorized Pentair Myers service provider; (h) to any unit that has been repaired using non factory specified/OEM parts.

Warranty Exclusions: PENTAIR MYERS MAKES NO EXPRESS OR IMPLIED WARRANTIES THAT EXTEND BEYOND THE DESCRIPTION ON THE FACE HEREOF. PENTAIR MYERS SPECIFICALLY DISCLAIMS THE IMPLIED WARRANTIES OF MERCHANTABILITY AND FITNESS FOR ANY PARTICULAR PURPOSE.

Liability Limitation: IN NO EVENT SHALL PENTAIR MYERS BE LIABLE OR RESPONSIBLE FOR CONSEQUENTIAL, INCIDENTAL OR SPECIAL DAMAGES RESULTING FROM OR RELATED IN ANY MANNER TO ANY PENTAIR MYERS PRODUCT OR PARTS THEREOF. PERSONAL INJURY AND/OR PROPERTY DAMAGE MAY RESULT FROM IMPROPER INSTALLATION. PENTAIR MYERS DISCLAIMS ALL LIABILITY, INCLUDING LIABILITY UNDER THIS WARRANTY, FOR IMPROPER INSTALLATION. PENTAIR MYERS RECOMMENDS INSTALLATION BY PROFESSIONALS.

Some states do not permit some or all of the above warranty limitations or the exclusion or limitation of incidental or consequential damages and therefore such limitations may not apply to you. No warranties or representations at any time made by any representatives of Pentair Myers shall vary or expand the provision hereof.



### MYERS®

1101 MYERS PARKWAY  
ASHLAND, OHIO 44805  
PH: 855-274-8947  
WWW.FEMYERS.COM

490 PINEBUSH ROAD, UNIT 4  
CAMBRIDGE, ONTARIO, CANADA N1T 0A5  
PH: 800-363-7867  
WWW.FEMYERS.COM