



MYERS[®]

MODELS WG30/50 & WGX30/50

**STANDARD AND HAZARDOUS LOCATION
3-5 HP SUBMERSIBLE GRINDER PUMPS**



MYERS® MODELS WG30/50 & WGX30/50 Submersible Grinder Pumps

The Right Choice

The Myers WG30/50 are rugged 3–5 horsepower submersible centrifugal grinder pumps designed for residential, light commercial, industrial or municipal applications. They are especially designed for grinder pump applications requiring higher flows at low to moderate heads. The WG30/50 feature a heavy-duty cutter mechanism and recessed impeller design to efficiently grind typical sewage solids into a fine slurry.

WG30/50 grinder pumps are available in standard and FM Listed hazardous location (WGX30/50) construction for use in Class I, Group D hazardous locations.

WG30/50 grinder pumps can be installed in a variety of packaged systems. Factory-assembled simplex or duplex packages with guide rail systems are available.

Individual rail components are also available for installation in on-site concrete systems. Myers offers a complete line of submersible sump, sewage effluent, grinder, solids handling wastewater pumps, controls, basins and accessories. For additional information, contact your local Myers representative or the Myers sales office at 419-289-1144.



Product Capabilities		
Capacities To	185 gpm	693 lpm
Heads To	92 ft.	28.1 m
Liquids Handling	domestic raw sewage	
Intermittent Liquid Temp.	up to 140°F	up to 60°C
Winding Insulation Temp. (Class F)	311°F	155°C
Motor Electrical Data <small>(Single phase motors are capacitor start type. Myers control panels or capacitor kits are recommended for proper operation and warranty.)</small>	3–5 hp, 3450 RPM 1 ph, 230 volt – 3 ph, 200/230/460 volt – 60 Hz	
Std. Third Party Approvals	CSA	
Optional Approvals	FM, Class I, Group D (WGX30/50)	
Acceptable pH Range	6 – 9	
Specific Gravity	.9 – 1.1	
Viscosity	28 – 35 SSU	
Discharge (Flange Dia.)	2-1/2 in.	63.5 mm
Min. Sump Diameter		
Simplex	36 in.	91.4 cm
Duplex	48 in.	121.9 cm

Construction Materials	
Motor Housing, Seal Housing, Cord Cap and Volute Case	cast iron, Class 30, ASTM A48
Impeller	recessed, bronze
Power Cord	SOOW, W
Control Cord	SOOW
Mechanical Seals:	
Standard	double tandem carbon and ceramic
Optional	lower tungsten carbide
Pump, Motor Shaft	416 SST
Fasteners	300 Series SST
Shredding Ring	440 SST,
Grinding Impeller	58-60 Rockwell

Note: Consult factory for applications outside these recommendations.

Pump Features and Applications

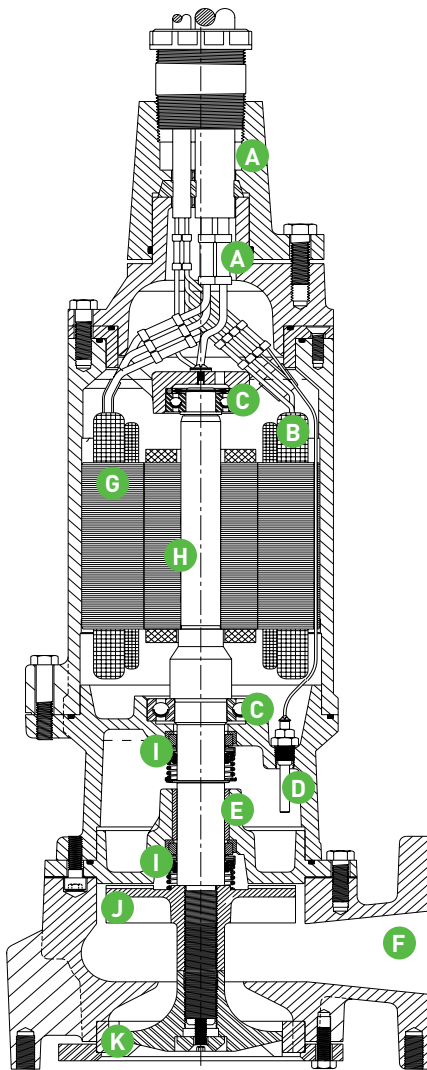

A. Cable Entry System

Provides double seal protection. Cable jacket sealed by compression fitting. Individual wires sealed by epoxy potting.

B. Heat Sensor

Protects motor from burnout due to excessive heat from any overload condition. Automatically resets when motor has cooled.

C. Ball Bearings

Upper and lower ball bearings support shaft and rotor and take axial and radial loads.

D. Seal Leak Probe

Detects water in seal housing; activates warning light in control panel.

E. Sleeve Bearing

Takes radial load; provides flame path. (FM Listed pumps only.)

F. Volute Case

Cast iron, horizontal discharge. Drilled for 2-1/2" pipe flange.

G. Stator

3450 RPM, 1 and 3 phase. Press fit for perfect alignment and best heat transfer. Oil-filled motor conducts heat and lubricates bearings.

H. Heavy 416 SST Shaft

Corrosion resistant. Reduces shaft deflection due to grinding loads.

I. Shaft Seals

Double tandem mechanical shaft seals protect motor. Oil-filled seal chamber provides continuous lubrication.

J. Impeller

Bronze recessed impeller handles ground slurry without clogging or binding. Provides unobstructed flow passage. Reduces radial loads. Pump-out vanes help keep trash from seal, reduce pressure at seal faces.

K. Grinder Assembly

Grinder impeller and shredding ring are replaceable without dismantling pump. Constructed of 440 SST hardened to 56-60 Rockwell.

Ideal for Use in Lift Stations.

- Recessed impeller provides non-overloading high flow operating curve.

The WG30/50 Is Designed for Easy Maintenance.

- Shredding ring and grinder impeller are replaceable without dismantling pump or motor.

Durable Motor Will Deliver Many Years of Reliable Service.

- Oil-filled motor for maximum heat dissipation and constant bearing lubrication.
- Recessed impeller reduces radial bearing loads, increases bearing life.
- High torque capacitor start single phase or three phase motors for assured starting under heavy load.
- Seal leak probes and on-winding heat sensors warn of seal leak condition and stop motor if motor overheats. Help prevent costly motor damage.

Performance Data and Dimensions

3450 RPM

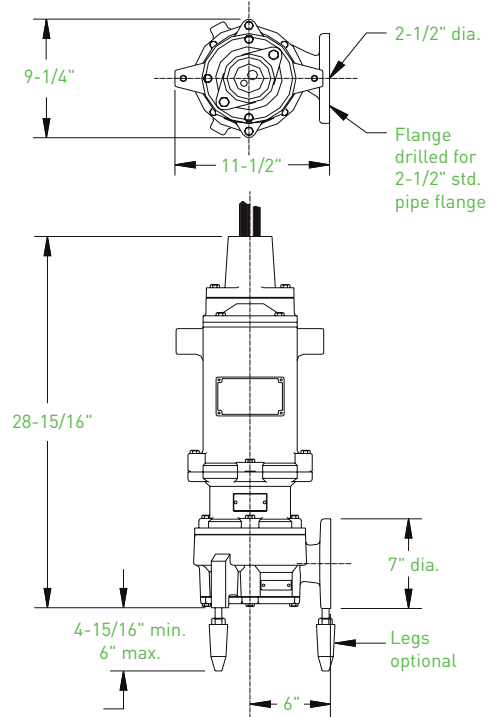
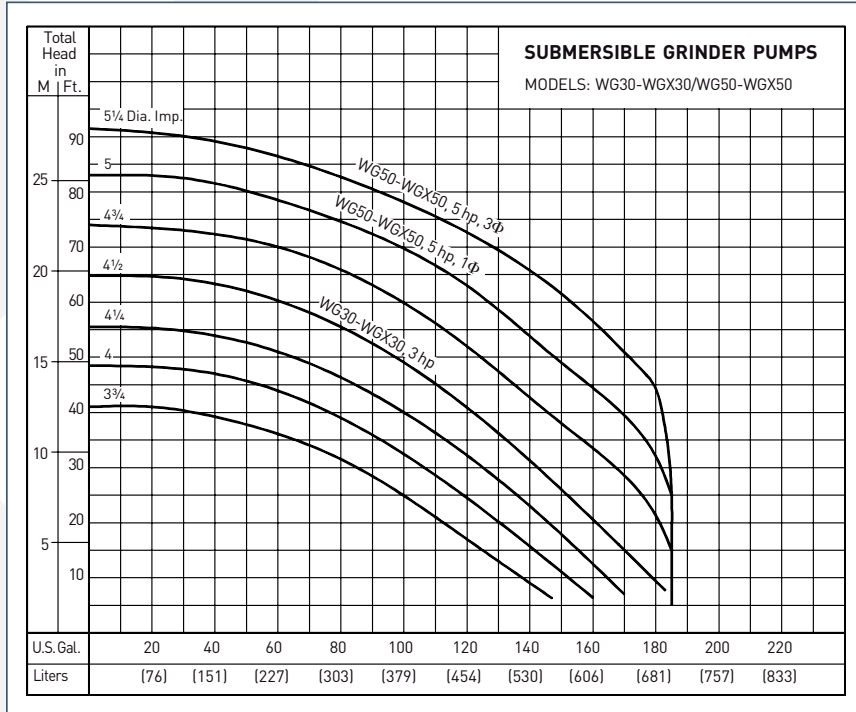

Note: On single phase 5 hp pumps, do not exceed 5" dia. impeller.

Available Models		Motor Electrical Data										
Standard	Hazardous Location	HP	Volts	Phase	Hertz	Start Amps	Full Load Amps	Full Load kW	Start KVA	Full Load KVA	NEC Code Letter	Service Factor
WG30-21	WGX30-21	3	230	1	60	111	30.5	6.5	25.5	7.0	K	2.0
WG30-03	WGX30-03	3	208	3	60	95	19.6	6.0	34.2	7.1	N	2.0
WG30-23	WGX30-23	3	230	3	60	102	17.8	6.0	40.6	7.1	P	2.0
WG30-43	WGX30-43	3	460	3	60	51	8.9	6.0	40.6	7.1	P	2.0
WG30-53	WGX30-53	3	575	3	60	30	7.1	6.0	29.9	7.1	L	2.0
WG50-21	WGX50-21	5	230	1	60	111	35.0	8.0	25.5	8.1	F	1.7
WG50-03	WGX50-03	5	208	3	60	95	24.2	8.0	34.2	8.7	H	1.7
WG50-23	WGX50-23	5	230	3	60	102	21.9	8.0	40.6	8.7	K	1.7
WG50-43	WGX50-43	5	460	3	60	51	10.9	8.0	40.6	8.7	K	1.7
WG50-53	WGX50-53	5	575	3	60	30	8.8	8.0	29.9	8.8	G	1.7



740 EAST 9TH STREET,
ASHLAND, OHIO 44805
WWW.FEMYERS.COM

490 PINEBUSH ROAD, UNIT 4, CAMBRIDGE,
ONTARIO, CANADA N1T 0A5
WWW.FEMYERS.COM