

Panel Wiring Diagram Model DAX1 IR1 PT



Oreco Systems[®]
Incorporated

814 AIRWAY AVENUE
SUTHERLIN, OREGON
97479-9012

TELEPHONE:
(541) 459-4449

FACSIMILE:
(541) 459-2884

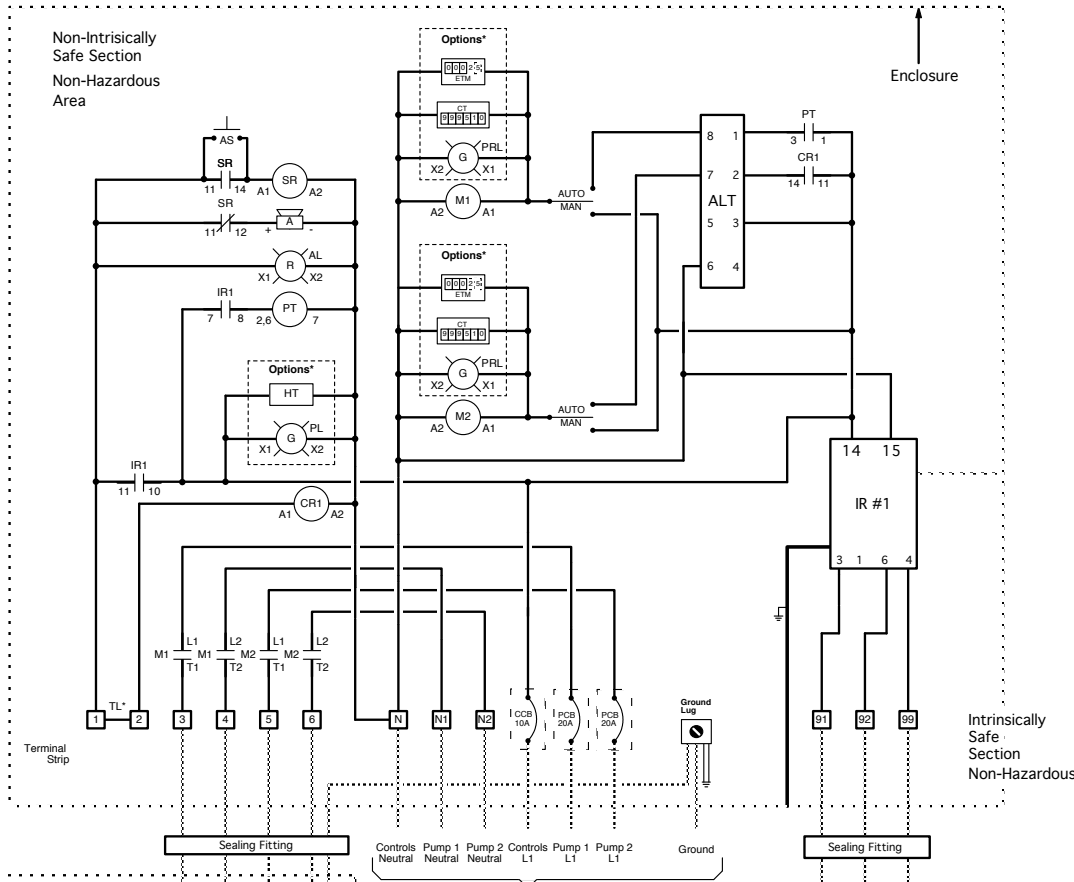

Duplex Operation

High Level Alarm/Timer Override On: This float turns on the lag pump and activates the alarm light and audible alarm when lifted. The audible alarm may be silenced by pressing the illuminated PUSH TO SILENCE button on the front of the control panel. The pump will continue to run and the alarm light will remain on until the Pumps Off float is lowered.

Timer On & Off: This float turns off the programmable timer when lowered. When this float is lifted the timer will be restarted. Note: The timer will start with its off cycle.

Programmable Timer: The timer turns the lead pump on and off in a pre-set cycle. Note: The timer will start with its off cycle.

Key

- = Factory Wire
- = Field Wire
- - - = Alternate Field Wire
- A = Audio Alarm, 115 VAC
- AL = Alarm Light
- ALT = Duplex Alternator
- AS = Audio Silence Switch
- CCB = Controls Circuit Breaker
- CR1 = Override Relay
- IR = Intrinsically Safe Relay
- M = Motor Contactor
- PCB = Pump Circuit Breaker
- PT = Programmable Timer
- SR = Silence Control Relay
- TL = Terminal Link

*Options

- CT = Cycle Counter
- ETM = Elapsed Time Meter
- HT = Heater
- PL = Power Light
- PRL = Pump Run Light

Hazardous Area
Class I Groups A,B,C,D
Class II Groups E,F,G
Class III
NOTE: Motors must have internal overload protection

Pumps
115 VAC / 1 Hp.
1 Phase / 60 Hz.

From Main Power Panel
115 VAC, 1 Phase, 60 Hz.
Main disconnect
provided by others.

Hazardous Area
Class I Groups A,B,C,D
Class II Groups E,F,G
Class III
For float arrangement
diagram, see
drawing no.
"EDW-FA-DAX-503"

NOTE: A spacing of 2 inches
(50mm) must be maintained
between intrinsically safe, and
non-intrinsically safe wiring.

Remote Alarm Connections

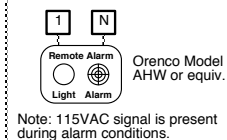

* Removal of Alarm / Override Link Rail

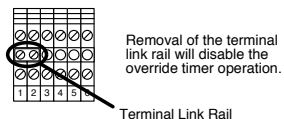

Power Wiring Options

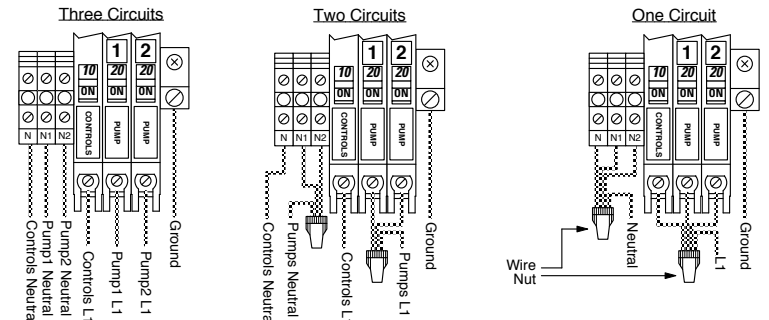

Factory default.
Wire as shown.

Use one wire nut to connect the pole of each pump circuit breaker together with the controls breaker and with the incoming L1 power line. Use another wire nut to connect the neutral block of each pump with the incoming neutral line.

Use one wire nut to connect the pole of each pump circuit breaker together with the controls breaker and with the incoming L1 power line. Use another wire nut to connect the neutral block of each pump with the controls neutral block and with the incoming neutral line.