

Panel Wiring Diagram Model DAX1 PT RO CS(a)

From Main Power Panel
115 VAC, 1 Phase, 60 Hz.
Main disconnect
provided by others.

— = Factory Wire
- - - = Field Wire

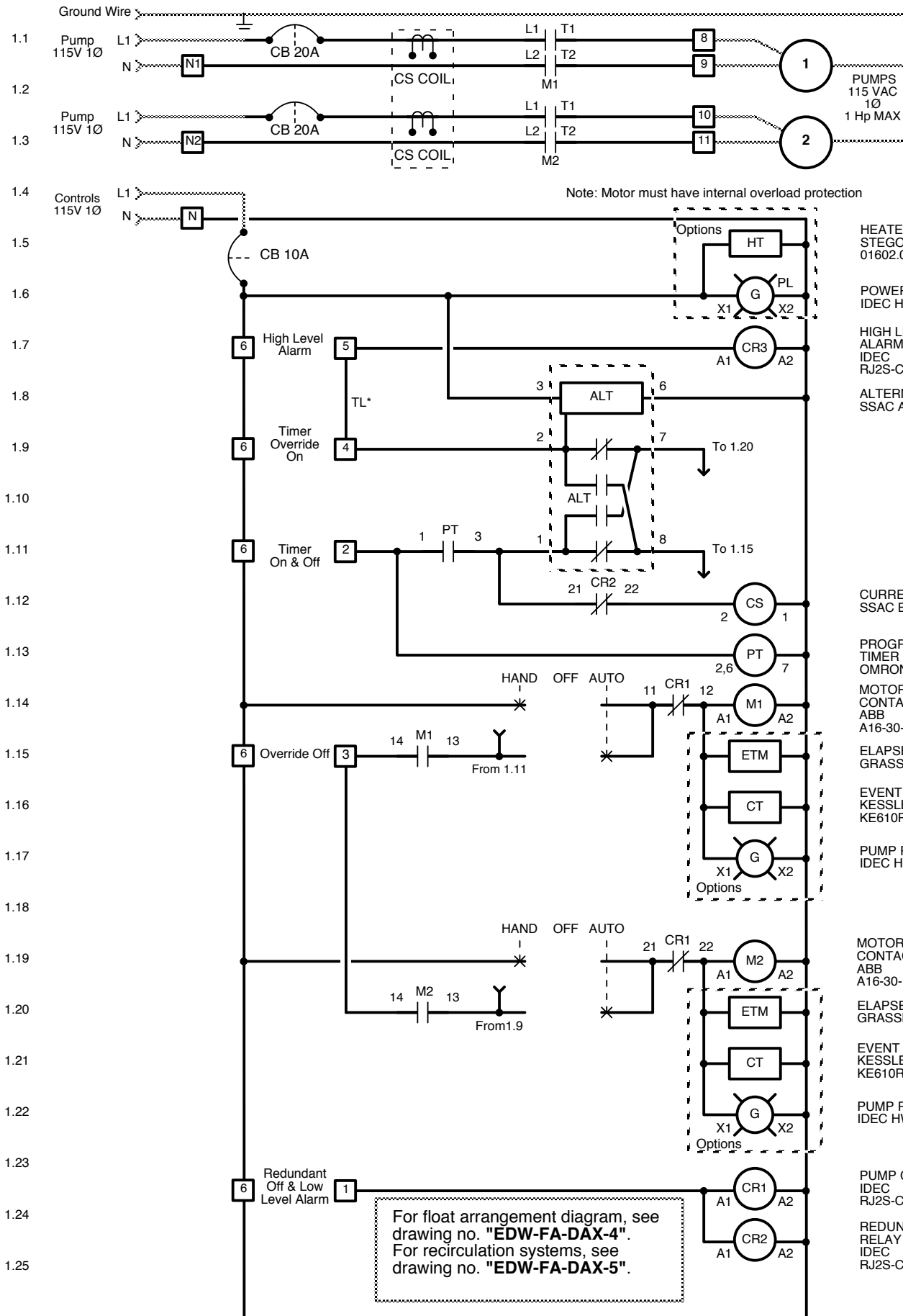

814 AIRWAY AVENUE
SUTHERLIN, OREGON
97479

TOLL FREE:
(800) 348-9843

TELEPHONE:
(541) 459-4449

FACSIMILE:
(541) 459-2884

WEB SITE:
www.orenco.com

HEATER
STEGO
01602.0-09

POWER LIGHT
IDEC HW SERIES

HIGH LEVEL
ALARM RELAY
IDEC
RJ2S-C-A120

ALTERNATING RELAY
SSAC ARP43S

CURRENT SENSOR
SSAC ECS41BC

PROGRAMMABLE
TIMER
OMRON HC3R-F8

MOTOR
CONTACTOR
ABB
A16-30-10-84

ELAPSED TIME METER
GRASSLIN UWZ48 120V

EVENT COUNTER
KESSLER-ELLIS
KE610RB10AC120

PUMP RUN LIGHT
IDEC HW SERIES

MOTOR
CONTACTOR
ABB
A16-30-10-84

ELAPSED TIME METER
GRASSLIN UWZ48 120V

EVENT COUNTER
KESSLER-ELLIS
KE610RB10AC120

PUMP RUN LIGHT
IDEC HW SERIES

PUMP CUT-OFF RELAY
IDEC
RJ2S-C-A120

REDUNDANT OFF
RELAY
IDEC
RJ2S-C-A120

For float arrangement diagram, see
drawing no. "EDW-FA-DAX-4".
For recirculation systems, see
drawing no. "EDW-FA-DAX-5".

2.1
2.2
2.3
2.4
2.5
2.6
2.7
2.8
2.9
2.10
2.11
2.12
2.13
2.14
2.15
2.16
2.17
2.18
2.19
2.20
2.21
2.22
2.23
2.24
2.25
2.26
2.27
2.28
2.29

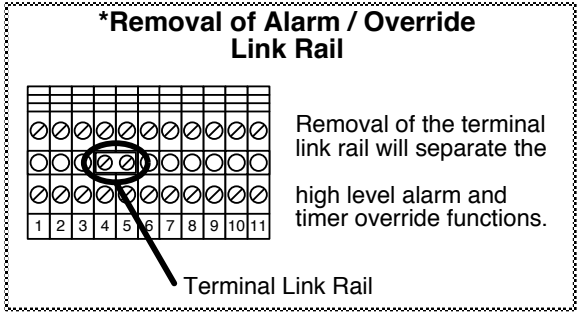
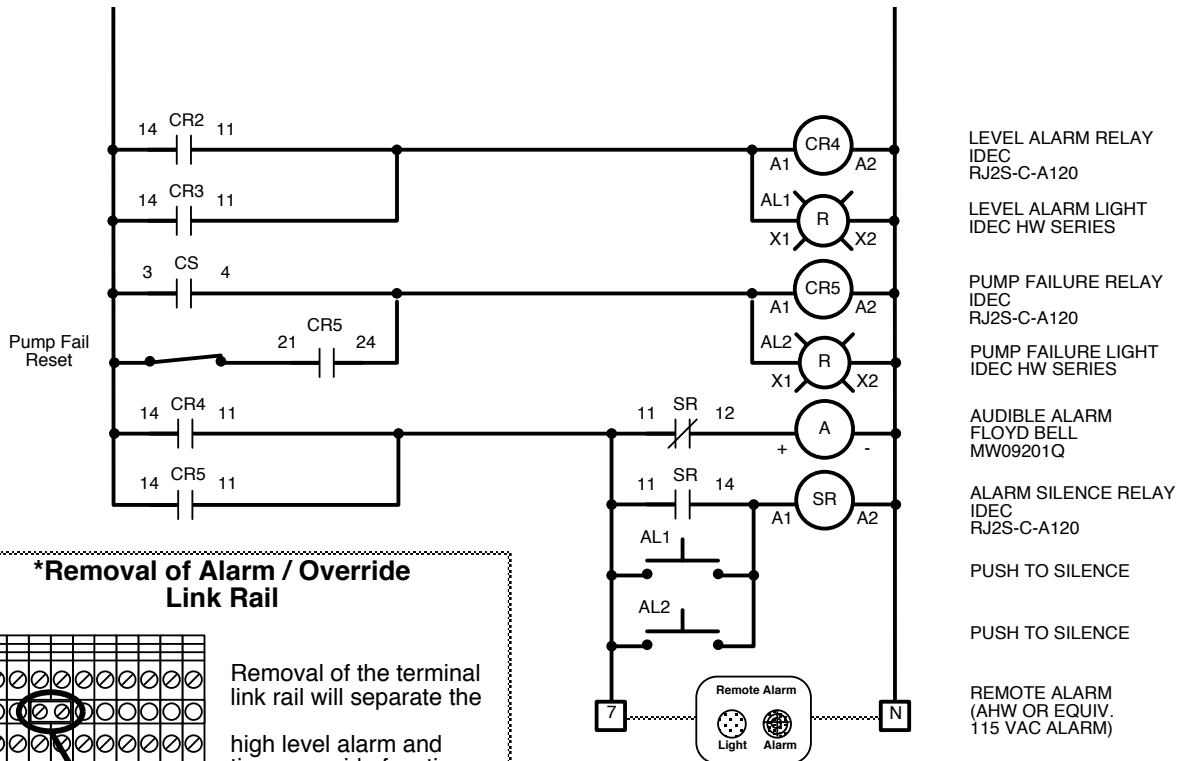

DUPLEX OPERATION

- High Level Alarm:** This float activates the alarm light and audible alarm when lifted. The audible alarm may be silenced by pressing the illuminated PUSH TO SILENCE button on the front of the control panel. The alarm light will remain on until the float is lowered.
- Timer Override On:** This float turns on the lag pump when lifted.
- Timer Override Off:** When lowered, this float turns off any pump(s) which were started by the Timer Override On float.
- Timer On & Off:** This float turns off the programmable timer when lowered. When this float is lifted the timer will be restarted. Note: The timer will start with its off cycle.
- Redundant Off & Low Level Alarm:** This float turns off the pump(s) when lowered. This float is a secondary off float which will operate if the Timer On & Off float fails. Pumping will be disabled in both the automatic and manual modes. This float also activates the alarm light and audible alarm. The audible alarm may be silenced by pressing the illuminated PUSH TO SILENCE button on the front of the control panel. The alarm light will remain on until the float is lifted.
- Programmable Timer:** The timer turns the lead pump on and off in a pre-set cycle. Note: The timer will start with its off cycle.
- Current Sensor Pump Fail Alarm:** If a pump fails to come on, this sensor activates the pump fail alarm light and audible alarm. The audible alarm may be silenced by pressing the illuminated PUSH TO SILENCE button on the front of the control panel. The alarm light will remain on until the condition is corrected and the pump fail alarm reset switch is operated.

