

Panel Wiring Diagram Model MVP-DAX2 PTR0

814 AIRWAY AVENUE
SUTHERLIN, OREGON
97479-9012
TELEPHONE:
(541) 459-4449
FACSIMILE:
(541) 459-2884

- Key**
- = Factory Wire
 - - - = Field Wire
 - · - = Alternate Field Wire
 - A = Audio Alarm, 115 VAC
 - AL = Alarm Light
 - AS = Audio Silence Switch
 - CCB = Controls Circuit Breaker
 - Logo = Logic Module
 - M = Motor Contactor
 - PCB = Pump Circuit Breaker
 - TL = Terminal Link
- *Options**
- HT = Heater
 - PL = Power Light
 - PRL = Pump Run Light

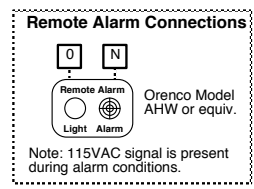
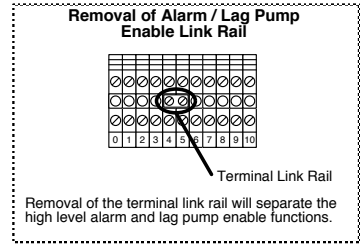

For MVP-DAX operation description, see drawing no. "EIN-CP-OP-4".

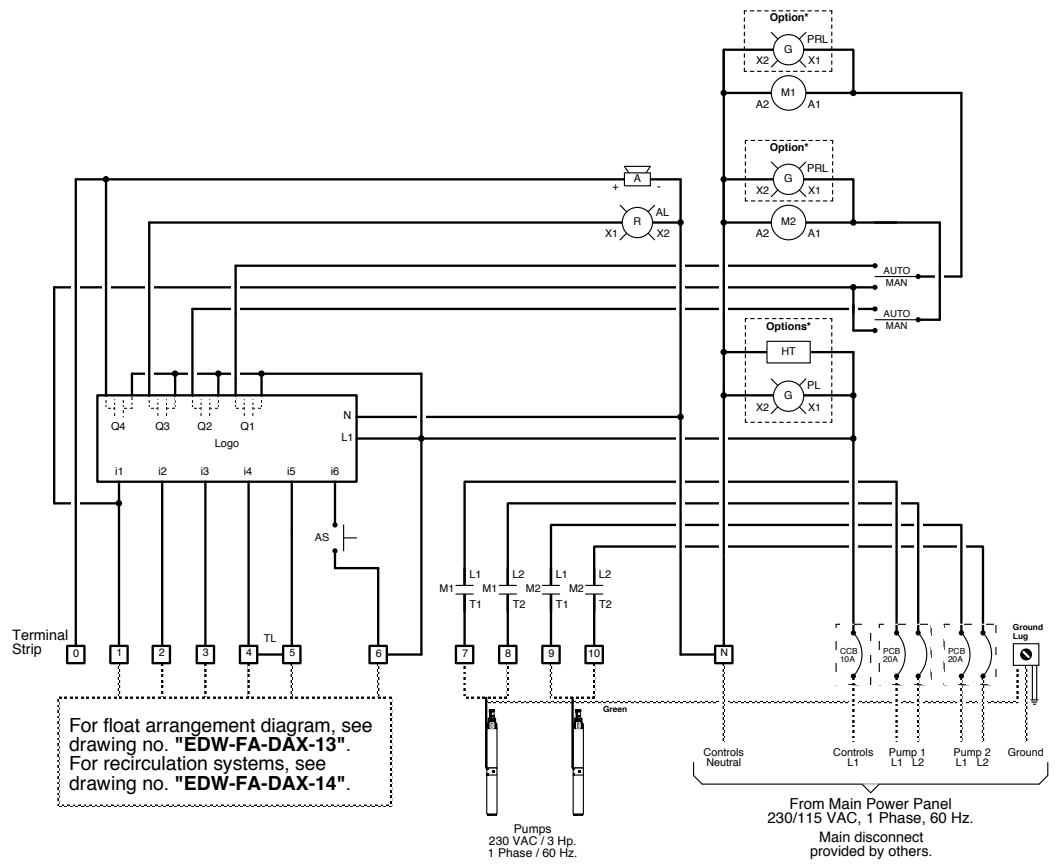

For float arrangement diagram, see drawing no. "EDW-FA-DAX-13".
For recirculation systems, see drawing no. "EDW-FA-DAX-14".

NOTE: Motors must have internal overload protection

