

Panel Wiring Diagram Model MVP-S2 PT RO SA



Oreco Systems
Incorporated

814 AIRWAY AVENUE

SUTHERLIN, OREGON

97479-9012

TELEPHONE:

(541) 459-4449

FACSIMILE:

(541) 459-2884

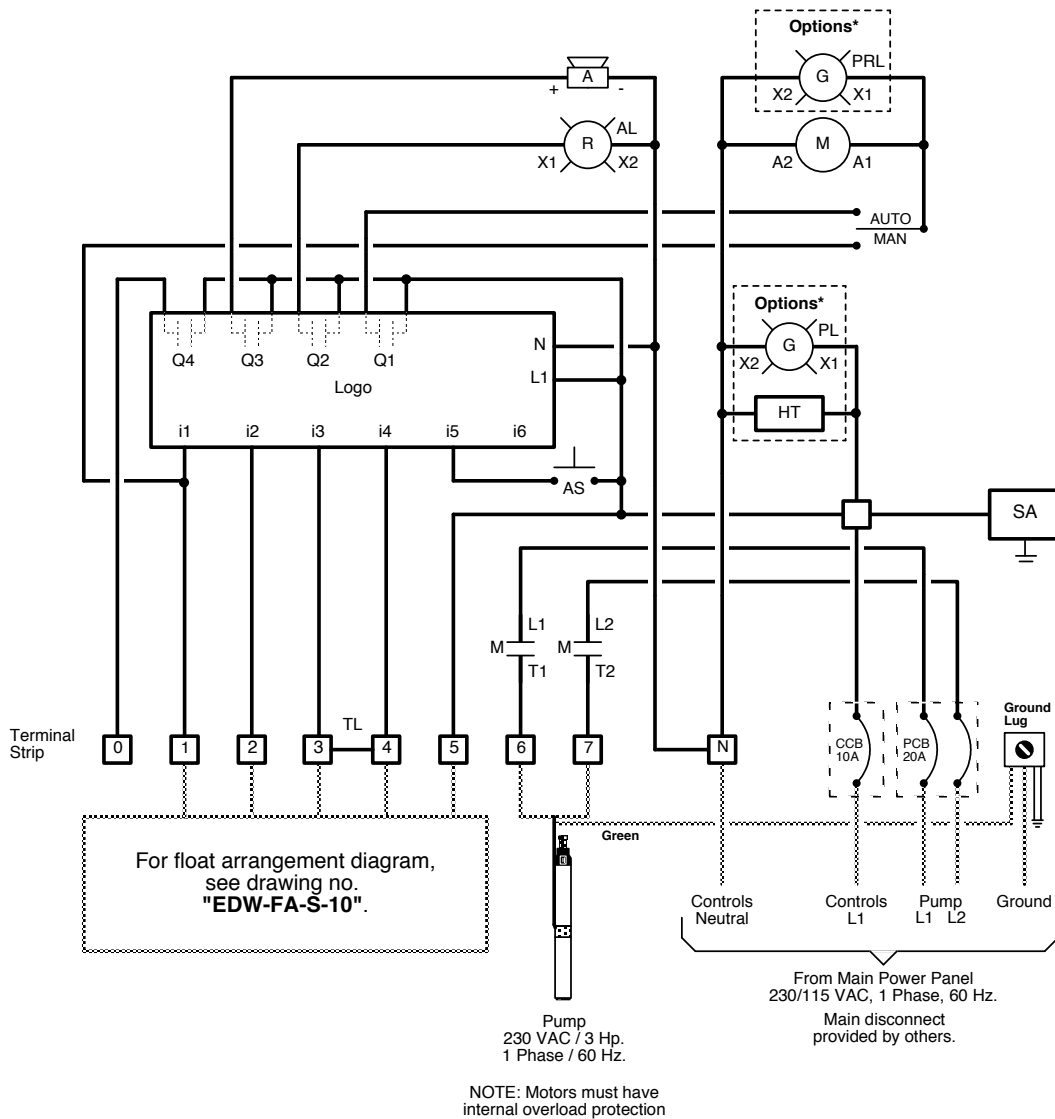

Key

- = Factory Wire
 - = Field Wire
 - - - = Alternate Field Wire
 - A = Audio Alarm, 115 VAC
 - AL = Alarm Light
 - AS = Audio Silence Switch
 - CCB = Controls Circuit Breaker
 - Logo = Logic Module
 - M = Motor Contactor
 - PCB = Pump Circuit Breaker
 - SA = Surge Arrestor
 - TL = Terminal Link
- *Options**
- HT = Heater
 - PL = Power Light
 - PRL = Pump Run Light

