

Panel Wiring Diagram Model DAX2 RO

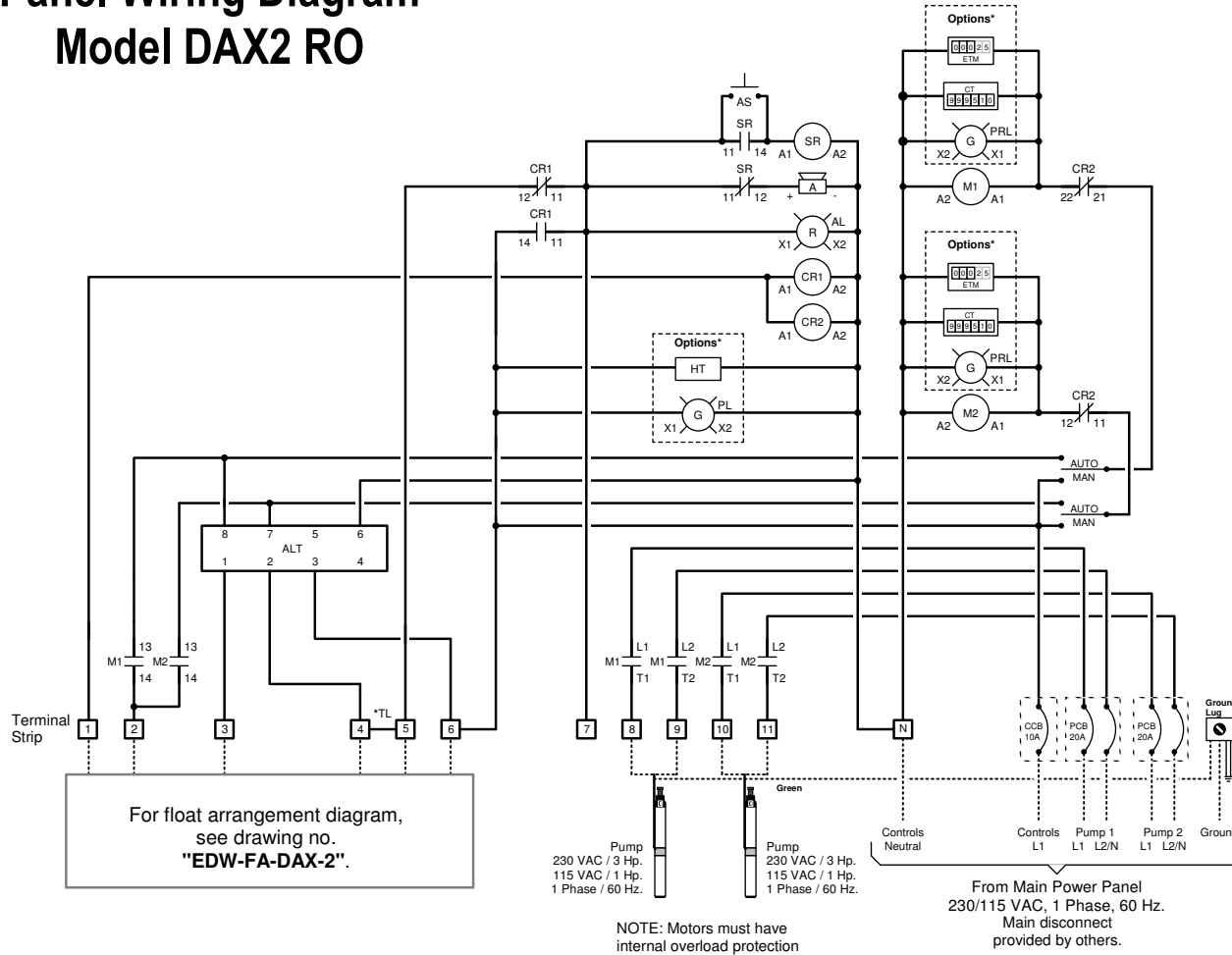

Duplex Operation

High Level Alarm: This float activates the alarm light and audible alarm when lifted. The audible alarm may be silenced by pressing the illuminated PUSH TO SILENCE button on the front of the control panel. The alarm light will remain on until the float is lowered.

Lag Pump On: This float turns on the lag pump when lifted. The pump will continue to run until the Pumps Off float is lowered.

Lead Pump On: This float turns on the lead pump when lifted. The pump will continue to run until the Pumps Off float is lowered.

Pumps Off: This float turns off the pumps when lowered.

Redundant Off & Low Level Alarm: This float turns off the pump(s) when lowered. This float is a secondary off float which will operate if the Pumps Off float fails. Pumping will be disabled in both the automatic and manual modes. This float also activates the alarm light and audible alarm. The audible alarm may be silenced by pressing the illuminated PUSH TO SILENCE button on the front of the control panel. The alarm light will remain on until the float is lifted.

Key

- = Factory Wire
- = Field Wire
- - - = Alternate Field Wire
- A = Audio Alarm, 115 VAC
- AL = Alarm Light
- ALT = Duplex Alternator
- AS = Audio Silence Switch
- CCB = Controls Circuit Breaker
- CR1 = Low Level Alarm Relay
- CR2 = Redundant Off Relay
- M = Motor Contactor
- PCB = Pump Circuit Breaker
- SR = Silence Control Relay
- TL = Terminal Link

*Options

- CT = Cycle Counter
- ETM = Elapsed Time Meter
- HT = Heater
- PL = Power Light
- PRL = Pump Run Light

Remote Alarm Connections

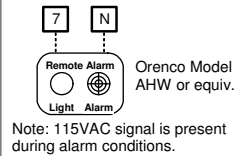

*Removal of Alarm / Lag Link Rail

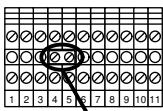

Terminal Link Rail

Removal of the terminal link rail will separate the high level alarm and Lag Pump On functions.

*Power Wiring Options: 230 VAC Pumps

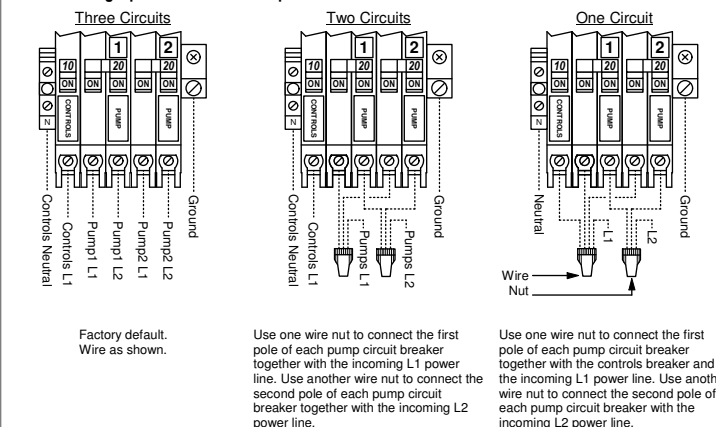

*Power Wiring Options: 115 VAC Pumps

