

Panel Wiring Diagram Model A1 ETM TS



Oreco Systems®
Incorporated

814 AIRWAY AVENUE

SUTHERLIN, OREGON

97479-9012

TELEPHONE:

(541) 459-4449

FACSIMILE:

(541) 459-2884

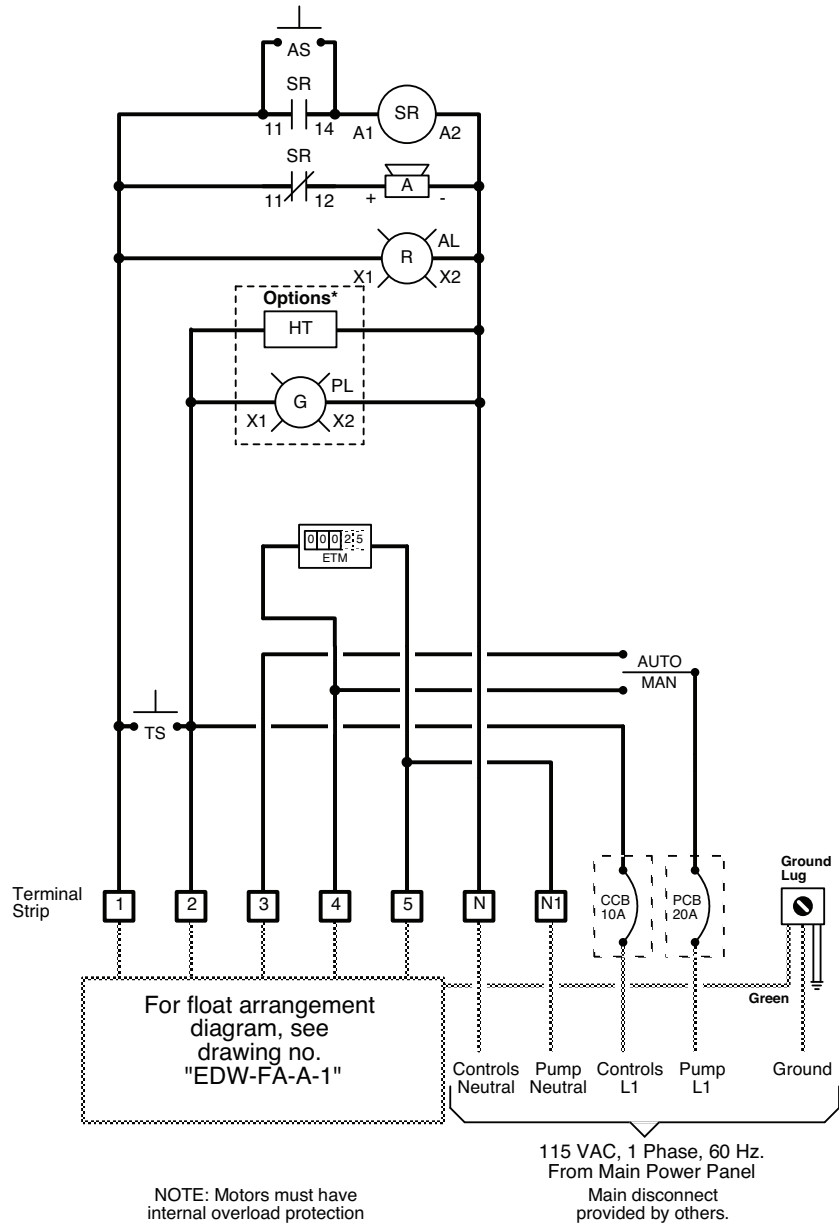

Simplex Operation

High Level Alarm: This float activates the alarm light and audible alarm when lifted. The audible alarm may be silenced by pressing the illuminated PUSH TO SILENCE button on the front of the control panel. The alarm light will remain on until the float is lowered.

Pump On & Off: This float turns on the pump when lifted and off when lowered.

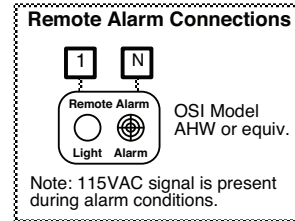

Key

- = Factory Wire
- = Field Wire
- - - = Alternate Field Wire
- A = Audio Alarm, 115 VAC
- AL = Alarm Light
- AS = Audio Silence Switch
- CCB = Controls Circuit Breaker
- ETM = Elapsed Time Meter
- PCB = Pump Circuit Breaker
- SR = Silence Relay
- TS = Alarm Test Switch

- *Options**
- HT = Heater
 - PL = Power Light

