

Control Panel Wiring Diagram

Model MVP-DAX1 DM SA

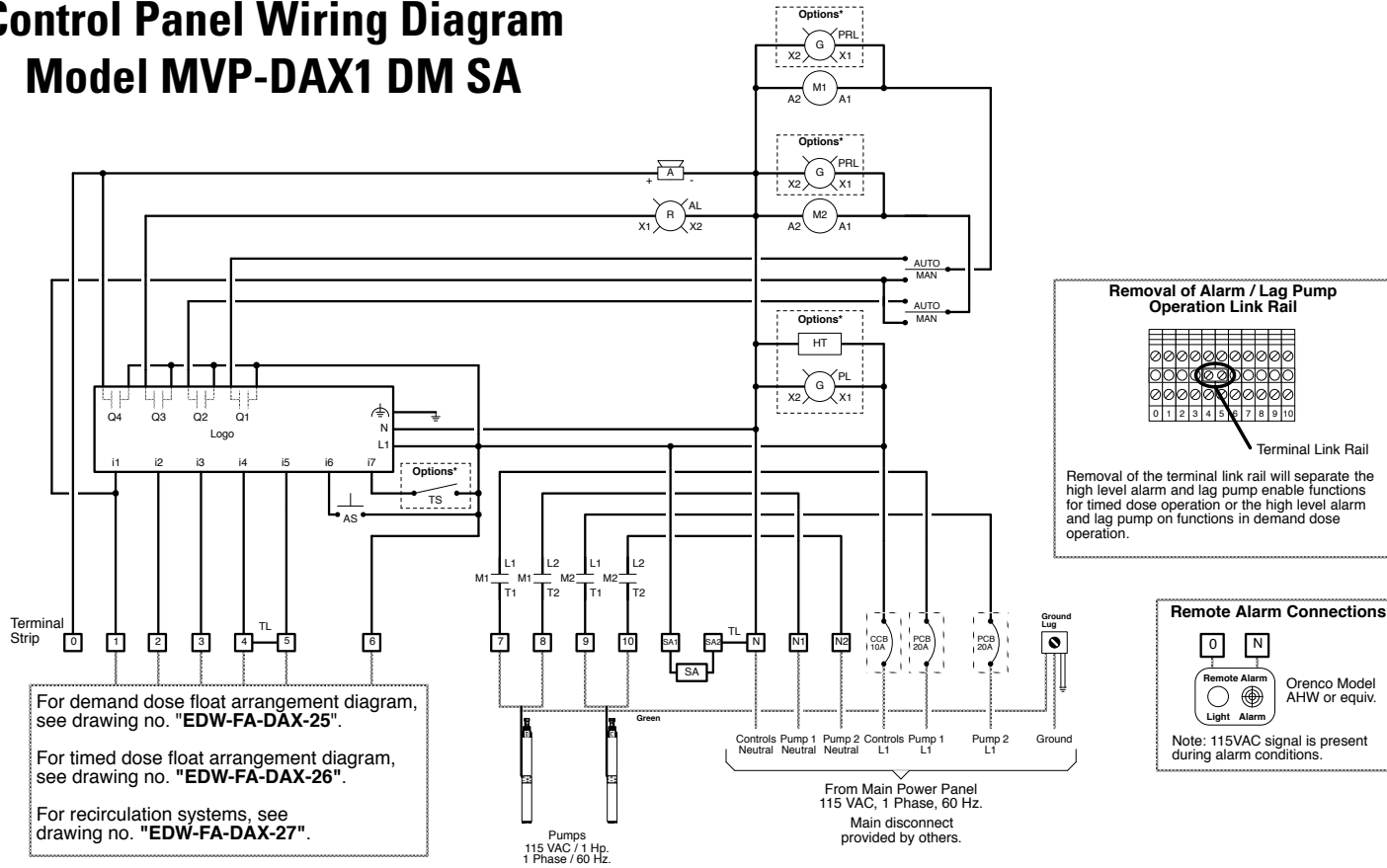

For demand dose float arrangement diagram, see drawing no. "EDW-FA-DAX-25".

For timed dose float arrangement diagram, see drawing no. "EDW-FA-DAX-26".

For recirculation systems, see drawing no. "EDW-FA-DAX-27".

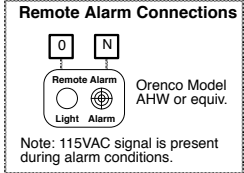
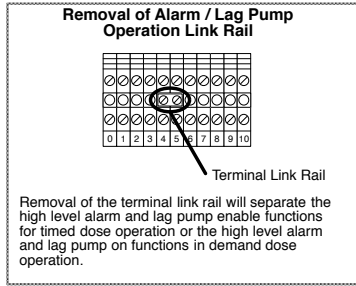

- ### Key
- = Factory Wire
 - - - = Field Wire
 - · - = Alternate Field Wire
 - A = Audio Alarm, 115 VAC
 - AL = Alarm Light
 - AS = Audio Silence Switch
 - CCB = Logic Module
 - Logo = Motor Contactor
 - M = Pump Circuit Breaker
 - PCB = Terminal Link
 - TL = Terminal Link
- ### *Options
- HT = Heater
 - PL = Power Light
 - PRL = Pump Run Light
 - SA = Surge Arrester

For MVP-DAX DM operation description, see drawing no. "EIN-CP-OP-2042".

NOTE: Motors must have internal overload protection

