

# Panel Wiring Diagram Model MVP-DAX1 RO



Oreco Systems®  
Incorporated

814 AIRWAY AVENUE  
SUTHERLIN, OREGON  
97479-9012

TELEPHONE:  
(541) 459-4449

FACSIMILE:  
(541) 459-2884

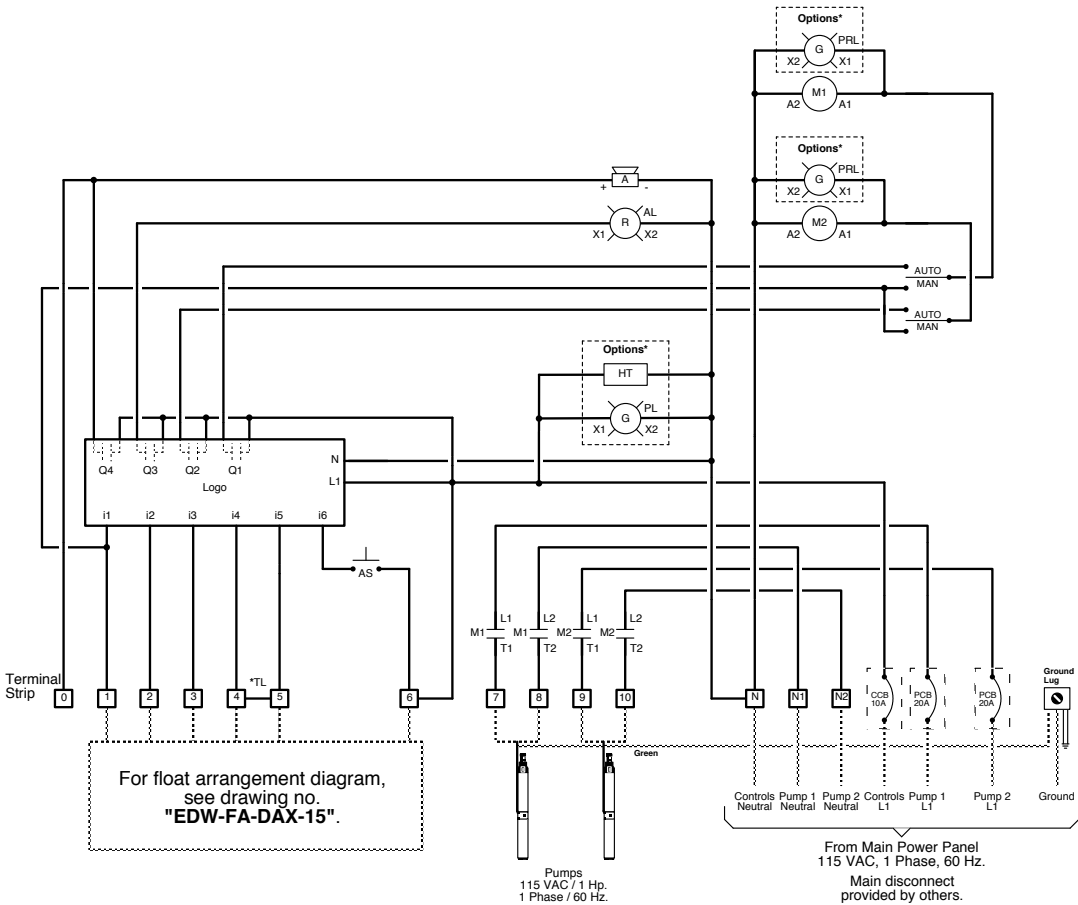

For float arrangement diagram,  
see drawing no.  
"EDW-FA-DAX-15".

NOTE: Motors must have  
internal overload protection

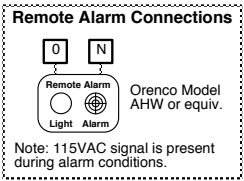
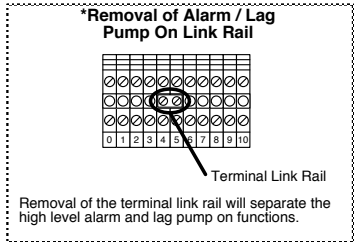

- Key**
- = Factory Wire
  - - - = Field Wire
  - · - = Alternate Field Wire
  - AL = Audio Alarm, 115 VAC
  - AL = Alarm Light
  - AS = Audio Silence Switch
  - CCB = Controls Circuit Breaker
  - Logo = Logic Module
  - M = Motor Contactor
  - PCB = Pump Circuit Breaker
  - TL = Terminal Link
- \*Options**
- HT = Heater
  - PL = Power Light
  - PRL = Pump Run Light

For MVP-DAX RO  
operation  
description, see  
drawing no.  
"EIN-CP-OP-85".

