

Panel Wiring Diagram Model A2



Oreco Systems®
Incorporated

814 AIRWAY AVENUE

SUTHERLIN, OREGON

97479-9012

TELEPHONE:

(541) 459-4449

FACSIMILE:

(541) 459-2884

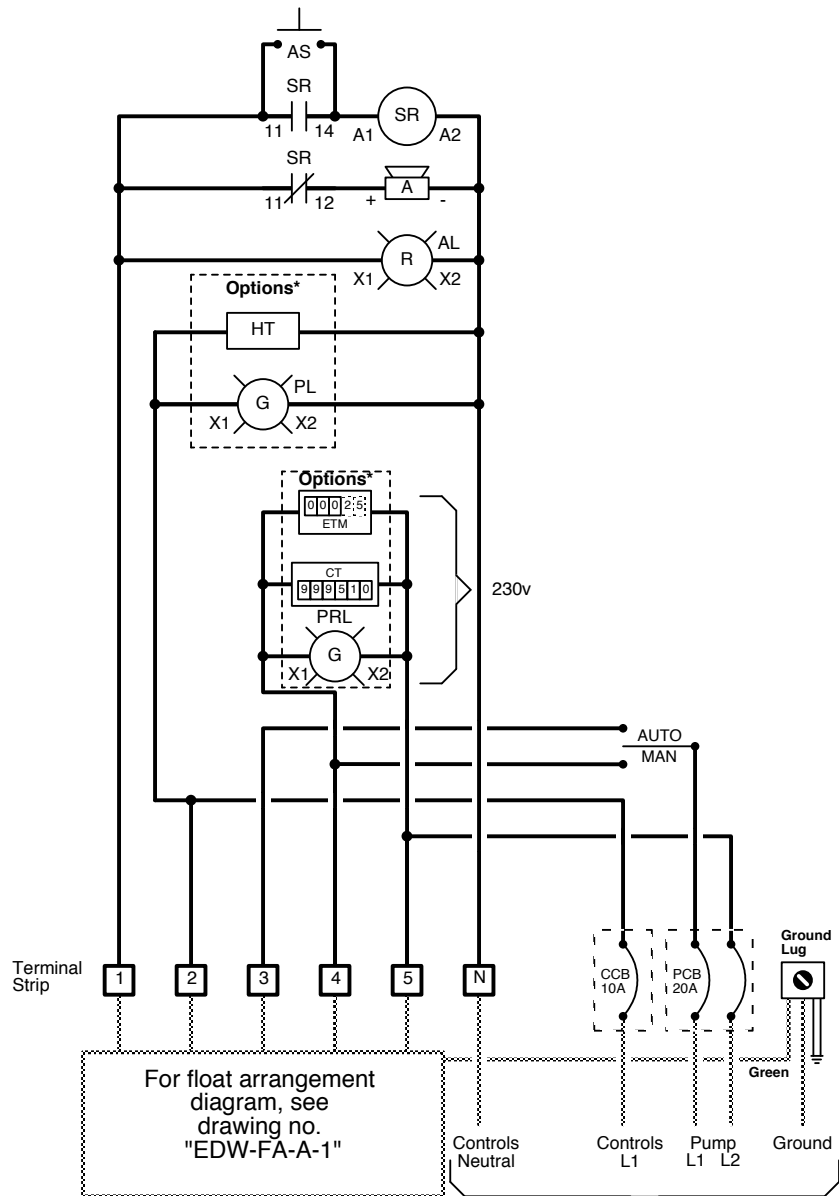

NOTE: Motors must have internal overload protection

230/115 VAC, 1 Phase, 60 Hz.
From Main Power Panel
Main disconnect provided by others.

Simplex Operation

High Level Alarm: This float activates the alarm light and audible alarm when lifted. The audible alarm may be silenced by pressing the illuminated PUSH TO SILENCE button on the front of the control panel. The alarm light will remain on until the float is lowered.

Pump On & Off: This float turns on the pump when lifted and off when lowered.

Key

- = Factory Wire
- ⋯ = Field Wire
- - - = Alternate Field Wire
- A = Audio Alarm, 115 VAC
- AL = Alarm Light
- AS = Audio Silence Switch
- CCB = Controls Circuit Breaker
- PCB = Pump Circuit Breaker
- SR = Silence Control Relay

*Options

- CT = Cycle Counter
- ETM = Elapsed Time Meter
- HT = Heater
- PL = Power Light
- PRL = Pump Run Light

