

Model: PF2020HCU

Features:

Suitable for general industrial use such as liquid transfer or as booster pumps.

- **DISCHARGE:** 2" 125 lb. ANSI, Discharge can be placed in 8 different locations depending on piping requirements
- **SUCTION:** 2" NPT
- **LIQUID TEMPERATURE:** 180°F Continuous
- **BODY:** Cast Iron, ASTM Class 30, with Air Vent, Vacuum Pressure and Drain Plugs
- **PEDESTAL:** Cast iron, Class 30
- **IMPELLER:** Enclosed type, Dynamically balanced, ISO G6.3, Bronze 81-3-7-9
- **WEAR RING:** Teflon "U" Cup
- **SHAFT:** Steel
- **SHAFT SLEEVE:** Bronze
- **PAINT:** Air dry enamel
- **HARDWARE:** Steel
- **SEAL:** Single mechanical, Self lubrication, Carbon/Ni-Resist/Buna-N
- **BEARING - PUMP END:** Single row, ball, Pre-Greased at Factory Load- Radial & Thrust
- **BEARING - DRIVE END:** Double Row, Ball, Pre-Greased at Factory Load- Radial & Thrust
- **WEIGHT:** 74 lbs.
- **WARRANTY:** 1 year



**End Suction
2" Suction x 2" Discharge
Universal Drive**

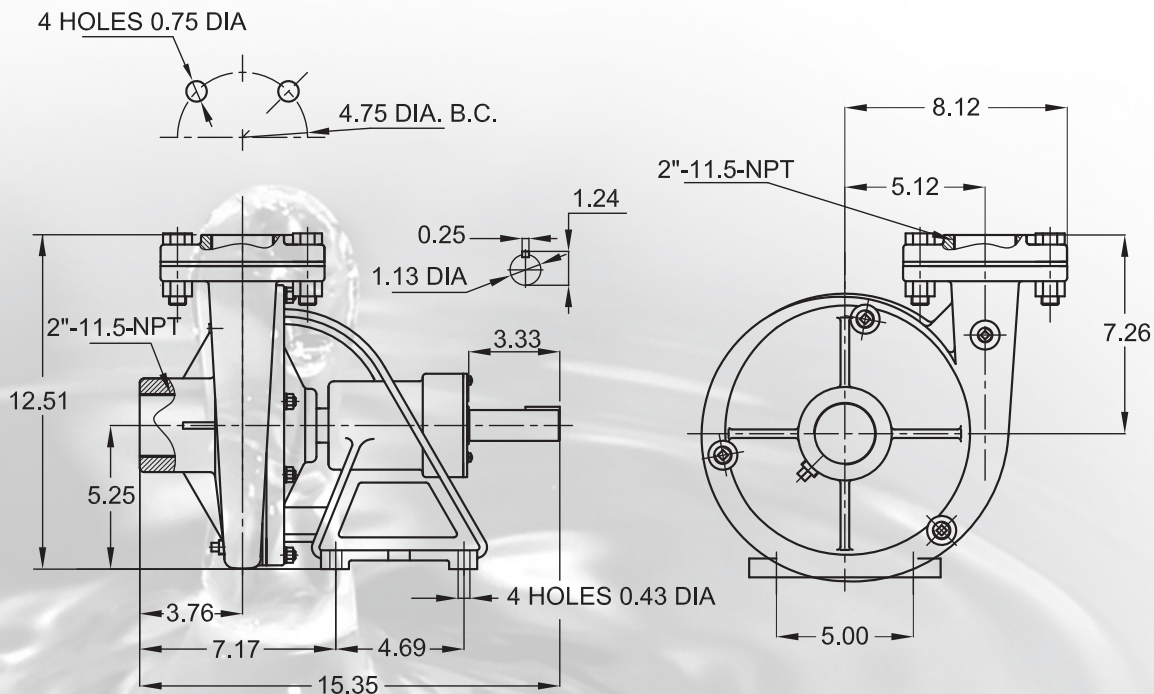

WARNING ! - DO NOT use in explosive atmosphere or for pumping volatile flammable liquids.

Model: PF2020HCU - Various RPM

End Suction Centrifugal Pumps - 2" x 2" - Universal Drive

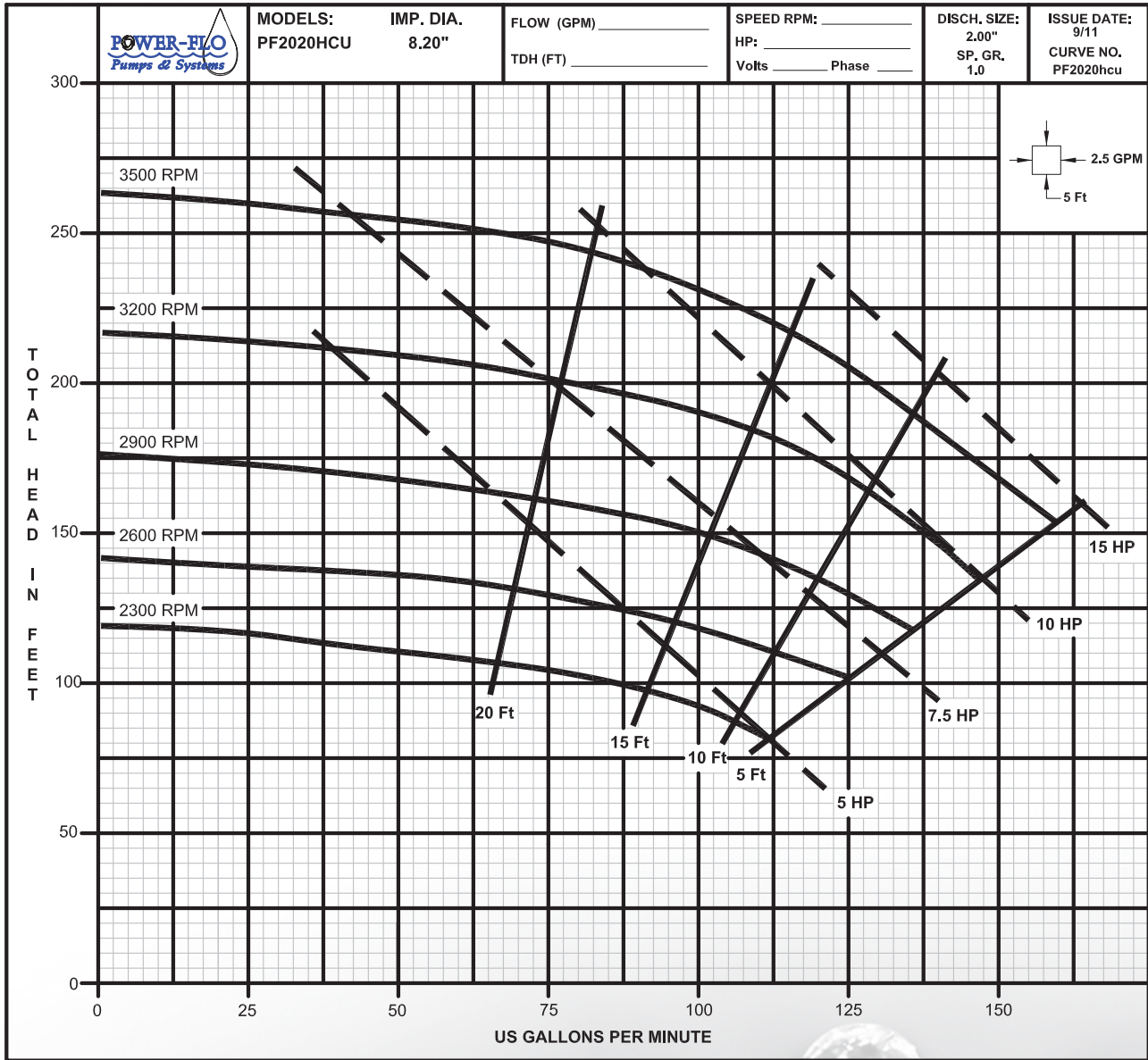

Model: PF2020HCU - Various Impeller Diameters at 3500RPM

End Suction Centrifugal Pumps - 2" x 2" - Universal Drive

