

Model: PF20ICU



**Self-Priming,
Frame Mounted Pumps
Universal Drive**

Features:

Self-priming centrifugal frame mounted pumps designed for industrial, Municipal and Marine applications.

- **SUCTION/DISCHARGE:** 3" x 3" NPT, Female
- **LIQUID TEMPERATURE:** 160°F Continuous
- **VOLUTE:** Removable, Cast Iron, ASTM, Class 30
- **BODY:** Cast Iron, ASTM, Class 30
- **PEDESTAL:** Cast Iron, ASTM, Class 30
- **PAINT:** Air dry enamel
- **O-RINGS:** Buna-N
- **SHAFT:** Stainless steel
- **SHAFT SLEEVE:** Stainless steel
- **HARDWARE:** Steel & Stainless steel
- **IMPELLER:** Open, trash type, dynamically balanced, Cast Iron, Class 30
- **SEAL:** Single Mechanical, with Lip Seal , Grease Lubricated, Carbon/Ceramic/Buna-N,
- **CHECK VALVE:** Valve Flap-Neoprene, Weight- Steel
- **BEARING-DRIVE END:** Single Row, Ball, Grease Lubricated
- **BEARING-PUMP END:** Single Row, Ball, Grease Lubricated
- **WARRANTY:** 1 year
- **WEIGHT:** 224 lbs

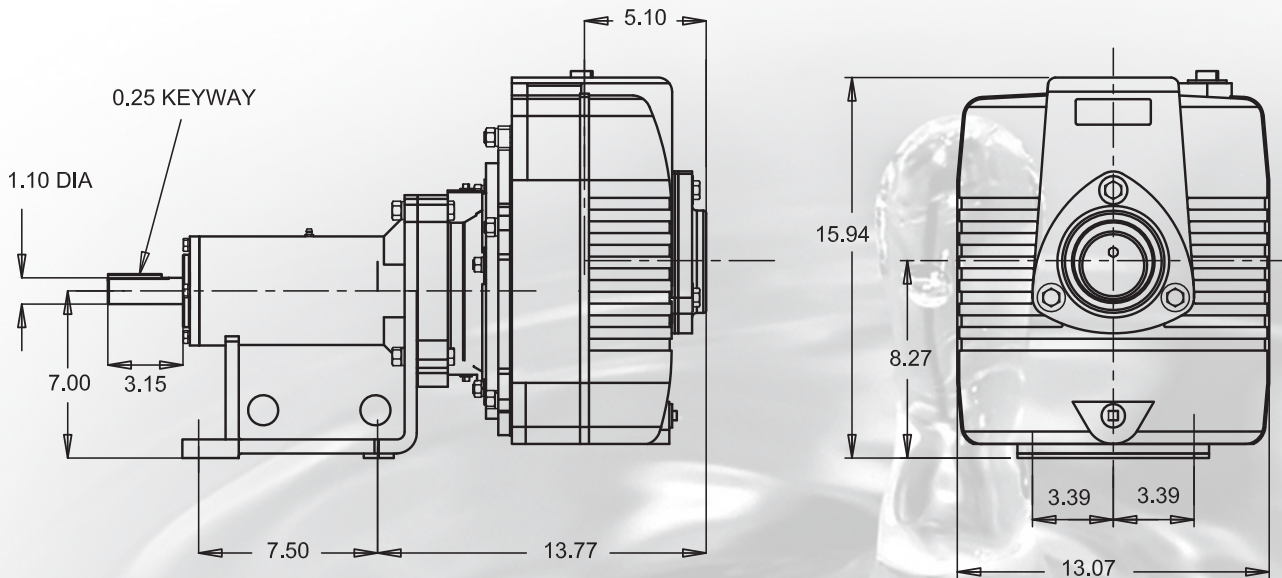

Not for pumping flammable liquids or hazardous materials that is not compatible with pump materials.

Model: PF20ICU

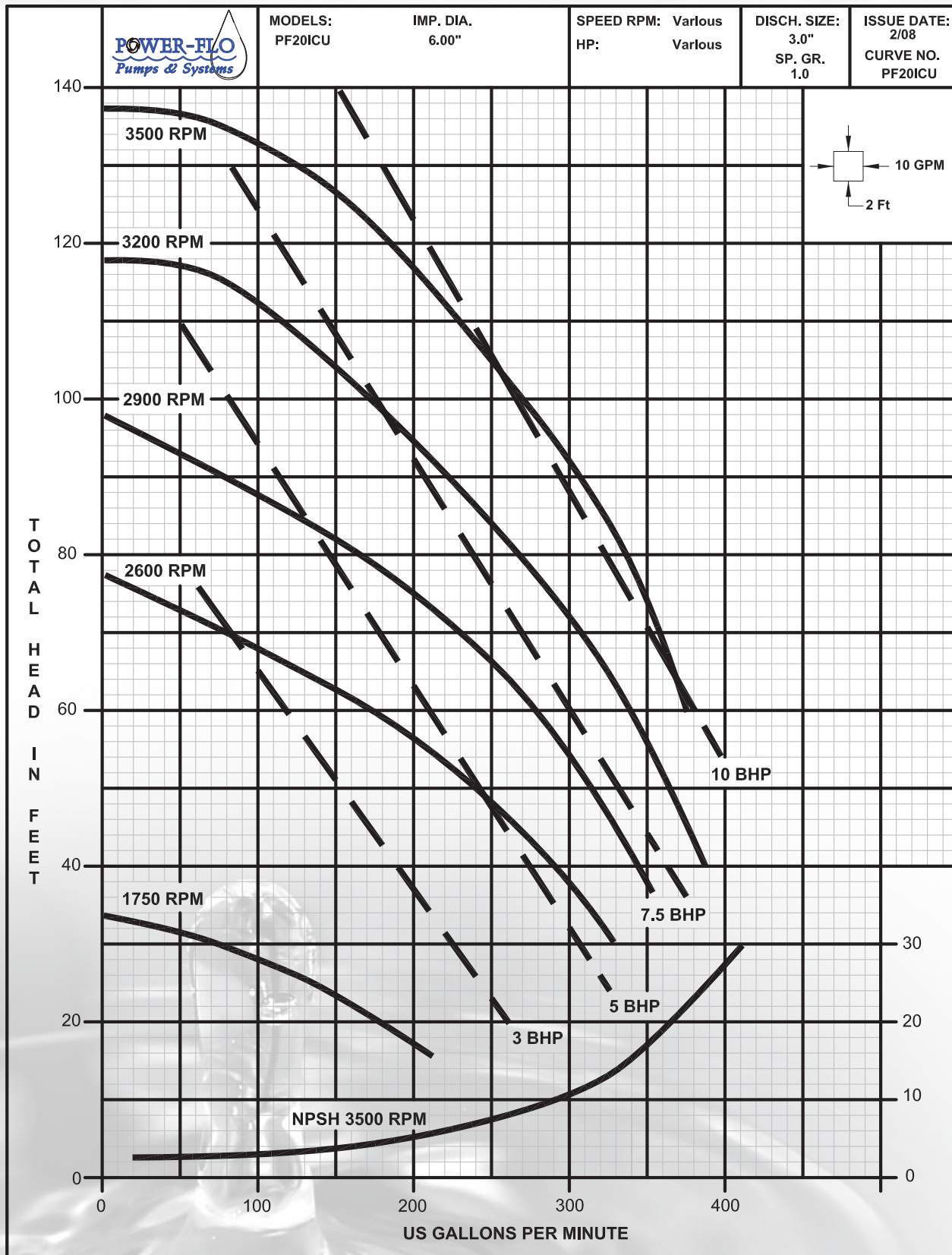

Self-Priming Centrifugal Pumps - PFICU - 3" x 3" NPT