

# INSTALLATION, SERVICE & PARTS MANUAL

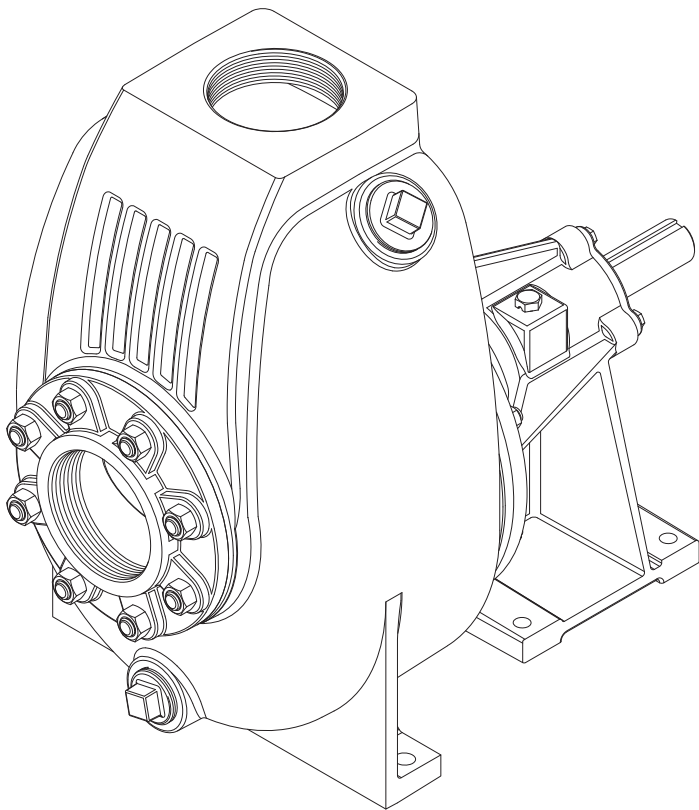

**Series: PF30MU  
PF40MU**

***Self-Priming Frame  
Mounted Pumps***



## **Power-Flo Pumps & Systems**

*a Power-Flo Technologies company*

**General Safety Information**

Before installation, read the following instructions carefully. Failure to follow instruction and Safety information could cause serious bodily injury, death and/or property damage. Each Power-Flo pump is individually factory tested to insure proper performance. Closely following these instructions will eliminate potential operating problems, assuring years of trouble-free service.

**⚠ DANGER** "Danger" indicates an imminent hazardous situation which, if not avoided, WILL result in death or serious injury.

**⚠ WARNING** "Warning" indicates an imminent hazardous situation which, if not avoided, MAY result in death or serious injury.

**⚠ CAUTION** "Caution" indicates a potentially hazardous situation which, if not avoided, MAY result in minor or moderate injury.

**IMPORTANT - Power-Flo Pumps and Systems is not responsible for losses, injury or death resulting from failure to observe these safety precautions, misuse, abuse or misapplication of pumps or equipment.**

 **ALL RETURNED PRODUCTS MUST BE CLEANED, SANITIZED, OR DECONTAMINATED PRIOR TO SHIPMENT, TO INSURE EMPLOYEES WILL NOT BE EXPOSED TO HEALTH HAZARDS IN HANDLING SAID MATERIAL. ALL APPLICABLE LAWS AND REGULATIONS SHALL APPLY.**

**⚠ WARNING** Installation, wiring, and junction connections must be in accordance with the National Electric Code and all applicable state and local codes. Requirements may vary depending on usage and location.

® Power-Flo is a registered trademark of Power-Flo Technologies Inc. Other brand and product names are trademarks or registered trademarks of their respective holders. Alteration Rights Reserved. 1/09, 8/09, 9/09, 3/11, 8/11, 6/13, 1/14, 7/14, 9/2020, 1/2021

**⚠ WARNING** Installation and servicing is to be conducted by qualified personnel only.

**⚠ DANGER** Keep clear of suction and discharge openings. **Do not** insert fingers in pump with power connected.

**⚠ WARNING** Always wear eye protection when working on pumps. Do not wear loose clothing that may become entangled in moving parts

**⚠ DANGER** Pumps build up heat and pressure during operation. Allow time for pumps to cool before handling or servicing.

**⚠ DANGER** This pump is **not** intended for use in swimming pools or water installations where human contact with pumped fluid.

**⚠ DANGER** Risk of electric shock. To reduce risk of electric shock, always disconnect pump from power source before handling. **Lock out power & tag.**

**⚠ WARNING** **Do not** use these pumps in water over 160°F. **Do not** exceed manufactures recommended maximum performance, as this could cause the motor to overheat.

**⚠ DANGER** Operation against a closed discharge valve will cause premature bearing and seal failure. Heat build up on self-priming and end suction pumps may cause dangerous pressures. A high temperature switch or pressure relief valve is recommended to be installed in pump case.

**⚠ WARNING** Carefully read instruction manuals supplied with motor or engine before operating or servicing.

**⚠ DANGER** **DO NOT** pump hazardous material. These pumps are NOT to be installed in locations classified as hazardous in accordance with the National Electric Code, ANSI/NFPA 70.

**⚠ WARNING** Pumps constructed with or fitted with bronze/brass may contain lead levels higher than considered safe for potable water systems. Lead is known to cause cancer and birth defects or other reproductive harm. Various government agencies have determined that leaded copper alloys should not be used in potable water applications.

 **WARNING:** CANCER AND REPRODUCTIVE HARM-  
WWW.P65WARNINGS.CA.GOV

**IMPORTANT!** Prior to installation, record Model Number, MFG Date, and/or serial number, from pump name plate for future reference.

Model:
Serial:
MFG Date:

**Specifications**

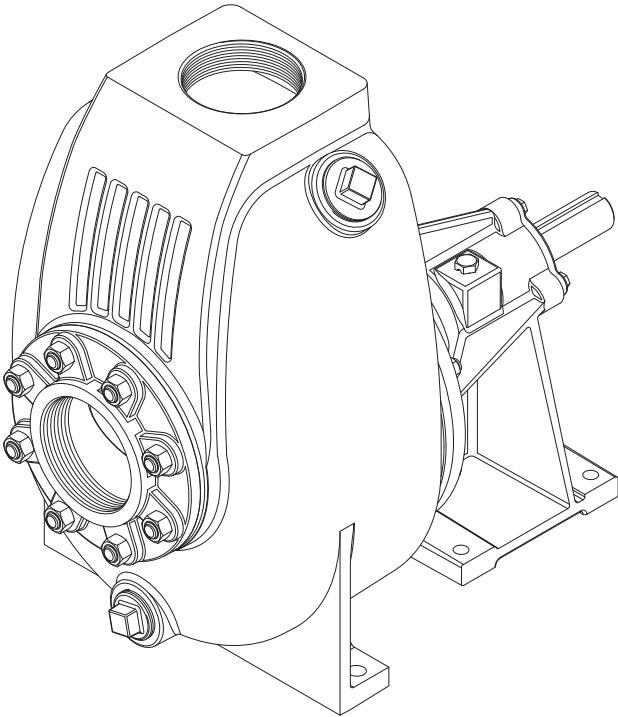

<b>DISCHARGE</b>	4" x 4" NPT, Female
<b>LIQUID TEMPERATURE</b>	160°F Continuous
<b>VOLUTE/WEARPLATE</b>	Cast Iron, ASTM A48, Class 30
<b>SEAL PLATE</b>	Cast Iron, ASTM A48, Class 30
<b>PEDESTAL</b>	Cast Iron, ASTM A48, Class 30
<b>SHAFT</b>	Steel
<b>IMPELLER</b>	Open trash type. Material: Cast Iron, ASTM A48, Class 30
<b>O-RINGS</b>	Buna-N
<b>HARDWARE</b>	Steel
<b>PAINT</b>	Air dry enamel
<b>SEAL</b>	Single Mechanical Self-Lubricating Material: Carbon/Ceramic/Buna-N
<b>PUMP END BEARING</b>	Single Row, Ball, Oil Lubricated
<b>DRIVE END BEARING</b>	Double Row, Ball, Oil Lubricated
<b>CHECK VALVE</b>	Neoprene Flap type valve, with cast iron weight
<b>STAINER</b>	Steel

**Series: PF30MU  
PF40MU**

**4" x 4"**

**Universal Drive/Frame Mtd  
Trash/Solids Handling**



**Dimensions**

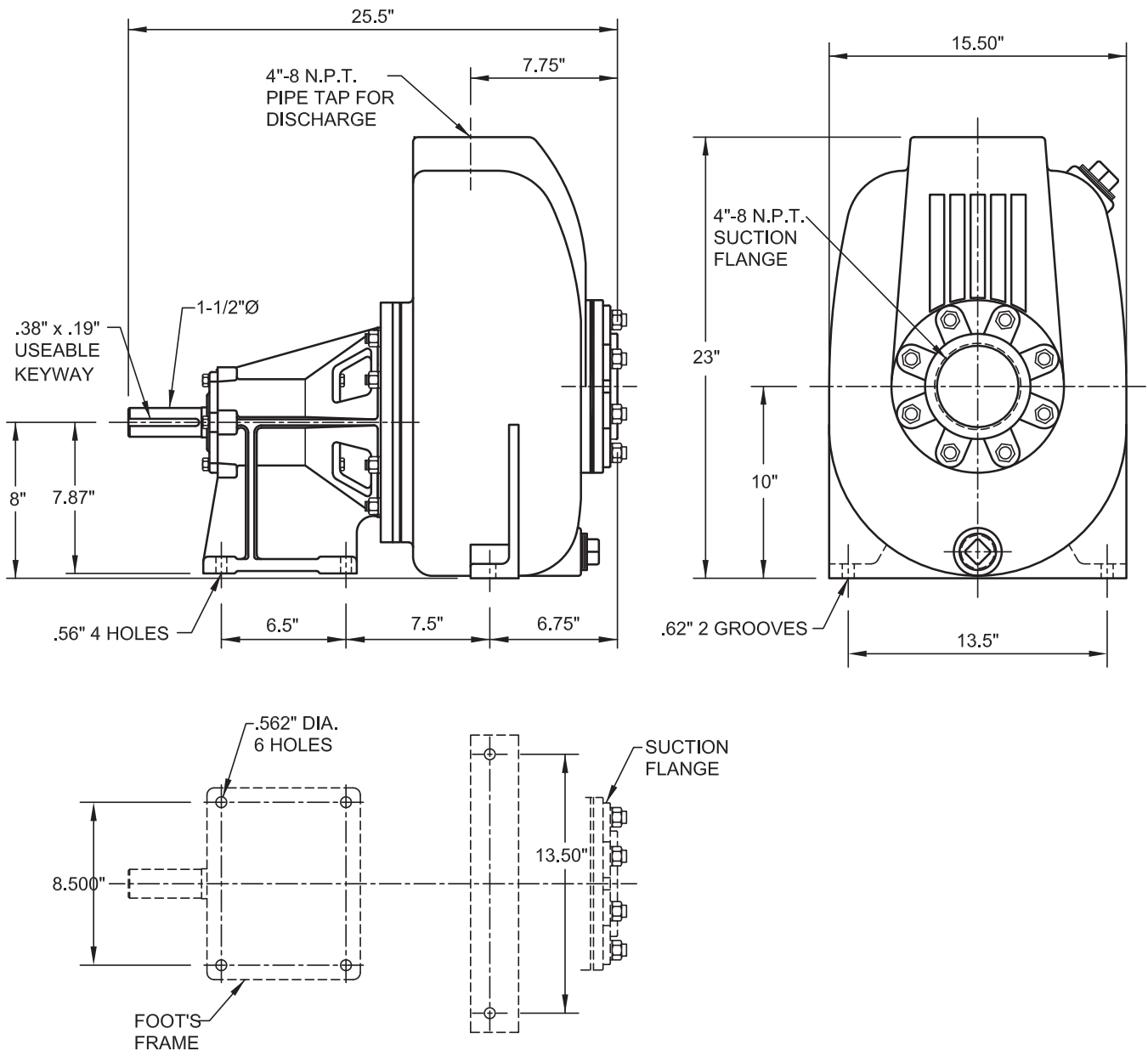

Model	Weight	
PF30MU	330 lbs	
PF40MU	330 lbs	

Not for pumping flammable liquids or hazardous materials that is not compatible with pump materials.

**Performance**



**Power-Flo Pumps & Systems**  
a Power-Flo Technologies company

MODELS: IMP. DIA.  
PF30MU 9.00"

FLOW (GPM) \_\_\_\_\_  
TDH (FT) \_\_\_\_\_

SPEED RPM: Various  
HP: \_\_\_\_\_  
Volts \_\_\_\_\_ Phase \_\_\_\_\_

DISCH. SIZE: 4.0"  
SP. GR. 1.0

ISSUE DATE: 1/09  
CURVE NO. pf30mu

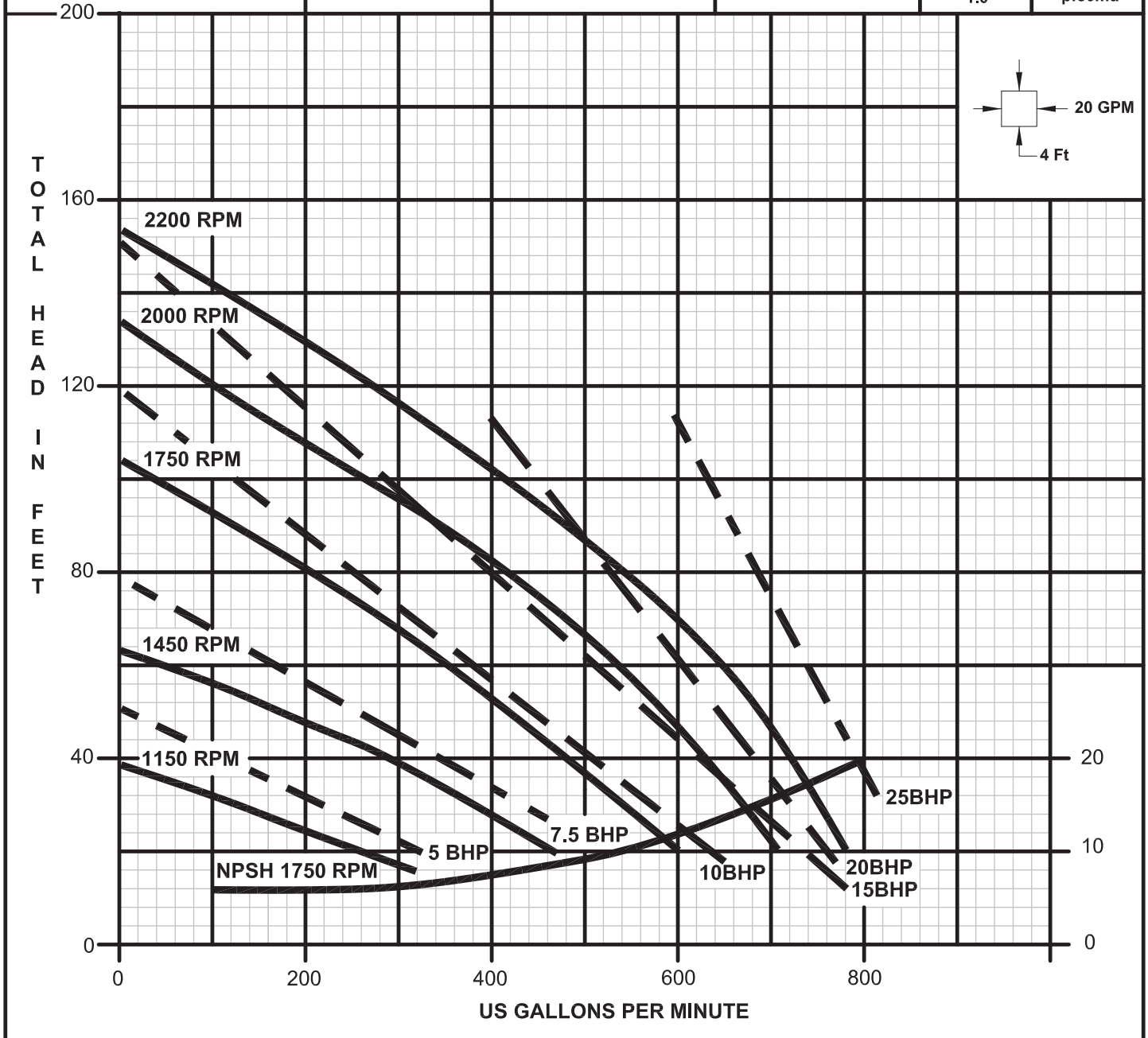

Performance

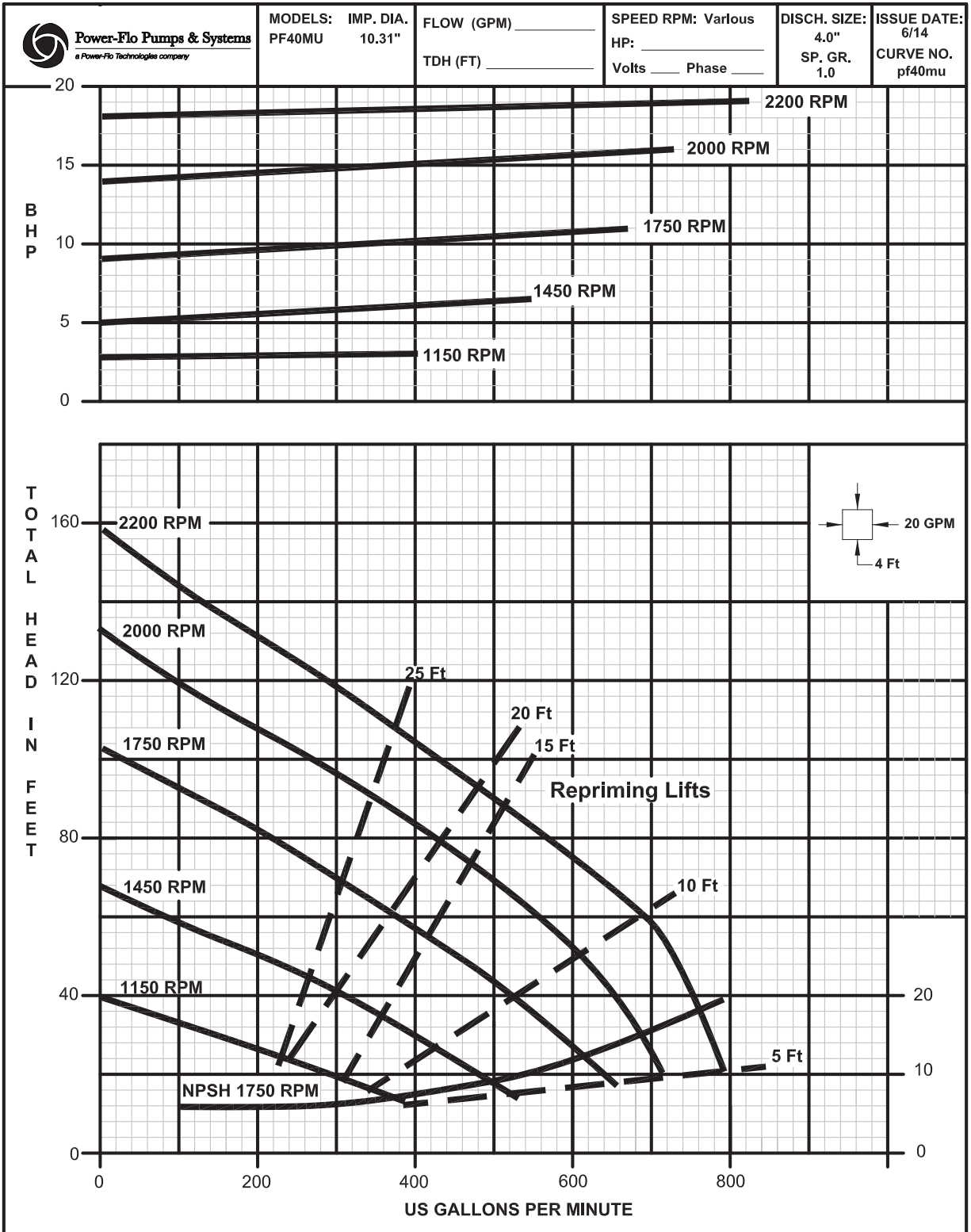

**Receiving, Installation & Service****Receiving Inspection**

Upon receiving the pump, it should be inspected for damage or shortages. If damage has occurred, file a claim immediately with the company that delivered the pump. If the manual is removed from the packaging, do not lose or misplace.

**Storage**

Any product that is stored for a period longer than six (6) months from the date of purchase should be bench tested prior to installation. A bench test consists of, checking the impeller to assure it is free turning and a run test to assure the motor (and switch if provided) operate properly. Do not pump out of liquid.

**Location**

Locate pump as near as possible to the liquid being pumped. Do Not place pump more that 25 feet above the surface of the liquid supply. Be sure pump is level. Mount pump firmly so not to move due to vibration.

Units should be permanently grouted onto a cement foundation. The pumps should be level to provide correct operating conditions. The flexible coupling should be realigned after grouting to eliminate excessive wear on the coupling.

Allow a minimum 18 inches in front of the pump case cover to permit easy removal and access to the interior of the pump. On belt drive units, allow a minimum of 10 inches at the shaft end to permit removal of the pedestal or rotating assembly.

**Controls**

Be sure the electrical specification of the control selected properly match the electrical specifications of the pump.

**Motor Connection**

All wiring of motor and control, overload protection and grounding should be in accordance with the National Electrical Code, State and Local codes. Make motor connection per label located on motor or motor manufactures manual.

**Rotation**

Pump rotation should agree with the direction on the rotation plate. If rotation on 3 phase is incorrect, interchange any two incoming wire leads. Rotation is "clockwise" when looking from the motor end.

The impellers are threaded on the shaft and it is necessary to slide one half of the coupling back when checking rotation in order to eliminate the possibility of unscrewing the impeller and damaging the pump.

**Suction**

**CAUTION! - Pump should not be operated without a suction strainer to prevent foreign matter from being drawn into impeller. The strainer should be cleaned regularly.**

The use of pipe the same size as the port size is highly recommended. Using a smaller pipe line can cause internal damage. Make sure all lines have air-tight joints. The smallest air leak in the suction line may prevent the pump from priming. All horizontal suction lines should slope up to the pump to avoid trapped air pockets.

**Discharge**

Connect discharge hose or pipe to the discharge port. Make sure all lines have air-tight joints.

**Driver**

Refere to Engine or Motor Manufacture's Instructions.

**Lubrication**

The bearing housing is the only part that needs lubricated. The shaft seals and impeller are lubricated by the liquid being pumped and needs no other lubrication.

The bearing housing is filled with 90 weight oil for bearing lubrication. The oil level should be checked periodically. Check oil level by removing the oil dip stick (34) and check the level on it.

**Priming**

Remove pipe plug (31) in top of body (5) and fill the pump body completely with solids free liquid. In freezing weather prime pump with warm water.



**DO NOT operate pump without priming first. Operating dry will damage seal.**

**Starting**

To start pump, apply power to motor or engine per the Motor or Engine manufacture's instructions.

**Shutdown**

Disconnect electric power or stopping engine to shut down. It is recommended to drain and flush pump if pump has been operating in freezing weather.

**Service**

Turn off and lock out power before servicing pump.

**Check Valve**

Disconnect suction piping and remove hex nuts (24), suction flange (2). DO NOT PRY ON FLANGE but bump off with block of wood and a hammer. Remove gasket (30), weights (3) & (4) and screw (25), and replace if worn or damaged.

To replace, the *HINGE* section of gasket (30) is at the *TOP* and the *LARGE* weight is on the pump side of gasket.



**Installation & Service**

**Body & Impeller**

Disconnect suction and discharge piping. To expose body (5), wear plate (11), gaskets (28) & (29) and impeller (6) for clean out or replacement, remove hex nuts (27) then remove body (5) and wear plate (11) from bearing pedestal (1). If impeller (6) needs replacement, unsew from shaft. The impeller has right hand threads, so to break loose use a block of wood against a vane and strike with hammer. To replace wear plate (11), remove screws (21).

**Shaft Seal**

Remove body and impeller. Remove impeller shims (17), (18) and the seal's (14) spring holder, spring and rotating member of seal from shaft (10). Replace if worn or damaged.

If stationary member needs replaced, remove screws (21) and pull seal plate (8) together with stationary from bearing housing (1). Press stationary out of seal plate (8).



**Handle all seal parts with care. Do Not damage lapped faces.**

To reassemble, lightly oil seal cavity in seal plate (8) and ring of stationary member. Replace seal plate (8) onto bearing housing (1). Lightly oil shaft (10) press stationary over shaft and into seal plate (8). Lightly oil shaft and inner surface of bellows of rotating member. With lapped surface facing bearing housing, slide rotating member onto shaft until lapped faces of rotating member and stationary are together. Use a piece of tubing or finger pressure, to press on bellows only, not on the retainer. Driving lugs in retainer should mate into rotating member. Replace spring and spring holder (23) and reassemble remainder of pump.

When impeller (6) is removed, also remove shims (17), (18), spring holder, spring and rotation members of shaft seal (14). To reassemble be sure to use a combination of impeller shims (17) and (18), body gaskets (28) and (29) to result in an impeller-to-body clearance of approximately .015".

**Shaft and Bearing**

Remove cap screws (22), lockwashers (16) and pull front bearing cap (7) with oil seal (15) from bearing pedestal (1). Remove cap screws (22), lockwashers (16) and pull rear bearing cap (7) with oil seal (15) from bearing pedestal (1). Remove bearing shims (19) and (20). Tap on drive end of shaft (10) with a block of wood and a hammer, driving the shaft (10) together with the complete front bearing (13) and the roller and cone of the back bearing (12) out of the pedestal (1). Replace if required.

Press bearings from shaft. If oil seals are to be replaced, press used seals out of bearing caps and replace. Press new seal into bearing caps with patent number side out.

Press double row back bearing (12) onto drive end of shaft (10) seating it snug against the shaft shoulder. Press single row, front bearing (13) onto impeller end of shaft (10) seating it snug against the shaft shoulder.

Place assembled shaft and bearings into pedestal (1) key end first. Bring the front bearing (13) into position and press in place. If tight, use a sleeve and hammer to tap into position. Replace back bearing cap (7) with oil seal (15) using required number of shims (19) and (20). **DO NOT** seat bearings too tight but make sure that a snug fit is insured, yet permitting free movement of shaft in bearings. Replace front bearing cap (7) with oil seal (15) using required number of shims (19) and (20) to allow for a .005" shaft end play. Reassembling remainder of pump.

Refill pedestal with 6.14 oz. of a ISO VG32, lubricating mineral oil suitable for hydraulic systems,

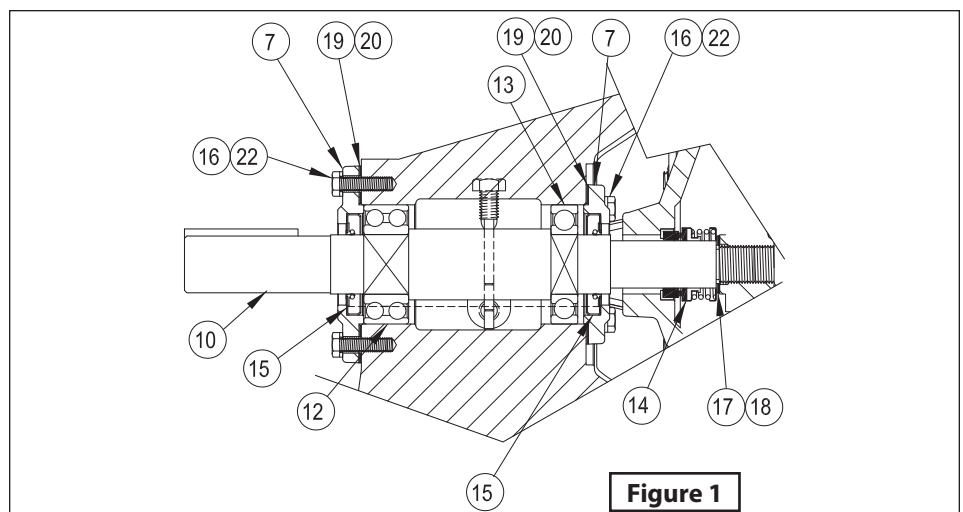



For Repair Part Please supply: Model Number and MFG Date as shown on Name Plate, and Part Description and Part Number as shown on Parts List.

**Repair Parts**

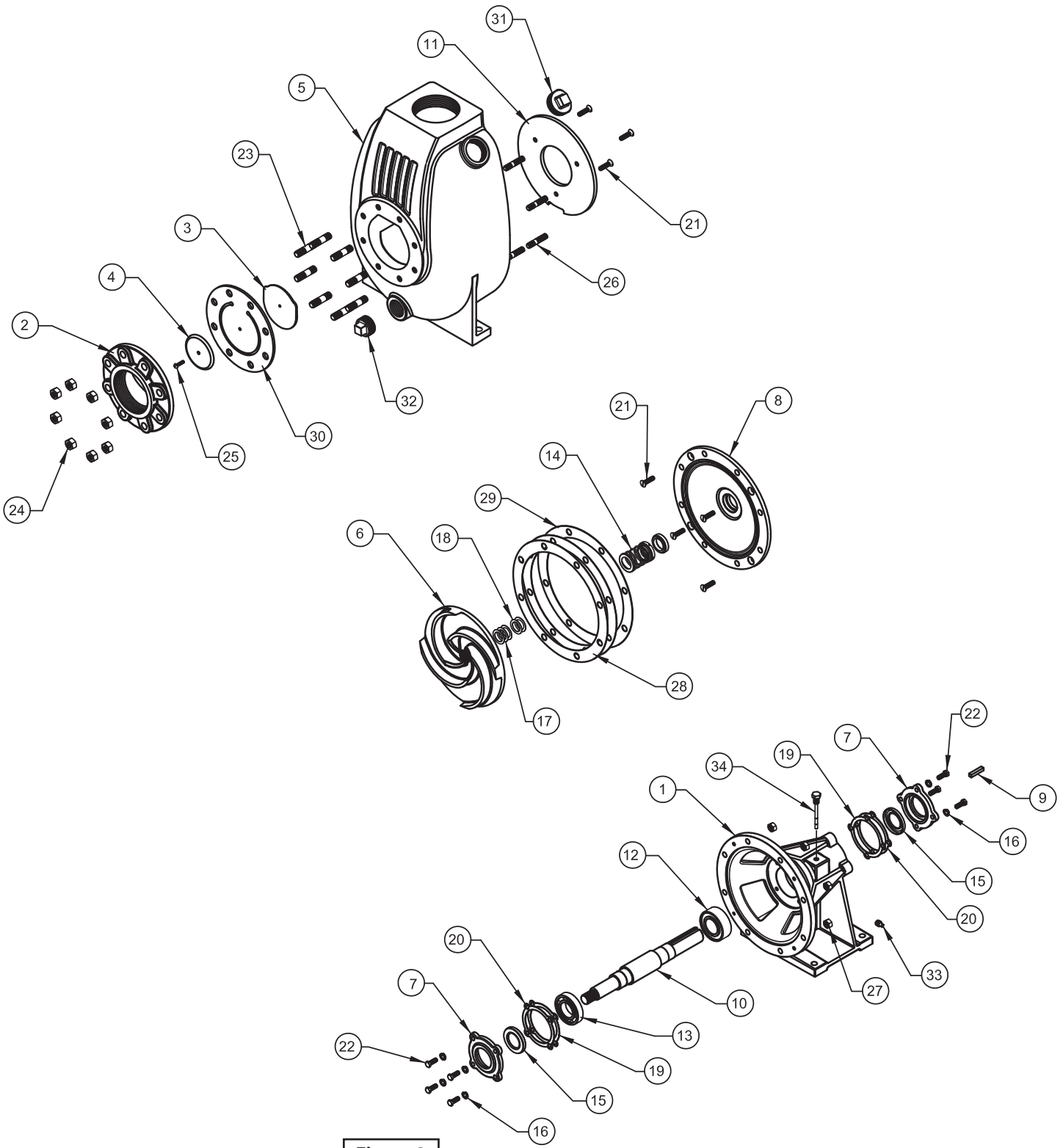

**Figure 2**

**Repair Parts**

For Repair Part Please supply: Model Number and MFG Date as shown on Name Plate, and Part Description and Part Number as shown on Parts List.

ITEM	QTY	DESCRIPTION	PART NUMBER PF30MU	PART NUMBER PF40MU
1	1	Bearing Housing	PF03040005	PF03040005
2	1	Suction Flange	PF03050006	PF03050006
3	1	Weight Large	PF03080003	PF03080003
4	1	Weight Small	PF03080004	PF03080004
5	1	Casing	PF03090007	PF03090007
6	1	Impeller	PF03140007B	PF03140007
7	1	Cap Bearing	PF03170002	PF03170002
8	1	Seal Plate	PF03180014	PF03180014
9	1	Shaft Key 3/8" #5163	PF30400634	PF30400634
10	1	Shaft	PF30400709	PF30400709
11	1	Wear Plate	PF03190005	PF03190005
12	1	Outer Bearing, 3208	PF31020014	PF31020014
13	1	Inner Bearing, 6208	PF31020013	PF31020013
14	1	Shaft Seal 1.25", T21	PF31030131	PF31030131
15	2	Bearing Cap Oil Seal	PF31150002	PF31150002
16	8	Lockwasher 3/8"	◆	◆
17	3	Shims Washer 0.10" #1349	PF91010121	PF91010121
18	2	Shims Washer .031" #1348	PF91010130	PF91010130
19	2	Bearing Cap Shims #5069	PF91010151	PF91010151
20	2	Bearing Cap Shims #5068	PF91010152	PF91010152
21	7	Conic Head Screw 3/8" x 1.50" Lg	◆	◆
22	8	Hex Hd Screw 3/8 x 1" Lg	◆	◆
23	8	Screw 5/8 x 2.50" Lg	◆	◆
24	8	Hex Nut 5/8"	◆	◆
25	1	Screw 1/4" x 1" Lg	◆	◆
26	8	Screw 1/2" x 2.50" Lg	◆	◆
27	8	Hex Nut 1/2"	◆	◆
28	2	Casing Gasket #3188	PF92010148	PF92010148
29	1	Casing Gasket #3189	PF92010149	PF92010149
30	1	Suction Check Valve #1486	PF92010214	PF92010214
31	1	Square Head Plug 2"	◆	◆
32	1	Square Head Plug 1-1/2"	◆	◆
33	1	Square Head Plug 1/4"	◆	◆
34	1	Bayonet	PF30400851	PF30400851

(◆) = Acquire standard hardware locally.

**Trouble Shooting Chart**



**Risk of electric shock. Always disconnect the pump from the power source before handling inspections or repairs.**

Symptom	Possible Cause(s)	Corrective Action
Little or no discharge and will not prime	<ol style="list-style-type: none"> <li>1. Pump body not filled with water</li> <li>2. Total head too high</li> <li>3. Suction head higher than pump designed for</li> <li>4. Impeller partially or completely plugged</li> <li>5. Leak in suction line</li> <li>6. Foot-valve too small</li> <li>7. Impeller damaged</li> <li>8. Foot-valve or suction line not submerged deep enough in water, pulling air</li> <li>9. Insufficient inlet pressure or suction head</li> <li>10. Suction piping too small</li> <li>11. Body gasket leaking</li> <li>12. Suction or discharge line valves closed</li> <li>13. Piping damaged</li> <li>14. Clogged strainer or foot-valve</li> <li>15. Incorrect engine speed</li> </ol>	<ol style="list-style-type: none"> <li>1. Fill pump body with water.</li> <li>2. Shorten suction head</li> <li>3. Lower suction head, install foot-valve and prime</li> <li>4. Disassemble pump and clean out impeller</li> <li>5. Repair or replace suction line</li> <li>6. Match foot-valve size to piping or install one larger size foot-valve</li> <li>7. Disassemble pump and replace impeller</li> <li>8. Submerge lower in water</li> <li>9. Increase inlet pressure by adding more water to tank or increasing back pressure by turning gate valve on discharge line partially closed.</li> <li>10. Increase pipe size to pump inlet size or larger</li> <li>11. Replace</li> <li>12. Open</li> <li>13. Clean or replace</li> <li>14. Clean or replace</li> <li>15. Increase speed</li> </ol>
Loss of suction after satisfactory operation	<ol style="list-style-type: none"> <li>1. Air leak in suction line</li> <li>2. When pump was last turned off, water siphoned out of pump body</li> <li>3. Suction head higher than pump designed for</li> <li>4. Insufficient inlet pressure or suction head</li> <li>5. Clogged foot-valve, strainer or pump</li> <li>6. Defective wearplate</li> </ol>	<ol style="list-style-type: none"> <li>1. Repaire or replace suction line</li> <li>2. Refill (reprime) pump body before restarting</li> <li>3. Lower suction head, install foot-valve and prime</li> <li>4. Increase inlet pressure by adding more water to tank or increasing back pressure by turning gate valve on discharge line to partially closed.</li> <li>5. Unclog or replace</li> <li>6. Replace</li> </ol>
Pump overloads driver	<ol style="list-style-type: none"> <li>1. Total head lower than pump rating, unit delivering too much water</li> <li>2. Specific gravity and viscosity of liquid being pumped different than the pump rating</li> <li>3. Speed to high</li> </ol>	<ol style="list-style-type: none"> <li>1. Increase back pressure by turning gate valve on discharge line to partially closed position that will not overload motor.</li> <li>2. Consult factory</li> <li>3. Check and correct speed</li> </ol>
Pump vibrates and/or makes excessive noise	<ol style="list-style-type: none"> <li>1. Mounting plate or foundation not rigid enough</li> <li>2. Foreign material in pump causing unbalance</li> <li>3. Impeller bent</li> <li>4. Cavitation present</li> <li>5. Piping not supported to relieve any strain on pump assembly</li> </ol>	<ol style="list-style-type: none"> <li>1. Reinforce</li> <li>2. Disassemble pump and remove</li> <li>3. Replace impeller</li> <li>4. Check suction line for proper size and check valve in suction line if completely open, remove any sharp bends before pump and shorten suction line</li> <li>5. Make necessary adjustments</li> </ol>
Pump runs but no fluid	<ol style="list-style-type: none"> <li>1. Air leak in suction piping</li> <li>2. Pump located too far from fluid source</li> <li>3. Gate valve closed</li> <li>4. Clogged strainer</li> <li>5. Fouled foot-valve</li> <li>6. Discharge height too great</li> <li>7. Fouled impeller</li> <li>8. Faulty mechanical seal</li> </ol>	<ol style="list-style-type: none"> <li>1. Replace</li> <li>2. Replace</li> <li>3. Open</li> <li>4. Clean or Replace</li> <li>5. Clean or Replace</li> <li>6. Lower the height</li> <li>7. Clean or Replace</li> <li>8. Replace</li> </ol>
Pump leaks at shaft	<ol style="list-style-type: none"> <li>1. Worn mechanical seal</li> <li>2. Seal not installed properly</li> </ol>	<ol style="list-style-type: none"> <li>1. Replace</li> <li>2. Follow service instructions for installing seal</li> </ol>

**NOTE:** Power-Flo Pumps & Systems assumes no responsibility for damage or injury due to disassembly in the field. Disassembly of the pumps or supplied accessories other than at Power-Flo Pumps & Systems or its authorized service centers, automatically voids warranty.



## LIMITED WARRANTY

Manufacturer warrants, to the immediate purchaser and subsequent initial owner during the warranty period, every new pump to be free from defects in material and workmanship under normal use and service, when properly used and maintained, for a period of eighteen (18) months from date of manufacture or twelve (12) months from date of installation (which ever comes first). Failure due to wear due to excessive abrasives is not covered. The initial owner is the purchaser who first uses the pump after its initial installation, or for non-permanent installation, the first owner who uses the pump. The date of installation shall be determined by a dated sales receipt noting the model and serial number of the pump. The dated sales receipt must accompany the returned pump. Product will be repaired, replaced or remanufactured at Manufacturer's option. No allowance will be made for shipping charges, damages, labor or other charges that may occur due to product failure, repair or replacement. This warranty does not apply to and there shall be no warranty for any material or product that has been disassembled without prior approval of Manufacturer, subjected to misuse, misapplication, neglect, alteration, accident or act of God; that has not been installed, operated or maintained in accordance with Manufacturer's installation instructions; that has been exposed to outside substances including but not limited to the following: sand, gravel, cement, mud, tar, hydrocarbons, hydrocarbon derivatives (oil, gasoline, solvents, etc.), or other abrasive or corrosive substances, wash towels or feminine sanitary products, etc. in all pumping applications. The warranty set out in the paragraph above is in lieu of all other warranties expressed or implied; and we do not authorize any representative or other person to assume for us any other liability in connection with our products. Contact Manufacturer at: 1-877-24PUMPS or [www.powerflopumps.com](http://www.powerflopumps.com), Attention: Customer Service Department, to obtain any needed repair or replacement of part(s) or additional information pertaining to our warranty.

**MANUFACTURER EXPRESSLY DISCLAIMS LIABILITY FOR SPECIAL, CONSEQUENTIAL OR INCIDENTAL DAMAGES OR BREACH OF EXPRESSED OR IMPLIED WARRANTY; AND ANY IMPLIED WARRANTY OF FITNESS FOR A PARTICULAR PURPOSE AND OF MERCHANTABILITY SHALL BE LIMITED TO THE DURATION OF THE EXPRESSED WARRANTY.**

Some states do not allow limitations on the duration of an implied warranty, so the above limitation may not apply to you. Some states do not allow the exclusion or limitation of incidental or consequential damages, so the above limitation or exclusion may not apply to you. This warranty gives you specific legal rights and you may also have other rights which vary from state to state.

