

**Model: PFACE**

### Features:

General purpose utility pump for residential use to water lawns, pump out flooded basements, boost city water pressure, bail out boats.

- **DISCHARGE:** 3/4" Hose Thread
- **LIQUID TEMPERATURE:** 104°F
- **MOTOR HOUSING:** Thermoplastic
- **VOLUTE:** Cast Iron
- **IMPELLER:** 3 Vane, Open type, Thermoplastic
- **SHAFT:** Steel
- **O-RINGS:** Buna-N
- **SEAL:** Single Mechanical, Carbon/Ceramic/Buna-N
- **POWER CORD:** SJT, 10Ft. with plug.
- **MOTOR:** Single phase, Air Filled, Class B Insulation, Thermal Protected



**Utility Pump  
3/4" Inlet/Outlet,  
Garden Hose Connection**

MODEL	HP	Hz	Volts/Ph	RPM	Full Load Amps	Weight
PFACE	1/2	60	115/1	7000	9.0	17 lbs

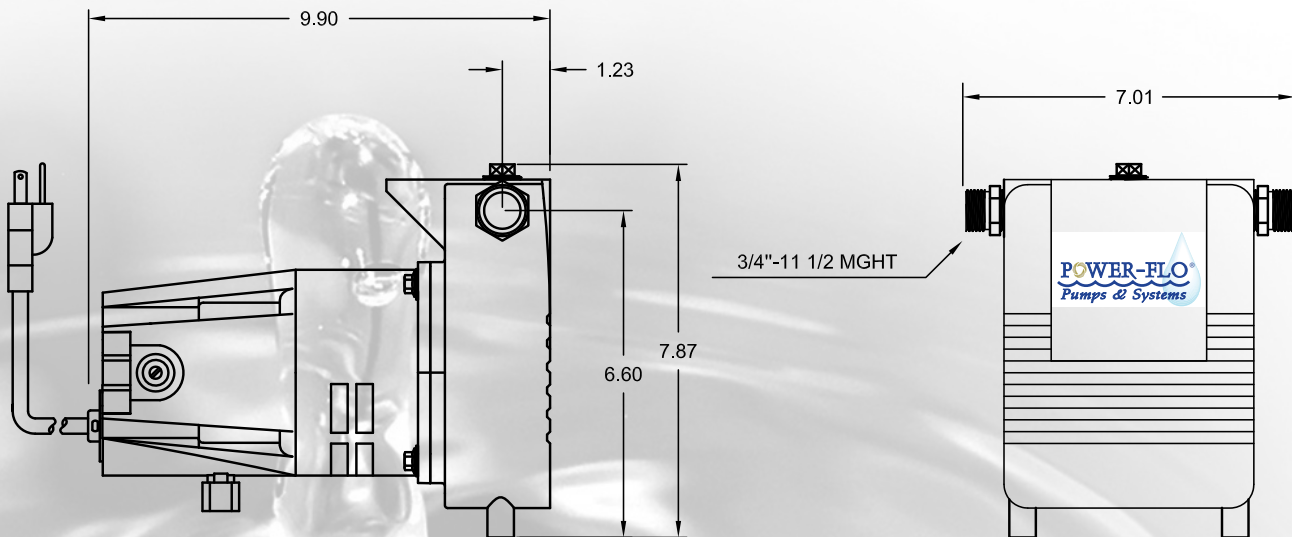

**Sump & Utility Pumps - 1/2HP - 7000RPM - 60Hz**

Model: PFACE

**Sump & Utility Pumps - 1/2HP - 7000RPM - 60HZ**

