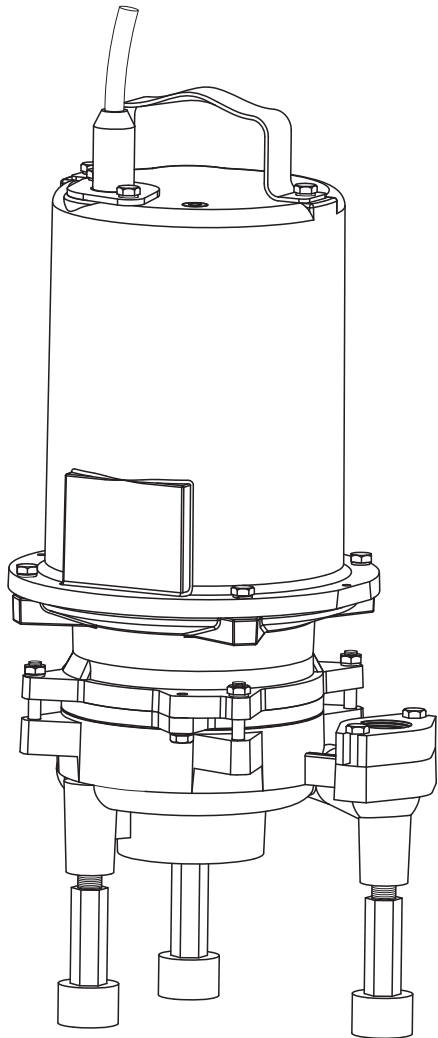


# POWER-FLO

*Pumps & Systems*



**Series:**

**PFG2002HV & HH**  
**PFG2022HV & HH**  
**PFG2062HV & HH**  
**PFG2032HV & HH**  
**PFG2042HV & HH**

**Double Seal**

**2 HP • 3450 RPM • 60 Hz**  
**Submersible Grinder Pump**

**General Safety Information**

Before installation, read the following instructions carefully. Failure to follow instruction and Safety information could cause serious bodily injury, death and/or property damage. Each Power-Flo pump is individually factory tested to insure proper performance. Closely following these instructions will eliminate potential operating problems, assuring years of trouble-free service.

**▲ DANGER** "Danger" indicates a hazardous situation which, if not avoided, WILL result in death or serious injury.

**▲ WARNING** "Warning" indicates a hazardous situation which, if not avoided, MAY result in death or serious injury.

**▲ CAUTION** "Caution" indicates a hazardous situation which, if not avoided, MAY result in minor or moderate injury.

**IMPORTANT - Power-Flo Pumps and Systems is not responsible for losses, injury or death resulting from failure to observe these safety precautions, misuse, abuse or misapplication of pumps or equipment.**

**▲ DANGER** All returned Products must be Cleaned, sanitized, Or decontaminated Prior to shipment, to insure employees will not be exposed to health hazards in handling said material. All applicable laws and regulations shall apply.

**▲ WARNING** Bronze/brass fitted pumps may contain levels higher than considered safe for potable water systems. Government agencies have determined that leaded copper alloys should not be used in potable water applications.

**▲ WARNING** Installation, wiring, and junction connections must be in accordance with the National Electric Code and all applicable state and local codes. Requirements may vary depending on usage and location.

**▲ WARNING** Installation and servicing is to be conducted by qualified personnel only.

**▲ DANGER** Rotating machinery, Amputation or severe lacerations can result. Keep clear of suction and discharge openings. Do not insert fingers in pump with power connected.

**▲ WARNING** Always wear eye protection when working on pumps. Do not wear loose clothing that may become entangled in moving parts.

**▲ DANGER** Pumps build up heat and pressure during operation. Allow time for pumps to cool before handling or servicing.

**▲ DANGER** Hazardous Voltage can Shock, burn or cause death. This pump is not intended for use in swimming pools or water installations where human contact with pumped fluid. Pumps when used as a decorative water fountain pump MUST be used in circuit protected by a Ground Fault Interrupter.

**▲ DANGER** Risk of electric shock. To reduce risk of electric shock, always disconnect pump from power source before handling. Lock out power & tag.

**▲ WARNING** Do not use these pumps in water over 140°F. Do not exceed manufactures recommended maximum performance, as this could cause the motor to overheat.

**▲ DANGER** Do not lift, carry or hang pump by the electrical cables. Damage to the electrical cables can cause shock, burnes or death. Never handle connected power cords with wet hands. Use appropriate lifting device.

**▲ WARNING** Sump and sewage pumps often handle materials which could cause illness or disease. wear adequate protective clothing when working on a used pump or piping. Never enter a basin after it has been used.

**▲ DANGER** Failure to permanently ground the pump, motor and controls before connecting to power can cause shock, burns or death.

**▲ DANGER** These pumps are NOT to be installed in locations classified as hazardous in accordance with the National Electric Code, ANSI/NFPA 70.

**▲ WARNING** DO NOT introduced into any sewer, either directly, or through a kitchen waste disposal unit or toilet: Seafood Shells, Aquarium Gravel, Cat Litter, Plastic Objects (toys, utensils, etc.), Sanitary Napkins or Tampons, Diapers, Rags, Disposable Wipes or Cloth, Medications, Flammable Material, Oil or Grease, Strong Chemicals, Gasoline.

**IMPORTANT!** Prior to installation, record Model Number, MFG Date, Amps, Voltage, Phase and HP, from pump name plate for future reference. Also record the Voltage and Current Readings at Startup:

1 Phase Models	
Amps:	Volts:
3 Phase Models	
Amps L1-2:	Volts L1-2:
Amps L2-3:	Volts L2-3:
Amps L3-1:	Volts L3-1:

Model Number: \_\_\_\_\_

MFG Date: \_\_\_\_\_

PHASE: \_\_\_\_\_ HP: \_\_\_\_\_



© Power-Flo is a registered trademark of Power-Flo Technologies Inc. Other brand and product names are trademarks or registered trademarks of their respective holders. Alteration Rights Reserved. 11/2007 - 3/08, 9/08, 6/09, 9/09, 4/10, 5/10, 3/11, 5/13, 8/13

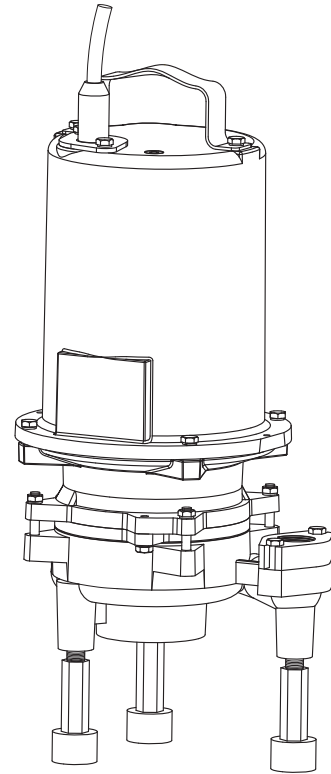
<b>DISCHARGE</b>	1-1/4" NPT Vertical, Bolt-on Flange
<b>LIQUID TEMPERATURE</b>	160°F Intermittent
<b>VOLUTE</b>	Cast Iron, Class 30
<b>MOTOR HOUSING</b>	Cast Iron, Class 30
<b>SEAL PLATE</b>	Cast Iron, Class 30
<b>IMPELLER</b>	12 Vane, Vortex, Bronze
<b>SHREDDING RING</b>	Stainless Steel
<b>CUTTER</b>	Stainless Steel
<b>SHAFT</b>	Stainless Steel
<b>SQUARE RINGS</b>	Buna-N
<b>HARDWARE</b>	Stainless Steel
<b>PAINT</b>	Powder Coated - Industrial Grade
<b>SEAL</b>	Tandem Double Mechanical, Carbon/Ceramic/Buna-N
<b>UPPER BEARING</b>	Single row, Ball, Oil Lubricated
<b>INTERMEDIATE BEARING</b>	Single row, Ball, Oil Lubricated
<b>LOWER BEARING</b>	Sleeve, Oil Lubricated
<b>POWER CORD</b>	<i>PFG Series:</i> 20 ft. Custom Molded, Fast Disconnect, for Sealing and Strain Relief. CSA approved, 12/4 Type SOW
<b>MOTOR</b>	Oil Filled, Squirrel Cage Induction, Class B Insulation
<b>SINGLE PHASE</b>	Capacitor Start/Capacitor Run. Includes overload protection in the motor; Trip Off Temp. 293°F (145°C). <b>Requires starter or control panel which includes capacitors.</b>
<b>THREE PHASE</b>	Dual Voltage 230/460.

NOTE: Consult factory before making modifications as they may effect CSA listing.

**Description**

Designed to reduce domestic, commercial, institutional and light industrial sewage to a finely ground slurry.

**Specifications**



**Series: PFG2002HV & HH  
 PFG2022HV & HH  
 PFG2062HV & HH  
 PFG2032HV & HH  
 PFG2042HV & HH**

**2 HP • 3450 RPM • 60 Hz  
 Submersible Grinder Pump**



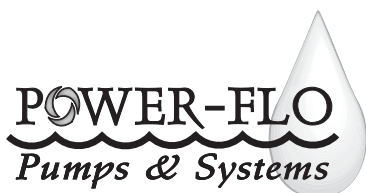
**Specifications**

MODEL	HP	Hz	Volts/ Ph	RPM	Full Load Amps	Locked Rotor Amps	Winding Resistance MAIN -- START	NEMA Start Code	Cord Type	Cord Size	Cord O.D.
<b>High Volume</b>											
PFG2002HV*	2	60	200/1	3450	17.0	53.0	1.75 -- 6.35	F	SOW	12/4	.67
PFG2022HV*	2	60	230/1	3450	15.0	53.8	1.9 -- 1.9	H	SOW	12/4	.67
PFG2062HV	2	60	200/3	3450	11.0	42.0	1.02 -- 1.04 -- 1.03	J	SOW	12/4	.67
PFG2032HV	2	60	230/3	3450	9.0	36.0	1.53 -- 3.07	J	SOW	12/4	.67
PFG2042HV	2	60	460/3	3450	4.0	18.0	1.45 -- 2.90	J	SOW	12/4	.67
<b>High Head</b>											
PFG2002HH*	2	60	200/1	3450	17.0	53.0	1.75 -- 6.35	F	SOW	12/4	.67
PFG2022HH*	2	60	230/1	3450	15.0	53.8	1.9 -- 1.9	H	SOW	12/4	.67
PFG2062HH	2	60	200/3	3450	11.0	42.0	1.02 -- 1.04 -- 1.03	J	SOW	12/4	.67
PFG2032HH	2	60	230/3	3450	9.0	36.0	1.53 -- 3.07	J	SOW	12/4	.67
PFG2042HH	2	60	460/3	3450	4.0	18.0	1.45 -- 2.90	J	SOW	12/4	.67

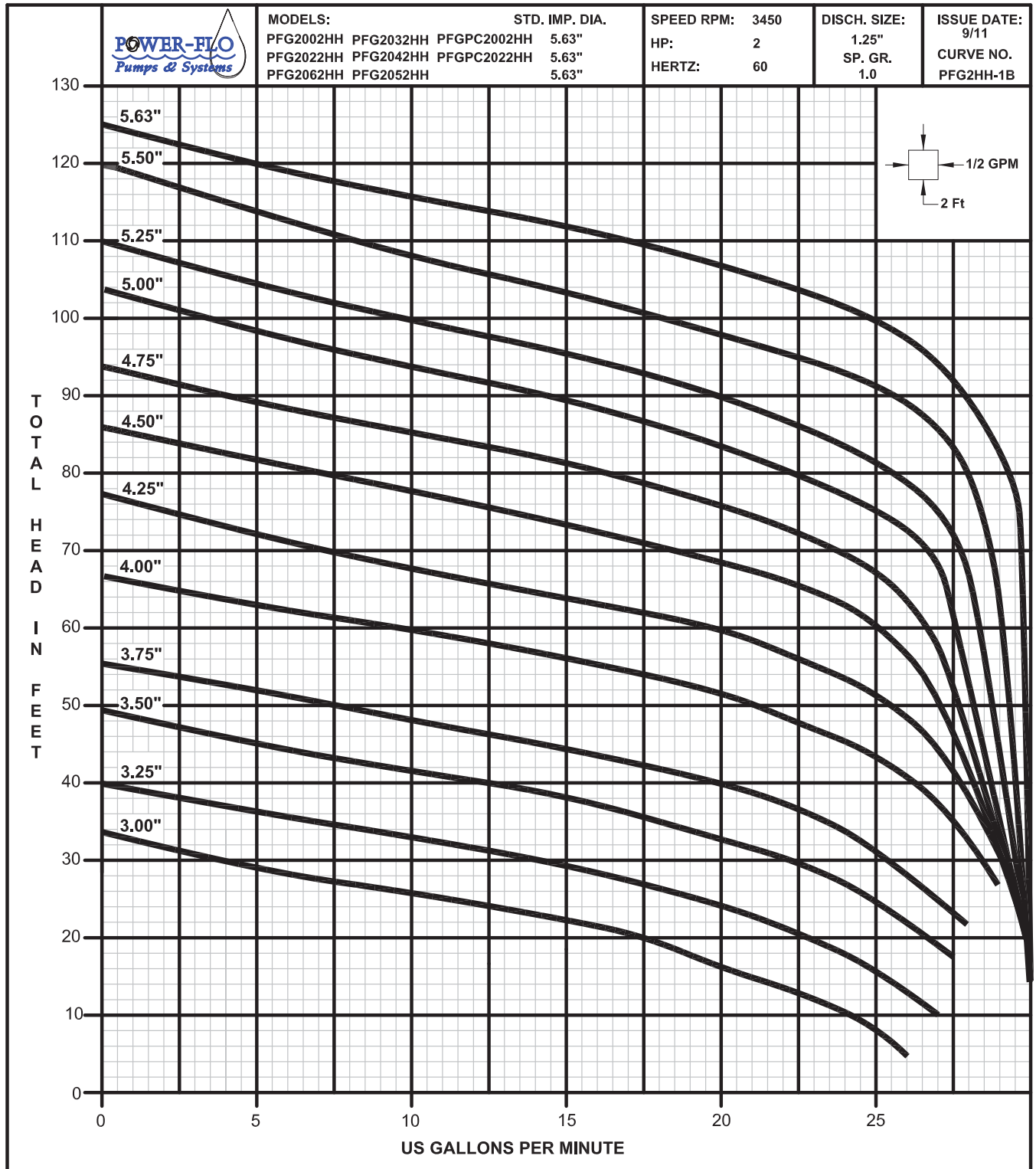
(\* **IMPORTANT!** - These pumps require a control panel with start, run capacitors and relay. Capacitor kits which include Start & Run capacitors and Start relay, are available if a Power-Flo control panel is not used. See page 13 for wiring schematic.  
 PF88243 - for 200 volt, 1 phase  
 PF73306 - for 230 volt, 1 phase

MODEL	HP	Volts/Ph	BREAKER SIZE	HEATER SIZE (**)	VOLTAGE RELAY	START CAPACITOR	RUN CAPACITOR
<b>High Volume</b>							
PFG2002HV	2	200/1	30 Amp	K-60	MARS 169	150 mfd - 250 volts	20 mfd - 450 volts
PFG2022HV	2	230/1	30 Amp	K-57	MARS 169	150 mfd - 250 volts	45 mfd - 450 volts
PFG2062HV	2	200/3	20 Amp	K-53	N/R	N/R	N/R
PFG2032HV	2	230/3	20 Amp	K-50	N/R	N/R	N/R
PFG2042HV	2	460/3	15 Amp	K-33	N/R	N/R	N/R
<b>High Head</b>							
PFG2002HH	2	200/1	30 Amp	K-60	MARS 169	150 mfd - 250 volts	20 mfd - 450 volts
PFG2022HH	2	230/1	30 Amp	K-57	MARS 169	150 mfd - 250 volts	43 mfd - 450 volts
PFG2062HH	2	200/3	20 Amp	K-53	N/R	N/R	N/R
PFG2032HH	2	230/3	20 Amp	K-50	N/R	N/R	N/R
PFG2042HH	2	460/3	15 Amp	K-33	N/R	N/R	N/R

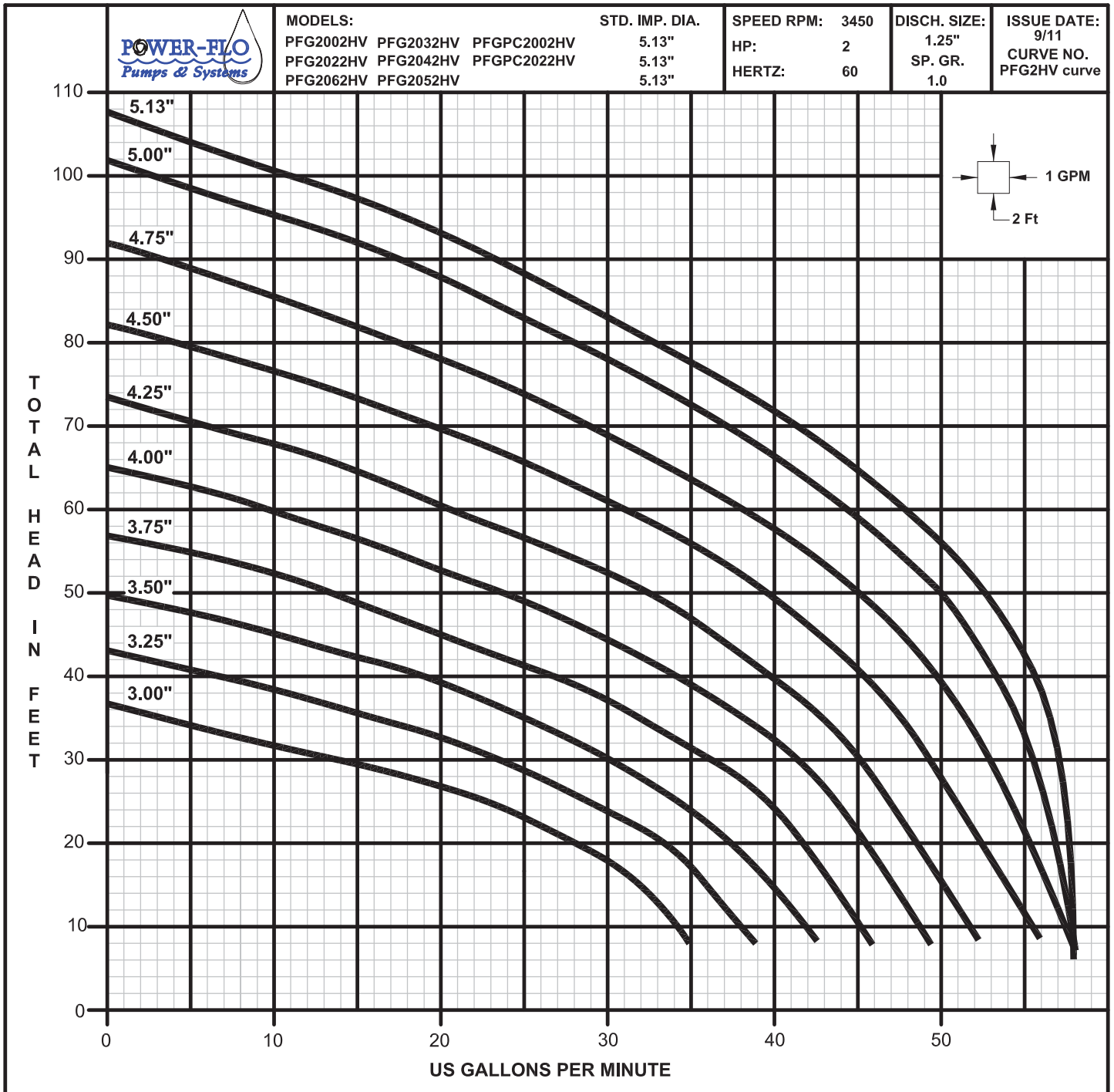
N/R = Not Required  
 Winding resistance ± 5% at terminal block. Rated operation at ± 10% voltage at motor.  
 (\*\*) Recommended heater sizes may vary depending on pump station requirements.

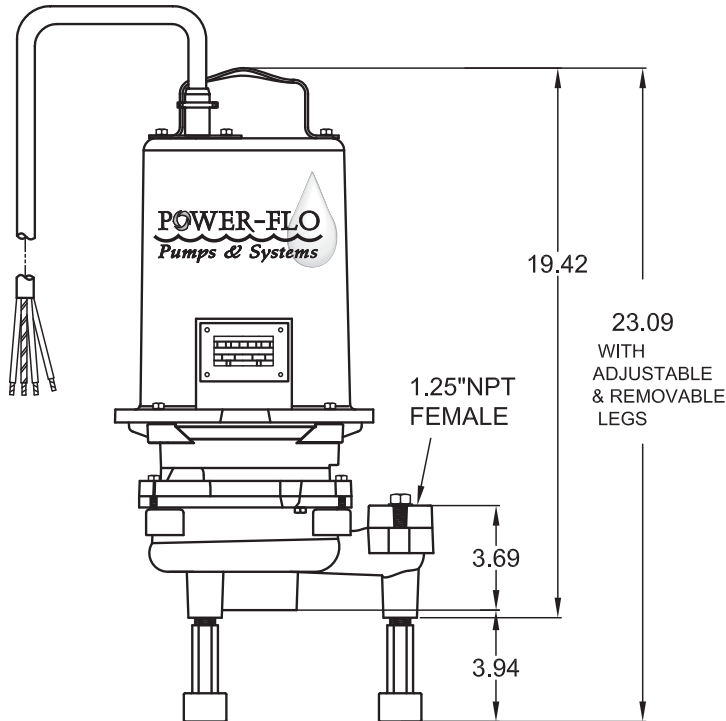


**Performance**



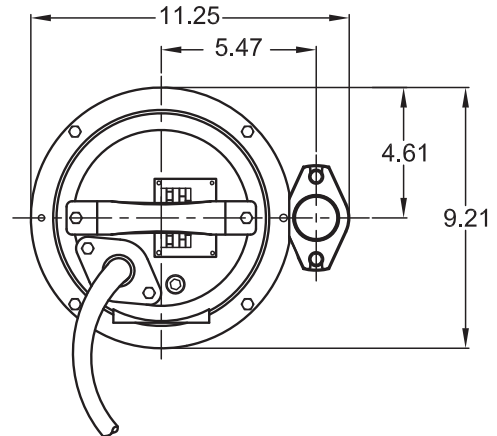
**Performance**





**Dimensions**

**IMPORTANT!** - Pump Suction **MUST** be a minimum of 4" from basin floor with use of legs, stand or slide rail system.



**Receiving & Installation**

**Receiving Inspection**

Upon receiving the pump, it should be inspected for damage or shortages. If damage has occurred, file a claim immediately with the company that delivered the pump. If the manual is removed from the packaging, do not lose or misplace.

**Storage**

Any product that is stored for a period longer than six (6) months from the date of purchase should be bench tested prior to installation. A bench test consists of, checking the impeller to assure it is free turning and a run test to assure the motor (and switch if provided) operate properly. Do not pump out of liquid.

**Controls**

PFG series grinders require a separate approved pump control device or panel for automatic operation. Be sure the electrical specification of the control selected properly match the electrical specifications of the pump.

**Location**

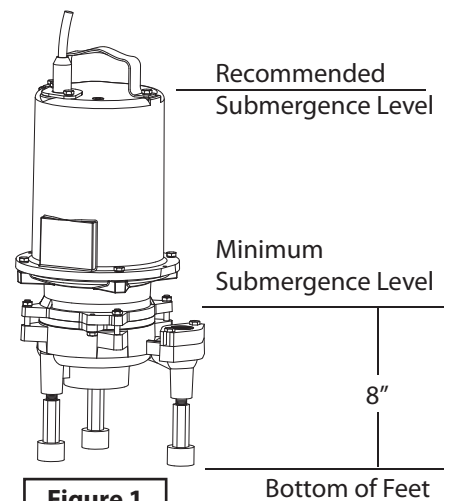
The grinder pump is designed to fit in basin or wetwell by using a slide rail system (with legs removed) or by resting on floor of basin with legs attached.



**IMPORTANT! - A CLEARANCE UNDER THE PUMP FOR ENTRANCE OF SEWAGE SOLIDS MUST BE A MINIMUM OF 3 INCHES TO A MAXIMUM OF 4.5 INCHES.**

**Submergence**

The pump should always be operated in the submerged condition. The minimum sump liquid level should never be less than above the pump's volute (See Figure 1).



**Figure 1**

**Receiving & Installation**

**Installation**

There are several methods of installing grinder pumps. See contract plans and/or specification: A slide rail in a package system or concrete wet well is the most common, which allows the pump(s) to be installed or removed without requiring personnel to enter the wet well.

The sump or basin shall be sealed and vented in accordance with local plumbing codes. **This pump is designed to pump grinder or wastewater, nonexplosive and noncorrosive liquids and shall NOT be installed in locations classified as hazardous in accordance with the National Electrical Code (NEC) ANSI/NFPA 70 or Canadian Electric Code (CEC).** The pump should never be installed in a trench, ditch, or hole with a dirt bottom. The legs will sink into the dirt and the suction will become plugged. The installation should be at a sufficient depth to ensure that all plumbing is below the frost line. If this is not feasible, remove the check valve and size the basin to accommodate the additional backflow volume.

**Discharge Piping**

Discharge piping should be as short as possible and sized no smaller than the pump discharge. **Do not reduce the discharge pipe size below that which is provided on the pump.** Both a check valve and a shut-off valve are recommended for each pump. The check valve is used to prevent backflow into the sump. The shut-off valve is used to manually stop system flow during pump servicing.

**Liquid Level Controls**

The level control(s) should be mounted on the discharge piping, a cable rack or float pole. The level control should have adequate clearance so it cannot hang up in it's swing and that the pump is completely submerged when the level control is in the "Off" mode. By adjusting the cord tether the control level can be changed. One cycle of operation should be observed, so that any potential problems can be corrected.

It is recommended that the level control float should be set to insure that the liquid in the sump never drops below the top of the motor housing or a minimum level of 10 inches above the basin floor.

**Electrical Connections**

**Power cable** - The power cable mounted to the pump must not be modified in any way except for shortening to a specific application. Any splice between the pump and the control panel must be made in accordance with the electric codes. It is recommended that a junction box, if used, be mounted outside the sump or be of at a minimum Nema 4 construction if located within the wet well. **DO NOT USE THE POWER CABLE TO LIFT PUMP.**

Always rely upon a Certified Electrician for installation.

**Thermal Protection:**

The normally closed (N/C) over temperature sensor is embedded in the motor windings and will detect excessive heat in the event an overload condition occurs. The thermal sensor will trip when the windings become too hot and will automatically reset when the pump motor cools to a safe temperature.

It is recommended that the thermal sensor be connected in series to an alarm device to alert that an overtemperature condition and/or motor starter coil to stop pump.

In the event of an overtemperature, the source of this condition should be determined and repaired immediately. Thermal protection shall not be used as a motor overload device. A separate motor overload device must be provided in accordance with NEC code.



**WARNING! - DO NOT LET THE PUMP CYCLE OR RUN IF AN OVERLOAD CONDITION OCCURS !**

If current through the temperature sensor exceeds the values listed, an intermediate control circuit relay must be used to reduce the current or the sensor will not work properly.

TEMPERATURE SENSOR ELECTRICAL RATINGS		
Volts	Continuous Amperes	Inrush Amperes
110-120	3.00	30.0
220-240	1.50	15.0
440-480	0.75	7.5
600	0.60	6.0

**Wire Size:**

If longer power cable is required consult a qualified electrician for proper wire size.





**Installation & Service**

**Pre-Operation**

1. **Check Voltage and Phase**  
Compare the voltage and phase information stamped on the pump name plate.
2. **Check Pump Rotation** - Improper motor rotation can result in poor pump performance and can damage the motor and/or pump. Check rotation on three phase units by momentarily applying power and observe the "kickback".

Kickback should always be in a counter-clockwise direction as viewed from motor end or opposite to impeller rotation. Incorrect rotation for Single-Phase pumps is unlikely. If the rotation is incorrect contact factory.

3. **Name Plate** - Record the information from the pump name plate to drawing in front of manual for future reference.
4. **Insulation Test** - An insulation (megger) test should be performed on the motor. Before the pump is put into service. The resistance values (ohms) as well as the voltage (volts) and current (amps) should be recorded.
5. **Pump-Down Test** - Be sure pump has been properly wired, lowered into the basin, sump or lift station, check the system by filling with liquid and allowing the pump to operate through its pumping cycle. The time needed to empty the system, or pump-down time along with the volume of water, should be recorded.

**Maintenance**

No lubrication or maintenance is required. Perform the following checks when pump is removed from operation or when pump performance deteriorates:

- a). Inspect motor chamber for oil level and contamination.
- b). Inspect impeller and body for excessive build-up or clogging.
- c). Inspect motor and bearings.
- d). Inspect seal for wear or leakage.

**Servicing**

NOTE: Item numbers in ( ) refer to Figures 8 & 9.

**Cooling Oil** - Anytime the pump is removed from operation, the cooling oil in the motor housing should be checked visually for oil level and contamination. To check oil, set unit upright. Remove pipe plug (4) from housing (15). With a flashlight, visually inspect the oil in the housing (15) to make sure it is clean and clear, light amber in color and free from suspended particles. Milky white oil indicates the presence of water. Oil level should be just above the motor when pump is in vertical position.

**Oil Testing**

- Drain oil into a clean, dry container by placing pump on it's side, remove pipe plug (5), from housing (15).
- Check oil for contamination using an oil tester with a range to 30 Kilovolts breakdown.
- If oil is found to be clean and uncontaminated (measuring above 15 KV. breakdown), refill the housing.
- If oil is found to be dirty or contaminated (or measures below 15 KV. breakdown), the pump must be carefully inspected for leaks at the shaft seal, cable assembly, square ring and pipe plug, before refilling with oil. Tolocate the leak, perform a pressure test.

After leak is repaired, dispose of old oil properly, and refill with new oil.

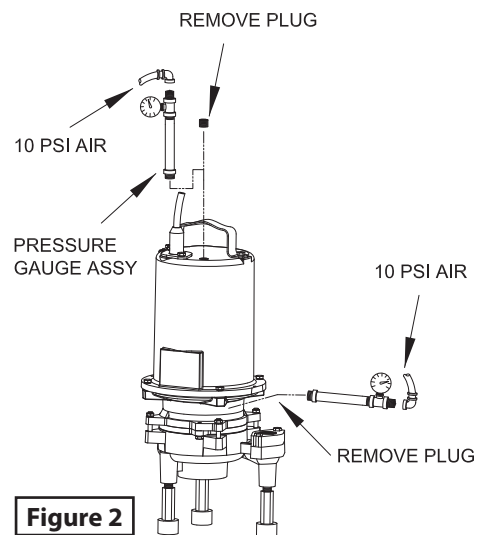
**Pressure Test (If oil has been drained)**

Remove pipe plug (4) from housing (15). Apply pipe sealant to pressure gauge assembly and tighten into hole. Pressurize motor housing to 10 P.S.I. Use soap solution around the sealed areas and inspect joints for "air bubbles".

If, after five minutes, the pressure is still holding constant, and no "bubbles" are observed, slowly bleed the pressure and remove the gauge assembly. Replace oil. Leek must be located and repaired if pressure does not hold.

**Pressure Test (If oil has NOT been drained)**

- Oil should be at normal level. Remove pipe plug (4) from housing (15). Apply pipe sealant to pressure gauge assembly and tighten into hole. Pressurize motor housing to 10 P.S.I. Use soap solution around the sealed areas above the oil level and inspect joints for "air bubbles". For sealed areas below oil level, leaks will seep oil. If, after five minutes, the pressure is still holding constant, and no "bubbles" / oil seepage is observed, slowly bleed the pressure and remove the gauge assembly. Replace oil. Leek must be located and repaired if pressure does not hold.



**Figure 2**

**Service**



Pressure builds up extremely fast, increase pressure by "TAPPING" air nozzle. Too much pressure will damage seal. **DO NOT exceed 10 P.S.I.**



**Seal Chamber** - Set pump on its side with fill plug (22) downward, remove plug (22) and drain all oil from seal chamber. Apply pipe sealant to pressure gauge assembly and tighten into hole in intermediate coupling (21). Pressurize seal chamber to 10 P.S.I. and check for leaks.

**Oil Replacement**

**Motor Housing** - Drain all oil (if not already done so) from motor housing and dispose of properly per Local and Environmental Standards.

Set pump upright and refill with new cooling oil, see "Cooling Oil" chart. Fill to just above motor as an air space must remain in the top of the motor housing to compensate for oil expansion. Apply pipe thread compound to threads of pipe plug (4) then assemble to motor housing (15).

**Seal Chamber** - Drain all oil (if not already done so) from seal chamber and dispose of properly per Local and Environmental Standards. Place pump on its side with plug (22) upward, and refill with new oil, see "Cooling Oil" chart. Apply pipe thread compound to threads of pipe plug (22) and assemble to intermediate coupling (21).



**DO NOT** overfill oil. Overfilling of housing with oil can create excessive and dangerous hydraulic pressure which can destroy the pump and create a hazard. Overfilling oil voids warranty.



Cooling Oil - 88 oz Recommended Supplier/Grade	
BP	Enerpar SE100
Conoco	Pale Paraffin 22
Mobile	D.T.E. Oil Light
Shell Canada	Transformer-10
Texaco	Diala-Oil-AX



**WARNING!** - Before any service work is done, disconnect and lock out electrical power to pump.

**Disassembly**

**Cutter** - Lay pump on its side and remove the cutter retaining screw (40) and washer (28). A small amount of heat may be needed to loosen screw. **DO NOT** overheat. Wedge a flat screwdriver between cutter and shredding ring and remove screw. With a hammer and punch, tap the cutter (29) counter-clockwise to remove.



**CAUTION!** - Cutter edges are very SHARP. Cutter must be removed before removing volute.

**Volute** - Remove hex nuts (41) from studs (34) and remove volute (25) from pump.

**Shredding Ring** - To replace or reverse the shredding ring (27) press out using an arbor press.

**Impeller** - Remove impeller (30) by turning counter-clockwise while holding the motor shaft stationary with a screwdriver. **NOTE:** Seal spring is relaxed with impeller removed, some oil may seep from seal cavity. **Do Not** store pump without impeller in place.

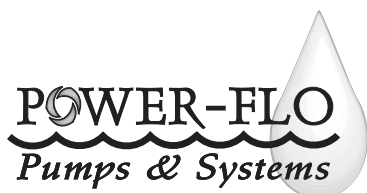
**Outer Seal** - Handle seal parts with care. Remove seal (33) spring and rotating member from shaft. Examine all seal parts. Inspect contact faces for signs of uneven wear tracks on stationary, chips and scratches on either seal face. **DO NOT interchange seal components, replace the entire shaft seal (33).**

**Seal Plate** - Remove cap screws (32) and washers (11) from seal plate (31). Remove seal plate (31) and square ring (24) from intermediate coupling (21). With flat screwdriver, press out seal (33) stationary member. Inspect square ring (24) for cuts or abrasions.

**Motor** - Remove pipe plug (4) and drain oil if not already done so. Position pump upright using blocks or pvc pipe to avoid resting pump on the shaft. Remove cap screws (1) and lockwashers (2) from cable assembly (3) and remove cable assembly (3) by pulling straight up. Remove retaining ring (38). Using a 1/4-20 bolt, thread bolt into the center of the terminal block (37) and pull straight up to remove. Disconnect all wires, noting where each was connected. There are numbers next to the pins on the bottom of block, use these for reference.

Remove cap screws (35) and lockwashers (11) from motor housing (15). Vertically lift motor housing (15) from intermediate coupling (21) along with square ring (20), replace if cut or damaged. Remove stator bolts and carefully remove stator housing from rotor. Pull rotor out with bearing (18) and rotating member of inner seal.

Inspect motor winding for shorts and check resistance values. Check rotor for wear. If rotor or the stator windings are defective, the complete motor must be replaced.



**Bearings & Inner Seal** - Remove seal (19) rotating member and spring from rotor shaft. Press stationary from intermediate (21) with flat screwdriver. Examine all seal parts. Inspect contact faces for signs of uneven wear tracks on stationary, chips and scratches on either seal face. **DO NOT interchange seal components, replace the entire shaft seal (19).** Remove retaining ring (39) from shaft. Using a wheel puller or arbor press remove bearing (18) from shaft. Remove upper motor bearing from shaft with a bearing puller. (See Figure 3)

Check sleeve bearing (23) for excessive wear, if replacement is required, press sleeve from intermediate coupling (21).



**IMPORTANT! - All parts must be clean before reassembly. Handle seal parts with extreme care. DO NOT damage lapped surfaces.**

**Reassembly**

**Bearings** - Be careful not to damage the rotor shaft when replacing bearings. Using an arbor press, hold the rotor and press the upper bearing on the rotor shaft, applying force to the inner race of the bearing only. Replace upper retaining ring onto rotor shaft. In the same manner replace lower bearing (18) onto rotor shaft. Place lower retaining ring (39) onto shaft.

**Inner Seal** - Clean and oil seal cavity in intermediate coupling (21). Lightly oil (**Do not use grease**) outer surface of stationary member. Press seal's (19) stationary member firmly into intermediate coupling (21), using a seal tool or pipe. Nothing should come in contact with the seal face except the seal tool. Be sure the stationary is in straight. Place seal's (19) retaining ring and spring over shaft until seated on shaft shoulder. Slide a bullet tool over rotor shaft threads.

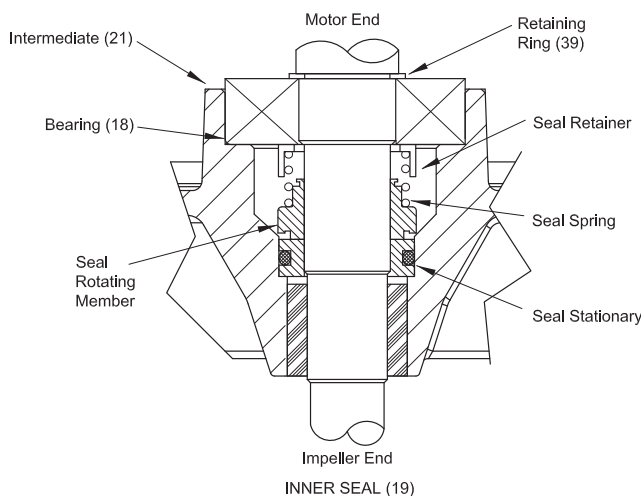
Lightly oil (**Do not use grease**) shaft, bullet, and inner surface of bellows on rotating member, with finished end away from motor, slide rotating member over bullet and onto shaft until it engages spring.

Make sure spring is seated in retaining ring and spring is lined up on rotating member and not cocked or resting on bellows tail. (See Figure 3)

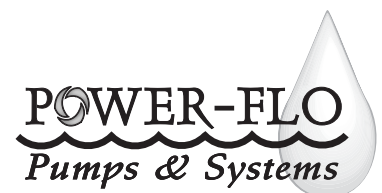
**Motor** - Slide rotor/shaft with bearing (18) and seal parts (19) into intermediate coupling (21) until bearing seats into intermediate coupling. Install retaining ring (39) into intermediate coupling (21). Place motor stator over rotor, lining up motor bolts with holes in intermediate coupling (21). Place end bell on top of motor and insert motor bolts and torque to 17 in-lbs.

Set square ring (20) in groove on intermediate coupling (21). Attach ground wire (36) to end bell if removed. Pull wires through opening in top of motor housing (15) while lowering motor housing onto intermediate coupling (21). Connect wires to pins on bottom of terminal block (37) as noted at disassembly and/or see wiring diagrams in Figure 7.

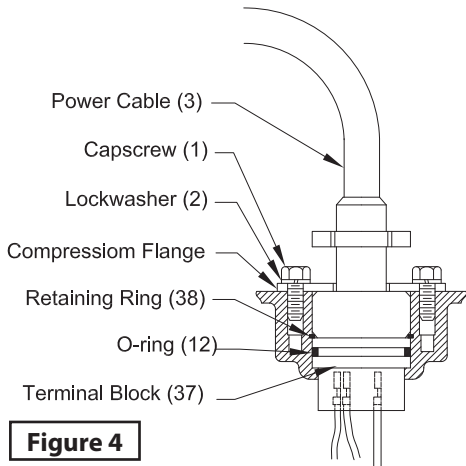
Lubricate o-ring (9) with dielectric oil and slide terminal block (37) back into housing (15). Be sure terminal block is engaged and install retaining ring (38). Place cap screws (35) with lockwashers (11) through housing (15) into intermediate coupling (21) and tighten. (See Figure 4)



**Figure 3**

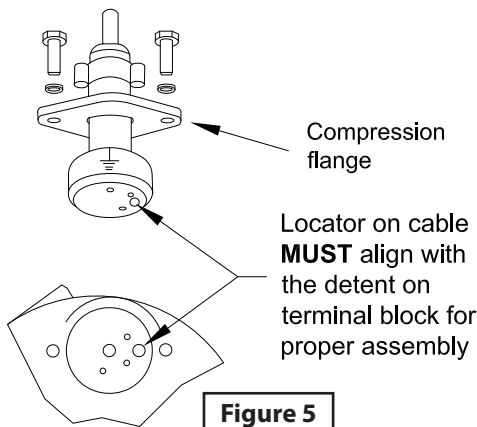


**Service**



**Figure 4**

**Power Cable Connection** - Check power cord (3) for cracks or damage and replace if required. Insert female end of cord plug into housing bore **aligning timing mark** with hole in terminal block (37) see Figure (5). Compress cord plug with compression flange by tightening cap screws (1) with lock washers (2) into the housing (15). Torque to 132 in-lbs.



**Figure 5**

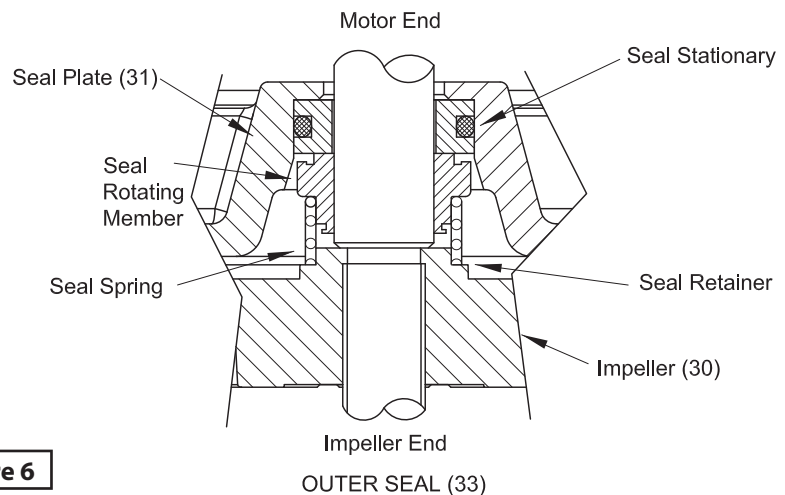
**Seal Plate** - Lubricate and set square ring (24) in bottom groove of seal plate (31). Place seal plate (31) over shaft and onto intermediate coupling (21), being sure square ring (24) is not twisted and in the groove. Place two capscrews (32) with lockwashers (11) into seal plate and torque to 6.5 ft/lbs.

**Outer Seal** - Clean and oil stationary seal cavity in seal plate (31). Slide seal guide tool over motor shaft. Lightly oil (**Do not use grease**) outer surface of seal's (33) stationary member. Press stationary firmly into seal plate (31) using a seal pusher tool. Be sure the stationary member is in straight. Nothing but the seal tool is to come in contact with seal face. (See Figure 6)

**IMPORTANT! Do not hammer on the seal pusher. It will damage the seal face.**

With seal guide tool over motor shaft, Lightly oil (**Do not use grease**) guide, shaft and inner surface of bellows on rotating seal. With lapped surface of rotating member facing inward toward stationary, slide rotating member over guide and onto shaft, using seal pusher tool, until lapped faces of stationary and rotating seal are together. Place spring over shaft and rotating member.

Be sure it is seated on the retainer and not cocked or resting on bellows tail.



**Figure 6**

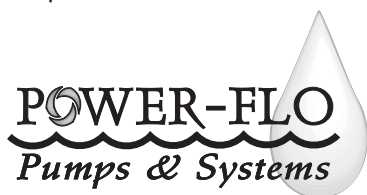
**Impeller** - Place impeller (30) on motor shaft, with machined step fitting inside the inside diameter of seal spring, by turning clockwise while holding shaft stationary with screwdriver.

**Shredding Ring** - Install shredding ring (27) into volute with the use of an arbor press.

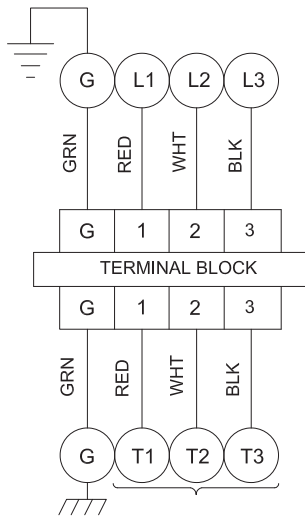
**Volute** - Place volute (25) on seal plate (31). Place nuts (41) with lockwashers (11) onto studs (34) and torque evenly to 11 ft/lbs.

**Note: Discharge must line up with notch in motor housing.**

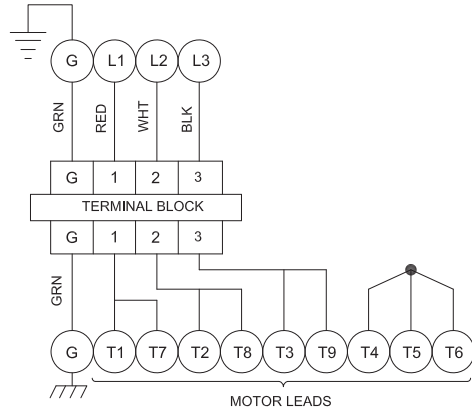
**Cutter** - Screw radial cutter (29) onto shaft, turning it clockwise while holding the shaft stationary with a screwdriver. The radial cutter (29) should be flush with shredding ring (27), on suction side to within  $\pm .020$ . Place washer (28) on screw (40), apply green Loctite on threads and place into shaft and tighten.



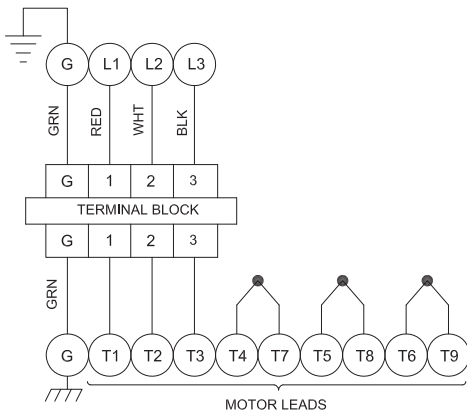
**Pump Wiring Schematics**



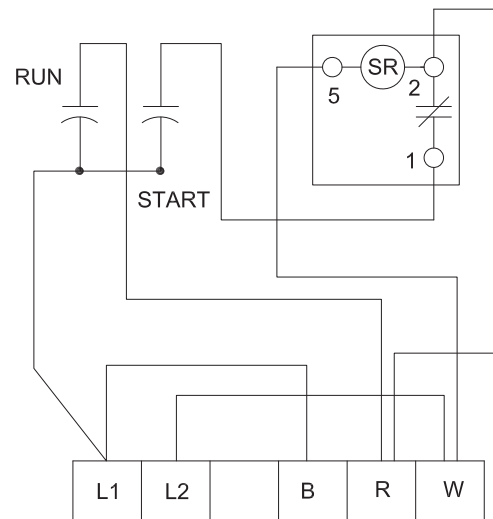
**Figure 7 - 200/230 Volt, 1Phase**



**Figure 7 - 200/240 Volt, 3Phase**

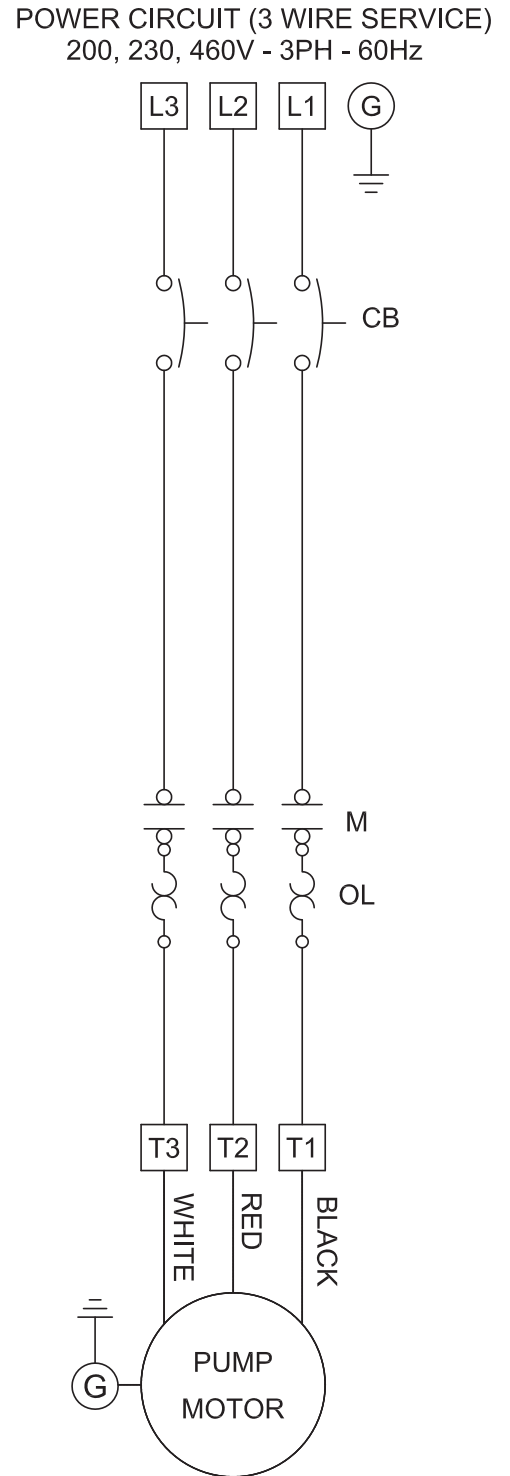
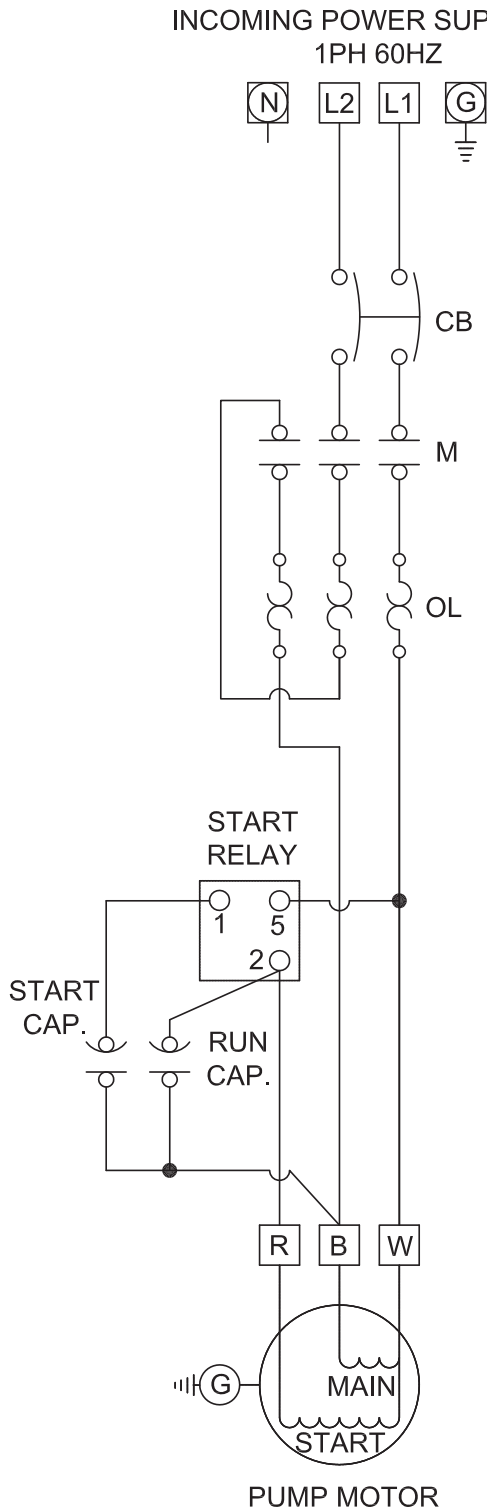


**Figure 7 - 460 Volt, 3Phase**



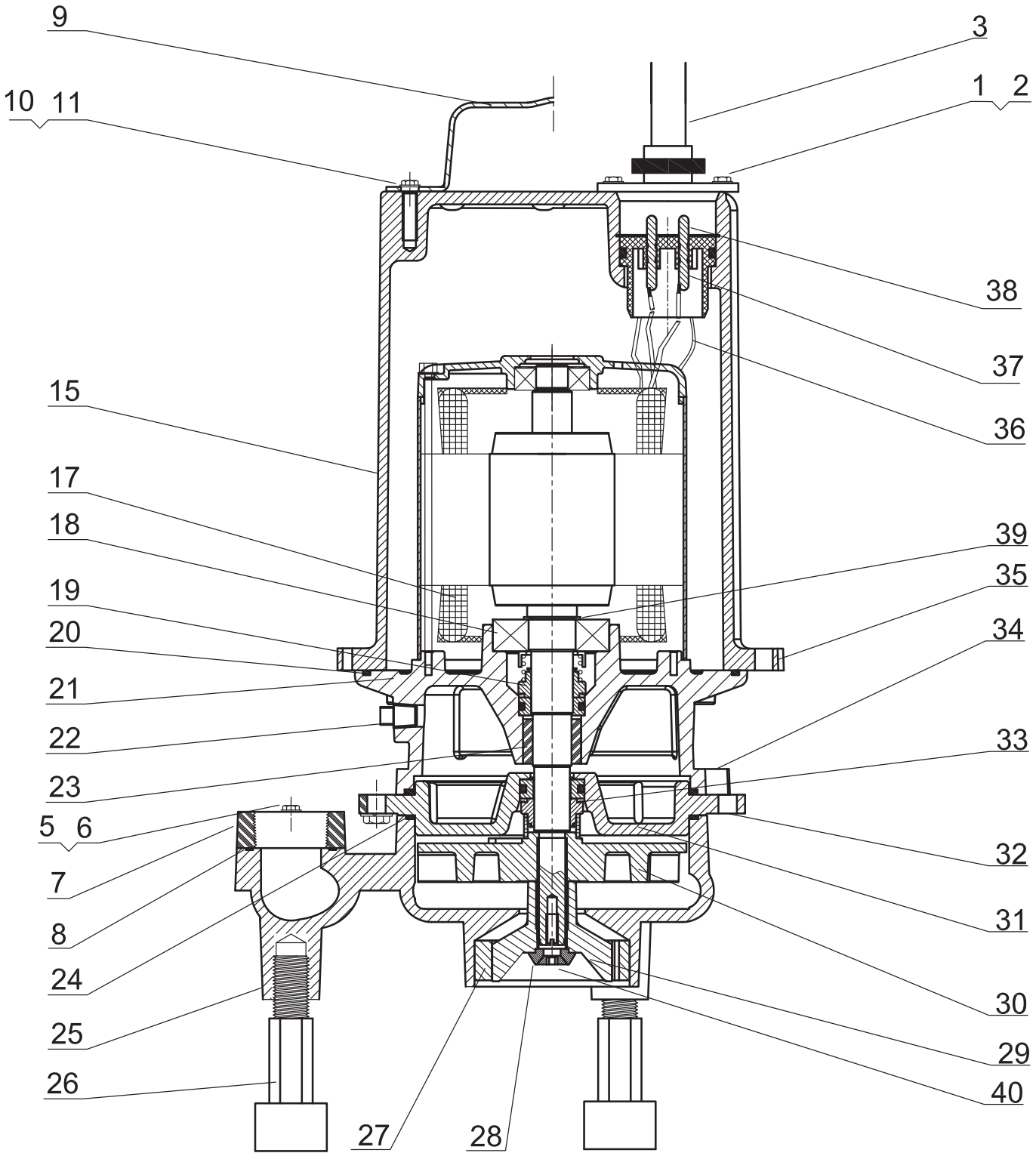
**1Phase Capacitor & Relay Pack  
For Control Panels:  
2HP, 200 V, 1 Ph - P/N: PF88243  
2HP, 230 V, 1PH - P/N: PF73306**

**Typical Panel Wiring Schematic**



For Repair Part Please supply: Model Number and MFG Date as shown on Name Plate, and Part Description and Part Number as shown on Parts List.

**Repair Parts**



**Figure 8**

Repair Parts

For Repair Part Please supply: Model Number and MFG Date as shown on Name Plate, and Part Description and Part Number as shown on Parts List.

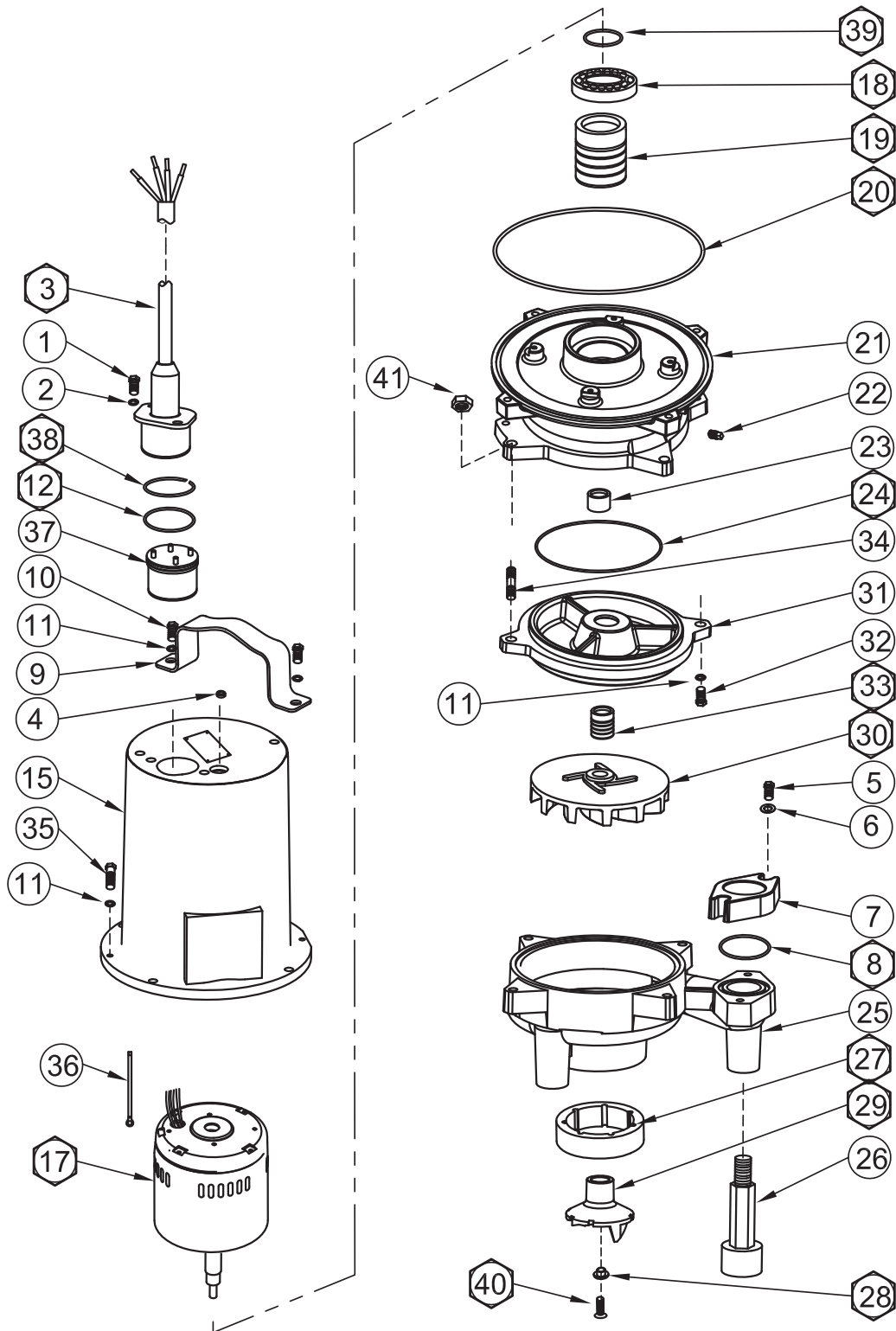


Figure 9



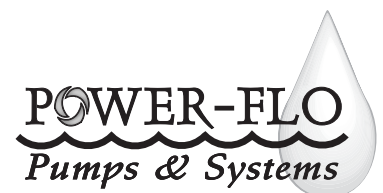


For Repair Part Please supply: Model Number and MFG Date as shown on Name Plate, and Part Description and Part Number as shown on Parts List.

**Repair Parts**

Ref. No.	Qty		Name	Used On	Part Number
1	2		Cap Screw 5/16-18 x 3/4" Lg., Stainless		◆
2	2		Lockwasher 5/16 Stainless		◆
3	1	☆	Power Cord, 20 Ft.		PF109492
4	1		Pipe Plug Counter Sunk, 3/8" NPT, Stainless		◆
5	2		Cap Screw 5/16-18 x 1-1/4" Lg., Stainless		◆
6	2		Washer 5/16" Stainless		◆
7	1		Discharge Flange		PF108369
8	1	●	O-ring		PF2-31051-224
9	1		Handle		PF103503
10	2		Cap Screw 5/16-18 x 3/4" Lg., Stainless		◆
11	10		Lockwasher 5/16 Stainless		◆
12	1	●	O-ring		PF2-31051-224
15	1		Housing		PF105196
17	1	☆	Motor	200/230 Volt 1 Ph	PF110397BG
				200 Volt, 3 Ph	PF067571BG
				230/460 Volt, 3 Ph	PF067572BG
18	1	●	Lower Bearing		PF10-36-E4
19	1	●	Inner Shaft Seal Carbon/Ceramic/Buna-N		PF111131
20	1	●	Square Ring		PF074498
21	1		Bearing Bracket		PF108879
22	1		Pipe Plug, 1/4" NPT		◆
23	1		Bronze Insert		----
24	1	●	Square Ring		PF067564
25	1		Volute		PF108344
26	3		Pump Leg		PF110660
27	1	●○	Shredding Ring	15 slots - HV	PF082085A
				7 slots - HH	PF082085B
28	1	●○	Impeller Washer		PF067556
29	1	●○	Radial Cutter		PF082088
30	1	☆	Impeller	5.13" - HV	PF109026B
				5.63" - HH	PF109026BTD
31	1		Seal Plate		PF108880
32	2		Cap Screw 5/16-18 x 1" Lg., Stainless		◆
33	1	●	Outer Shaft Seal Carbon/Ceramic/Buna-N		PF110395
34	4		Stud 5/16-18 x 2-1/4" Lg., Stainless		◆
35	6		Cap Screw 5/16-18 x 1-1/4" Lg., Stainless		◆

- ◆ = Acquire standard hardware locally.
- = Cutter Kit
- = Overhaul Kit
- ☆ = Supplied as individual items



**Repair Parts**

For Repair Part Please supply: Model Number and MFG Date as shown on Name Plate, and Part Description and Part Number as shown on Parts List.

Ref. No.	Qty		Name	Used On	Part Number
36	1		Ground Wire, 10GA.		PF105111A
37	1		Terminal Block		PF103586
38	1	●	Retaining Ring		PF105197
39	1	●	Retaining Ring		PF061143
40	1	●○	Impeller Screw 1/4-20 x 3/4" Lg., Stainless		PF070704
41	4		Hex Nut 5/16-18, Stainless		◆
	88 oz		Cooling oil		◆

**Repair Kits**

○	<b>CUTTER KIT</b> - Includes Item numbers: 27, 28, 29, 40				PFG2HV-CT PFG2HH-CT
●	<b>OVERHAUL KIT</b> - Includes Item numbers: 8, 12, 18, 19, 20, 24, 27, 28, 29, 33, 38, 39, 40				PFG2HV-OHK PFG2HH-OHK
	Capacitor Pack for PFG2002HV / HH Panel if other than a Power-Flo panel, 200 volt, 1 phase.				PF88243
	Capacitor Pack for PFG2022HV / HH Panel if other than a Power-Flo panel, 230 volt, 1 phase.				PF73306

- ◆ = Acquire standard hardware locally.
- = Cutter Kit
- = Overhaul Kit
- ☆ = Supplied as individual items

**Typical Name Plate**

**POWER-FLO** *Pumps & Systems*

---


Model Number

MFG Date

AMPS  VOLTAGE

PHASE

60 Hz HP



**POWER-FLO** *Pumps & Systems*  
877-24 PUMPS  
 www.powerflopumps.com

**Notes:**



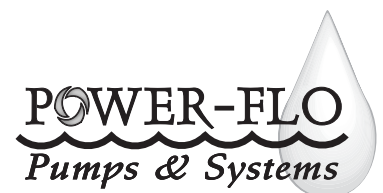

**Trouble Shooting Chart**



**Risk of electric shock. Always disconnect the pump from the power source before handling inspections or repairs.**

Symptom	Possible Cause(s)	Corrective Action
Pump will not run	Blown fuse or other interruption of power; improper voltage.  Switch is unable to move to the "turn ON" position due to interference with the side of basin or other obstruction  Insufficient liquid level  Defective level control	Check that the unit is securely plugged in. Have an electrician check all wiring for proper connections and adequate voltage and capacity.  Position the pump or switch so that it has adequate clearance for free operation.  Make sure the liquid level is allowed to rise enough to activate level control(s).  Remove and replace level controls
Pump will not turn off	Discharge is blocked or restricted  Check valve is stuck closed or installed backwards  Gate or ball valve is closed  Total lift is beyond pump's capability  Pump impeller is jammed or volute casing is plugged	Check the discharge line for foreign material, including ice if discharge line passes through or into cold areas  Remove check valve(s) and examine for freedom of operation and proper installation  Open gate or ball valve  Try to route piping to a lower level. If not possible, a larger pump may be required. Consult the factory  Disconnect unit electrically. Remove the pump from the basin. Detach the pump base and clean the area around the impeller. Rotate impeller by hand. Reassemble and reinstall
Pump will not turn off	Level control(s) unable to move to the "turn OFF" position due to interference with the side of basin or other obstacle  Defective level control	Position the pump or level control so that it has adequate clearance for free operation  Remove and replace level control
Pump runs periodically when fixtures are not in use	Check valve is stuck open or is leaking  Fixtures are leaking	Remove check valve(s) and examine for freedom of operation and proper installation  Repair fixtures as required to eliminate leakage
Pump operates noisily	Debris in the impeller cavity  Damaged impeller  Worn bearings  Piping attachments to building are too rigid	Remove the pump from the basin. Detach the pump base and clean the area around the impeller. Reassemble and reinstall  Consult the factory for information regarding replacement of impeller  Return pump to the factory or authorized repair station for repair  Replace a portion of the discharge line with rubber hose or connector

**NOTE:** Power-Flo Pumps & Systems assumes no responsibility for damage or injury due to disassembly in the field. Disassembly of the pumps or supplied accessories other than at Power-Flo Pumps & Systems or its authorized service centers, automatically voids warranty.



**LIMITED WARRANTY**

Manufacturer warrants, to the immediate purchaser and subsequent initial owner during the warranty period, every new pump to be free from defects in material and workmanship under normal use and service, when properly used and maintained, for a period of eighteen (18) months from date of manufacture or twelve (12) months from date of installation (which ever comes first). Failure due to wear due to excessive abrasives is not covered. The initial owner is the purchaser who first uses the pump after its initial installation, or for non-permanent installation, the first owner who uses the pump. The date of installation shall be determined by a dated sales receipt noting the model and serial number of the pump. The dated sales receipt must accompany the returned pump. Product will be repaired, replaced or remanufactured at Manufacturer's option. No allowance will be made for shipping charges, damages, labor or other charges that may occur due to product failure, repair or replacement. This warranty does not apply to and there shall be no warranty for any material or product that has been disassembled without prior approval of Manufacturer, subjected to misuse, misapplication, neglect, alteration, accident or act of God; that has not been installed, operated or maintained in accordance with Manufacturer's installation instructions; that has been exposed to outside substances including but not limited to the following: sand, gravel, cement, mud, tar, hydrocarbons, hydrocarbon derivatives (oil, gasoline, solvents, etc.), or other abrasive or corrosive substances, wash towels or feminine sanitary products, etc. in all pumping applications. The warranty set out in the paragraph above is in lieu of all other warranties expressed or implied; and we do not authorize any representative or other person to assume for us any other liability in connection with our products. Contact Manufacturer at: 1-877-24PUMPS or [www.powerflopumps.com](http://www.powerflopumps.com), Attention: Customer Service Department, to obtain any needed repair or replacement of part(s) or additional information pertaining to our warranty.

**MANUFACTURER EXPRESSLY DISCLAIMS LIABILITY FOR SPECIAL, CONSEQUENTIAL OR INCIDENTAL DAMAGES OR BREACH OF EXPRESSED OR IMPLIED WARRANTY; AND ANY IMPLIED WARRANTY OF FITNESS FOR A PARTICULAR PURPOSE AND OF MERCHANTABILITY SHALL BE LIMITED TO THE DURATION OF THE EXPRESSED WARRANTY.**

Some states do not allow limitations on the duration of an implied warranty, so the above limitation may not apply to you. Some states do not allow the exclusion or limitation of incidental or consequential damages, so the above limitation or exclusion may not apply to you. This warranty gives you specific legal rights and you may also have other rights which vary from state to state.

