

MODEL ACBC-120

Alarm Controller/Battery Charger



II-ACBC-120-B



www.SymCom.com

... your electronic control & protection specialists

222 Disk Drive, Rapid City, SD 57701
(800) 843-8848 www.symcom.com

DANGER!



HAZARDOUS VOLTAGES MAY BE PRESENT DURING INSTALLATION.

Electrical shock can cause death or serious injury.

Installation should be done by qualified personnel following all national, state and local electrical codes.



**BE SURE POWER IS DISCONNECTED PRIOR TO INSTALLATION!
FOLLOW NATIONAL, STATE AND LOCAL CODES.
READ THESE INSTRUCTIONS ENTIRELY BEFORE INSTALLATION.**

SymCom's Model ACBC-120 is a combination Alarm Controller/Battery Charger device. When 120VAC input power is present, the device acts as a Battery Charger charging a 12VDC backup battery. When there is a loss of 120VAC power, the device's primary function as an Alarm Controller becomes active. In this case, input power is switched to the backup battery and the ACBC-120 powers a 12VDC alarm circuit consisting of an alarm strobe light and/or a horn. An indicator LED on the unit also signals that the device has entered alarm mode. When 120VAC input power is present, the alarm circuit is able to be tested by pressing the TEST button on the front of the unit or by activating an external switch via the ALARM CONTACT pin. In alarm mode, the horn is functioning for 2 seconds on and 2 seconds off. The ACBC-120 includes a horn silence option to turn off the horn in alarm mode.

The ACBC-120's secondary function is to charge a backup battery in an alarm system. The battery must be of the 12VDC lead-acid rechargeable type. The device can source up to 100mA of charging current in fast charge mode, but normally charges at a maintenance current of 14mA in maintenance mode. The ACBC-120 signals a low battery condition if the battery voltage falls below 10.5V. The device also detects if there is no battery connected or if the battery is connected backwards. If one of these two conditions occurs, the ACBC-120 will signal battery error and will not attempt to charge.

CONNECTIONS

1. Mount the ACBC-120 in a convenient location. If the location is wet or dusty, it should be mounted in a NEMA 4 or NEMA 12 enclosure. Refer to Figure 1 for the following connections.
2. Connect 120VAC power to relay socket terminals 2 and 7 (LINE and NEUTRAL).
3. Connect the backup battery terminals to relay socket terminals 4 and 5 (BATT+ and BATT-).

NOTE: BATT- SHOULD NOT BE TREATED AS GROUND FOR THE ACBC-120 UNIT.

4. Connect strobe light alarm to relay socket terminals 3 and 6 (STROBE+ and STROBE-).
5. Connect horn alarm to relay socket terminals 1 and 8 (HORN+ and HORN-).
6. Connect alarm contact switch to relay socket terminals 10 and 3 (ALARM CONTACT and STROBE+).
7. Connect an optional horn silencing switch to relay socket terminals 11 and 12 (SILENCE+ and SILENCE-).
8. Plug the ACBC-120 into the 12-pin relay socket, making sure that the pin numbers match with the relay socket terminals.

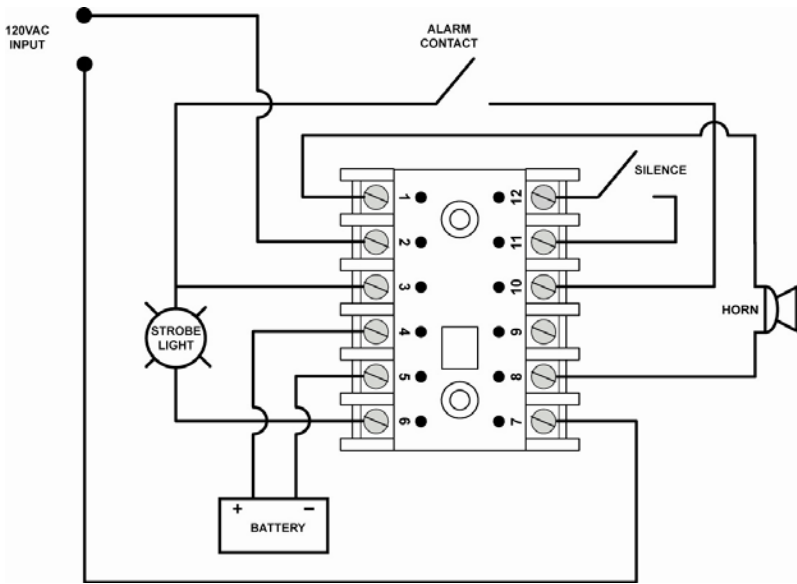

Figure 1: Typical Wiring Diagram

Terminal Number	Terminal Designations	Description
1	HORN+	Positive Horn Terminal
2	LINE	120VAC Line
3	STROBE+	Positive Strobe Light Terminal / Alarm Contact Switch
4	BATT+	Positive Battery Terminal
5	BATT-	Negative Battery Terminal
6	STROBE-	Negative Strobe Light Terminal
7	NEUTRAL	120VAC Neutral
8	HORN-	Negative Horn Terminal
9	NC	Not Connected
10	ALARM CONTACT	Alarm Contact Switch
11	SILENCE	Horn Silencing Switch
12	SILENCE	Horn Silencing Switch

Table 1: ACBC-120 Terminals

PIN DESCRIPTIONS

120VAC MAIN POWER

Pins 2 and 7 are connections to the 120VAC power source Line and Neutral, respectively. The ACBC-120 monitors this power source, and enters alarm mode when 120VAC power is not present.

BACKUP BATTERY

Pins 4 and 5 are connections to the 12VDC backup battery. The battery powers the product when 120VAC power is lost. When 120VAC power is present, the battery is maintained at full charge so that it is always prepared for an alarm condition.

STROBE LIGHT ALARM

Pins 3 and 6 are connections to the positive and negative terminals of an alarm strobe light. In alarm mode, the strobe light output will be active until the condition that signaled the alarm is no longer present.

HORN ALARM

Pins 1 and 8 are connections to the positive and negative terminals of an alarm horn. In alarm mode, the horn output will be pulsed on for 2 seconds and off for 2 seconds until the condition that signaled the alarm is no longer present.

ALARM CONTACT SWITCH

Pins 3 and 10 are connections to an external alarm contact switch. Closing the alarm contact switch puts the device in alarm mode. This remote alarm function enables the ACBC-120 to signal error conditions besides loss of 120VAC power. Opening the alarm contact switch returns the ACBC-120 to normal operation.

HORN SILENCING SWITCH

Pins 11 and 12 are connections to an external normally open switch. When the horn silence switch is closed, the horn output will be disabled. Opening the switch will enable the horn output. The horn silencing switch does not affect the strobe light alarm.

OPERATIONAL FEATURES

When power is applied to the ACBC-120, the device will enter one of the six modes listed below. If 120VAC power is present and the battery is connected properly, the ACBC-120 will start up in MAINTENANCE or FAST CHARGE mode. Table 2 below shows the six modes and how they are represented by the indicator light.





Mode	LED Pattern	LED Color
MAINTENANCE	SOLID	GREEN
FAST CHARGE		
TRIP DELAY		RED
BATT ERROR		
LOW BATT		
ALARM	SOLID	

Table 2: Diagnostic Indicator Light Conditions

MAINTENANCE Mode

MAINTENANCE is represented by a solid green light. In this mode, the battery connected to the ACBC-120 is close to or at full charge. The ACBC-120 may be applying a small maintenance charge current of around 14mA to maintain the battery at full charge. The ACBC-120 will stay in maintenance mode until it is overridden by an alarm or battery error.

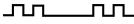
FAST CHARGE Mode

FAST CHARGE is represented by a flashing green light. In this mode, the battery's state of charge is below 100% and the ACBC-120 is attempting to restore the battery voltage by applying a fast charge current of 100mA. The ACBC-120 will stay in fast charge mode until a temperature-dependent charging voltage has been reached, or until it is overridden by an alarm or battery error.

TRIP DELAY Mode

TRIP DELAY is represented by a flashing red light. In this mode, the ACBC-120 has detected a loss of 120VAC power and is cycling through a 5 second trip delay before it enters alarm mode. This feature is included to prevent momentary power loss glitches from putting the device in alarm mode.

BATT ERROR Mode

BATT ERROR is represented by intermittent red light flashes (two flashes followed by brief pause). In this mode, the ACBC-120 is signaling one of the following battery errors:

- No battery present
- Reverse polarity

If the ACBC-120 is signaling BATT ERROR, check the battery and make sure the terminals are making good connection and are connected with the correct polarity.

NOTE: THE ACBC-120 WILL STAY IN BATT ERROR MODE UNTIL THE PROBLEM IS FIXED.

LOW BATT Mode

LOW BATT is represented by a solid red light with intermittent off flashes. In this mode, the ACBC-120 has detected that the battery is below 10.5V, the 0% state of charge level for a 12V lead-acid battery. The ACBC-120 will apply a 100mA charge current to raise the battery voltage as quickly as possible. When the battery reaches 10.5V, the device will indicate fast charge mode unless interrupted by an alarm or battery error.

ALARM Mode

ALARM is represented by a solid red light. In this mode, the ACBC-120 switches power to the backup battery to operate the external alarm circuitry. It turns on an alarm strobe light, and intermittently powers a horn alarm (2 seconds on, 2 seconds off). Alarm mode is initiated one of three ways:

1. Loss of 120VAC power (after a 5 second trip delay)
2. Pressing the TEST button
3. Closing an external ALARM CONTACT switch

The device will return to normal operation immediately when 120VAC power has been restored, or when the TEST and ALARM CONTACT functions are returned to their normal state.

TEST Button

The ACBC-120 includes a TEST button on the front of the unit that allows the user to test the backup battery alarm circuit without having to disconnect 120VAC power. Pressing the button will put the device in alarm mode until the button is released.

DIMENSIONS

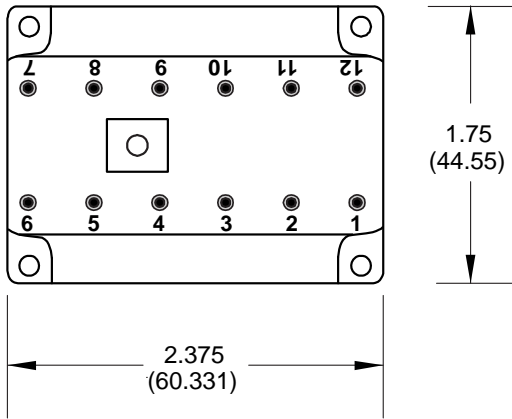

BOTTOM

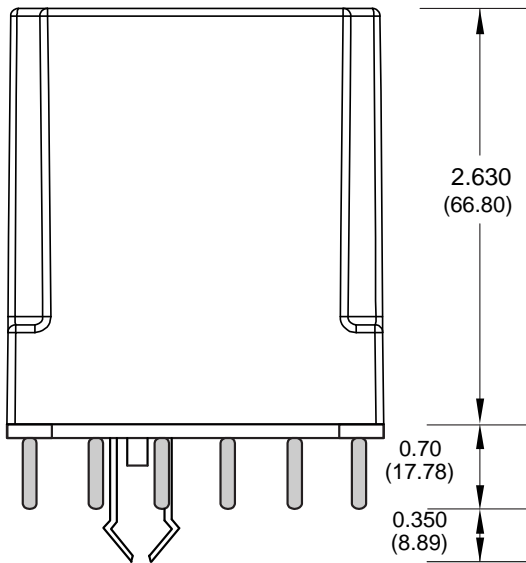

SIDE

Figure 2: ACBC-120 Dimensions

NOTE: Use of the SD12-PC rectangular socket, manufactured by Custom Connector Corp., is required for the ACBC-120 to qualify as a UL Listed device.

ACBC-120 SPECIFICATIONS

Functional Characteristics	
Battery Charging Characteristics	
Acceptable Battery Type	12V, Lead-Acid Rechargeable
Fast Charge Current	100mA +/- 10%
Maintenance Charge Current	14mA +/- 50%
Low Battery Alert Level	10.5V
Input Characteristics	
AC Input Voltage	120V +/- 10%
Frequency	50/60Hz
AC Input Current	0.018A (max) 0.003A (typical)
AC Input Power	2.4W (max) (fast charge current) 0.4W (typical) (maintenance charge current)
Output Characteristics	
Strobe Light Alarm Output	12VDC @ 1A (max)
Horn Alarm Output	12VDC @ 1A (max)
General Characteristics	
Environmental	
Operating Temperature	Surrounding Air: -40° to 60°C (-40° to 140°F)
Relative Humidity	10-85%, non-condensing per IEC 68-2-3
Standards Passed	
Electrostatic Discharge	IEC61000-4-2, Level 3, 6kV contact, 8kV air
Radio Frequency Immunity, Radiated	150MHz, 10V/m
Electrical Fast Transient Burst	IEC61000-4-4, Level 4, 4kV input lines; 4kV signal lines
Surge Immunity IEC	IEC61000-4-5, Level 4, 2kV line-to-line
ANSI/IEEE	C62.41 Surge and Ring Wave Compliance to a level of 6kV line-to-line
Hi-Potential Test	Meets UL508 (2 x rated V + 1000V for 1 minute)
Safety Marks	
UL listed (SD12-PC socket required)	UL508 (File # E68520, Model # 1-4-3-12)
CE	IEC60947-6-2
Dimensions	2.211" H x 2.606" W x 3.732" D (with socket)
Weight	9 oz.
Enclosure Material	Polycarbonate
Mounting Method	Plugs into 12-Pin SD12-PC Socket
Wire Gauge	12-20 AWG Solid or Stranded
Terminal Torque for SD12-PC Socket	20 in.-lbs. max

For warranty information, please see **Terms and Conditions** at
www.symcom.com

*Visit us at www.symcom.com to see
our complete product listing!*

Need something special?

*Contact SymCom today
for your custom solution!
800-843-8848*