



INSTALLATION INSTRUCTIONS FOR THE MotorSaver[®] Plus MODEL 777-P, 777-575-P, 777-HVR-P ELECTRONIC OVERLOAD RELAY

**BE SURE POWER IS DISCONNECTED PRIOR TO INSTALLATION!
FOLLOW NATIONAL, STATE AND LOCAL CODES.
READ THESE INSTRUCTIONS ENTIRELY BEFORE INSTALLATION.**

The Model 777-P is a solid-state (electronic) overload relay. It is fully programmable for customized protection and is designed to protect 3-phase systems with operating voltages of 190-480VAC (500-600VAC for the Model 777-575-P). The output relay is a Form C contact, which can control a contactor or other device within the output relay contact rating. The unit can be programmed prior to installation by applying 120VAC to terminals L1 and L2 (except Model 777-575-P). The unit cannot be tested for proper operation using this voltage. For testing purposes, 3-phase power must be applied with a minimum voltage of 190VAC (450VAC for the Model 777-575-P). The 777-P offers more advanced network programmable features than the 777 and will work with SymCom's DeviceNet COM-DN and CIO-DN; and Modbus RS485MS-2W Communications Modules.

DANGER!



HAZARDOUS VOLTAGES MAY BE PRESENT DURING INSTALLATION.

Electrical shock can cause death or serious injury.

Installation should be done by qualified personnel following all national, state and local electrical codes.



CONNECTIONS

1. Disconnect power and verify power is off.
2. Using the four corner tabs or the DIN rail mount, install the 777-P directly above or below the contactor. To use the DIN rail mount, hook the top clip first then apply downward pressure until the lower clip snaps onto the rail.
3. A) For amperages from 25-90 amps, insert the motor conductors through the holes marked A, B, and C. Make certain the conductor through each hole corresponds to the right motor conductor, i.e. the A phase conductor should go through the A round hole. See Figure 1 for a typical wiring diagram.
B) For amperages less than 25 amps, loop the motor conductors according to Table 1. Figure 3 shows an example of the looping required for current ranging from 8-12 amps (MULT=3).
C) For amperages greater than 90 amps, external CTs (current transformers) are required. SymCom recommends using CTs with terminals for ease of installation. All CT secondaries must make five passes through the round holes on the MotorSaver[®] Plus. See Figure 2 for a typical wiring diagram using external CTs.
NOTE: Pay close attention to this diagram to eliminate any power factor errors, when communicating with the device through the RS-485 network.
4. Connect the 3-phase power from the line side of the contactor to L1, L2, and L3 terminals using 12-18 AWG copper wire. These should be tightened to no more than 7 inch lbs.
5. Connect the control circuit wires to the appropriate terminals. The relay is designed for fail-safe operation, thus the NO (normally open) contact should be in series with the coil on the contactor for motor control (see Figure 1). For alarm circuits, the NC (normally closed) contact is in series with the alarm circuitry.



SymCom Inc
Motor Protection & Controls Since 1974

2880 North Plaza Drive, Rapid City, South Dakota 57702
(800) 843-8848 · (605) 348-5580 · fax (605) 348-5685
www.symcom.com

Recommended Full Load Amps	OC Range (Amps)	UC Range (Amps)	# of Passes through each Window	MULT (CT Ratio)																																																												
2-2.5	2-10	0, 1-9.8	10	10																																																												
2.5-3	2.2-11.1	0, 1.1-10.8	9	9																																																												
3-3.5	2.5-12.5	0, 1.2-12.2	8	8																																																												
3.5-4	2.8-14.3	0, 1.4-14	7	7																																																												
4-5	3.3-16.7	0, 1.6-16.3	6	6																																																												
5-6	4-20.1	0, 2-19.6	5	5																																																												
6-8	5-25.1	0, 2.5-24.5	4	4 </tr <tr> <td>8-12</td> <td>6.6-33.5</td> <td>0, 3.3-32.6</td> <td>3</td> <td>3</td> </tr> <tr> <td>12-25</td> <td>10-50.3</td> <td>0, 5-49</td> <td>2</td> <td>2</td> </tr> <tr> <td>25-90</td> <td>20-100</td> <td>0, 10-98</td> <td>1</td> <td>1</td> </tr> <tr> <td>80-110</td> <td>80-140</td> <td>0, 40-140</td> <td>5</td> <td>100 (100:5)</td> </tr> <tr> <td>110-160</td> <td>120-210</td> <td>0, 60-210</td> <td>5</td> <td>150 (150:5)</td> </tr> <tr> <td>160-220</td> <td>160-280</td> <td>0, 80-280</td> <td>5</td> <td>200 (200:5)</td> </tr> <tr> <td>220-320</td> <td>240-420</td> <td>0, 120-420</td> <td>5</td> <td>300 (300:5)</td> </tr> <tr> <td>320-420</td> <td>320-560</td> <td>0, 160-560</td> <td>5</td> <td>400 (400:5)</td> </tr> <tr> <td>400-520</td> <td>400-700</td> <td>0, 200-700</td> <td>5</td> <td>500 (500:5)</td> </tr> <tr> <td>480-600</td> <td>480-840</td> <td>0, 240-840</td> <td>5</td> <td>600 (600:5)</td> </tr> <tr> <td>540-700</td> <td>560-980</td> <td>0, 280-980</td> <td>5</td> <td>700 (700:5)</td> </tr> <tr> <td>560-800</td> <td>640-992/FFF</td> <td>0, 320-992/FFF</td> <td>5</td> <td>800 (800:5)</td> </tr>	8-12	6.6-33.5	0, 3.3-32.6	3	3	12-25	10-50.3	0, 5-49	2	2	25-90	20-100	0, 10-98	1	1	80-110	80-140	0, 40-140	5	100 (100:5)	110-160	120-210	0, 60-210	5	150 (150:5)	160-220	160-280	0, 80-280	5	200 (200:5)	220-320	240-420	0, 120-420	5	300 (300:5)	320-420	320-560	0, 160-560	5	400 (400:5)	400-520	400-700	0, 200-700	5	500 (500:5)	480-600	480-840	0, 240-840	5	600 (600:5)	540-700	560-980	0, 280-980	5	700 (700:5)	560-800	640-992/FFF	0, 320-992/FFF	5	800 (800:5)
8-12	6.6-33.5	0, 3.3-32.6	3	3																																																												
12-25	10-50.3	0, 5-49	2	2																																																												
25-90	20-100	0, 10-98	1	1																																																												
80-110	80-140	0, 40-140	5	100 (100:5)																																																												
110-160	120-210	0, 60-210	5	150 (150:5)																																																												
160-220	160-280	0, 80-280	5	200 (200:5)																																																												
220-320	240-420	0, 120-420	5	300 (300:5)																																																												
320-420	320-560	0, 160-560	5	400 (400:5)																																																												
400-520	400-700	0, 200-700	5	500 (500:5)																																																												
480-600	480-840	0, 240-840	5	600 (600:5)																																																												
540-700	560-980	0, 280-980	5	700 (700:5)																																																												
560-800	640-992/FFF	0, 320-992/FFF	5	800 (800:5)																																																												

Table 1: Wiring Configuration Based on Motor load Amps

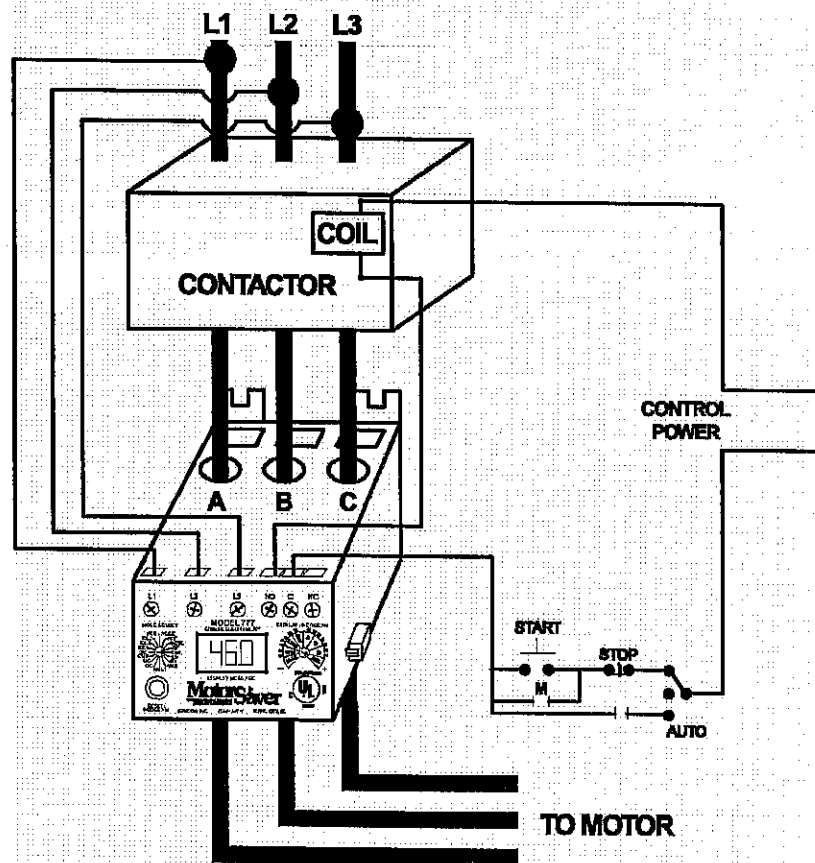
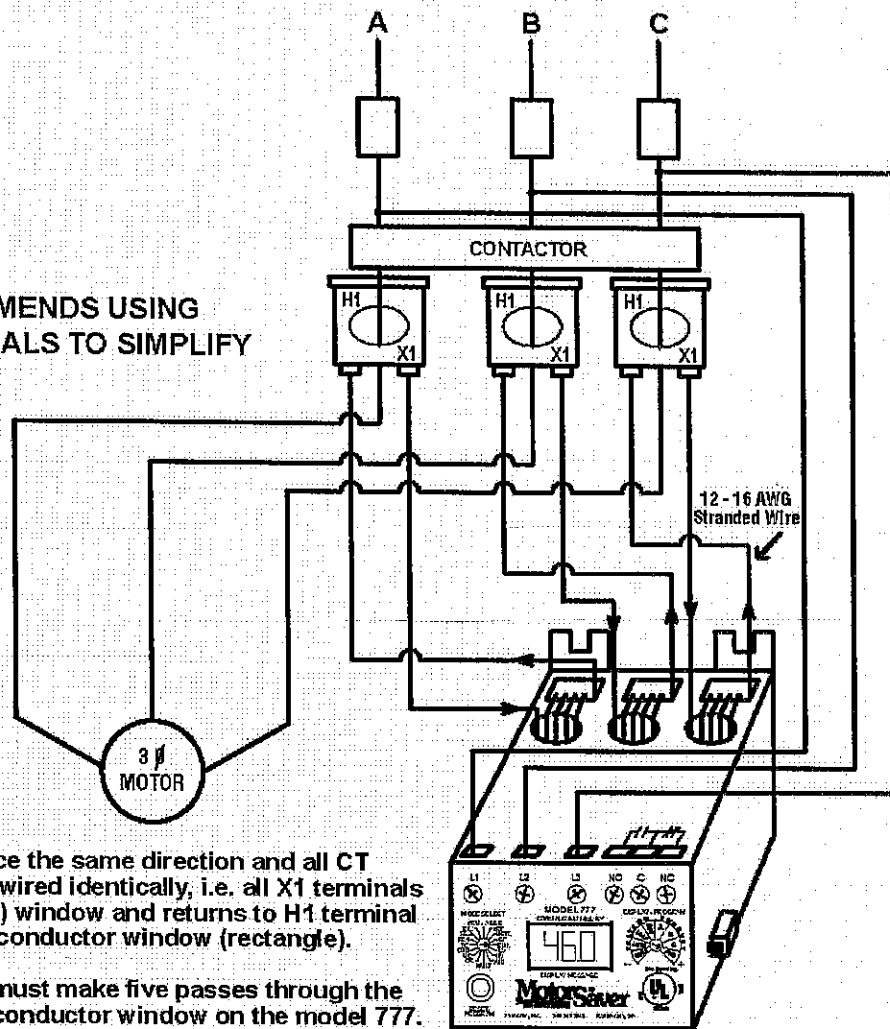

Figure 1: Typical Wiring Diagram for FLA of 26-90

SYMCOM RECOMMENDS USING CTs WITH TERMINALS TO SIMPLIFY INSTALLATION.



Note: All CTs must face the same direction and all CT secondaries must be wired identically, i.e. all X1 terminals enter the main (round) window and returns to H1 terminal after exiting the loop conductor window (rectangle).

Every CT secondary must make five passes through the corresponding main conductor window on the model 777.

Figure 2: Typical Wiring Diagram Using External CTs.

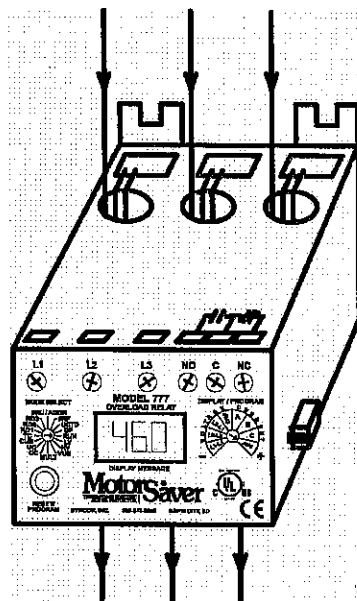

Figure 3: Looping Example Showing Three Conductors (MULT=3 from Table 1) (No other necessary connections are shown.)

PROGRAMMABLE PARAMETERS

The following settings MUST be programmed by the user in order to provide proper protection for the application. All parameters are actual values except for the VUB and CUB settings; these are programmed as percentages. The range each parameter can be programmed to is found on the electrical specifications table on pages 15 and 16. See pages 9 and 10 for programming examples.

LV/HV - The recommended settings for LV (low voltage) and HV (high voltage) according to the NEMA MG1 standard are $\pm 10\%$ of the motors nameplate voltage. For other settings, the motor manufacturer should be contacted.

Example: The motor nameplate voltage is 230 volts. 90% and 110% of 230 is $0.9 \times 230 = 207$ volts for the LV setting and $230 \times 1.1 = 253$ volts for the HV setting. These parameters are based on the average voltage going to the motor.

VUB - VUB (voltage unbalance) is factory set to 6%. The NEMA MG1 standard says a motor should not be operated above a 1% voltage unbalance without derating the motor. Most utility supplied power sources have a difficult time sustaining a 1% VUB. The motor manufacturer should be consulted for an exact VUB setting. Setting VUB to 999 will disable voltage unbalance protection but will not disable voltage SP protection.

Voltage unbalance is calculated as follows:

$$\% \text{Voltage Unbalance} = [(\text{Maximum deviation from the average}) / \text{Average}] \times 100\%$$

Example: Measured line-line voltages = 203, 210, and 212. The average = $(203 + 210 + 212) / 3 = 208.3$. The maximum deviation from the average is the greatest difference between the average voltage (208.3) and any one voltage reading; $212 - 208.3 = 3.7$, $210 - 208.3 = 1.7$ and $208.3 - 203 = 5.3$. The maximum deviation from the average is 5.3, thus voltage unbalance = $5.3 / 208.3 \times 100 = 2.5\%$.

MULT - MULT (multiplier) setting is found on Table 1. The MULT setting is determined by the current the unit will be monitoring. This allows the unit to display the correct current. Set MULT first then set UC, OC and GF.

OC - OC (overcurrent) is typically set to the service factor amperage (SFA) of the motor or 100-115% of motor full-load amps (FLA), which are determined by the motor manufacturer. If any one leg exceeds the OC setting, the 777-P will follow the TC settings to determine when to trip; in seconds or by following the trip class curve (see Figure 4).

UC - UC (undercurrent) is typically set to 80% of the full-load amperage (FLA) of the motor. This is usually adequate for protection of loss of load for many pumps and motors, including submersibles. If the motor is not pulling near full load amperage then the UC may have to be set to something higher than 80% of FLA for adequate protection. UC can be set to 0 if UC protection is not desired. The 777-P examines average current to determine if an undercurrent trip condition exists.

CUB - CUB (current unbalance) is factory set to 7%. SymCom recommends contacting the motor manufacturer for a specific setting. Current unbalance is calculated the same way voltage unbalance is calculated (see formula above). Current unbalance protection can be disabled by programming CUB to 999. This will disable current unbalance protection and current single phasing protection.

TC - The TC (trip class) setting determines how quickly the 777-P will trip when an overload (overcurrent) condition is detected. TC is a dual-function setting—both a thermal trip class (NEMA standard) and a linear trip delay (in seconds) can be set to establish when the 777-

P will trip on overcurrent. While the standard trip classes are 5, 10, 15, 20, and 30, TC can be set from 2–30, with or without jam protection. These additional “non-standard” trip classes allow the unit to follow a trip curve in-between the “standard” trip class curves shown in Figure 4.

Trip classes 2–30 can be set from approximately the 7 o'clock to 11 o'clock position on the DISPLAY/PROGRAM dial. Trip classes J02–J30, which include jam protection, can be set from the 11 o'clock to 2 o'clock position (this additional jam protection feature, when enabled is initiated 1 minute after the motor starts and provides a 2-second trip delay for motors exceeding 400% of the OC setting).

The linear overcurrent trip delay can be set after the 2 o'clock position from 0–60 seconds (L00–L60) or to “oFF.” If TC is set to L00, the 777-P will trip off within 1 second when an overcurrent condition is detected.

If both trip class and linear trip delay settings are programmed, the 777-P will follow the faster trip time. E.g., let's say TC is set to J15 and L20, and the amperage is 200% of the OC setting. Following the trip class 15 curve, the 777-P will trip off in approximately 100 seconds. Thus the 777-P will follow the linear trip delay setting, because it is faster, and will trip off in 20 seconds.

The motor manufacturer should be contacted for an exact TC setting. Table 3 describes the trip classes, and Figure 4 shows the trip class curves.

- RD1 -** RD1 (restart delay one) is the rapid-cycle timer in seconds. This timer is initiated when power is first applied to the unit. If voltages are within the programmed limits and no SP (single-phase) or RP (reverse-phase) condition exists when power is applied to the device, the output relay will energize (the NO will close and the NC will open) as soon as RD1 expires. Typically, this is set to 20-30 seconds. This will provide adequate protection for successive power outages or short cycling caused by other motor controls. This timer is also initiated when another control shuts the motor off (current goes to zero). If the user does not want the unit's relay to de-energize when another control shuts the motor off, then RD1 should be set to zero. This will also ensure that when an alarm circuit is used, an alarm will sound only when there is a fault or power is lost.
- RD2 -** RD2 (restart delay two) is the restart timer, in minutes (standard), used when the unit has shut off due to a current unbalance, current single phasing, or an overload condition. This timer is known as a motor cool-down timer. A setting of 5-10 minutes will give most motors adequate time to cool down after an overload condition. The motor manufacturer should be contacted for an exact value.
- RD3-** (restart delay three) is the restart timer, in minutes (standard), used after an undercurrent trip. It is also known as a dry-well recovery timer in pumping applications. This would be the time it takes a well to recharge after pumping dry. This setting varies widely from application to application and there is no typical setting. RD3 can be set from 2-500 minutes or to A to enable the automatic Dry-Well Recovery Calculator.

The Automatic Dry-Well Recovery Calculator allows the 777-P to automatically select a restart delay based on the run time of the last run cycle. Table 2 shows the next restart delay vs. run time. In general, a longer run time produces a shorter restart delay. This feature allows the 777-P to optimize running and rest times automatically.

Run Time	Next Restart Delay (minutes)	Starts/Hr
> 1Hr	6	10
30 min.- 59.99 min.	15	4
15 min.- 29.99 min.	30	2
< 15 min.	60	1

Table 2.: Automatic Dry-Well Recovery Timer

#RU/ADDR - The #RU/ADDR is a dual-function setting. #RU is displayed when the DISPLAY/PROGRAM knob is between the 7 o'clock and 11 o'clock position of the dial. ADDR is displayed above the 11 o'clock position on the DISPLAY/PROGRAM dial.

#RU is the number of restarts the 777-P will attempt after an undercurrent fault before the unit locks out and requires a manual reset. #RU can be set to 0, 1, 2, 3, 4, or A. This counter is cleared one minute after restarting if the 777-P does not trip again on undercurrent.

EXAMPLE: #RU set to 1

If the 777-P trips on undercurrent, restarts automatically (after RD3), then trips again on undercurrent within one minute, the 777-P will lock out and require a manual reset. On the other hand, if the 777-P restarts after an undercurrent fault, but runs without tripping on undercurrent for more than a minute, the unit will not lock out if an undercurrent fault occurs.

If #RU is set to "0," the 777-P will require manual resetting after all undercurrent faults. If #RU is set to "A," the 777-P will always restart automatically after undercurrent faults.

ADDR is the RS-485 address of the 777-P. This is only used when communicating with an RM-2000, RM-1000, COM-DN, CIO-DN, a PLC, or a PC. The address can be 1-99 (A01-A99).

#RF - #RF is the number of restarts the 777-P will attempt after current unbalance or current single-phase faults. This counter will be cleared one minute after start-up if the unit does not trip again on a current unbalance, or current single-phase condition (see example for #RU). Available settings are 0, 1, 2, 3, 4 and A, or to include overcurrent faults in this restart function, #RF can be set to oc1, oc2, oc3, oc4 or ocA.

If #RF is set to "0," the 777-P will require manual resetting after all current unbalance, single-phase and overcurrent faults.

If #RF is set to "A," the 777-P will always restart automatically after current unbalance and single-phase faults.

If #RF is set to "ocA," the 777-P will always restart automatically after current unbalance, single-phase and overcurrent faults.

UCTD - UCTD (undercurrent trip delay) is the length of time, in seconds (standard), the unit will allow the motor to run in an undercurrent situation before de-energizing its relay. Typically, UCTD is set to 2-4 seconds.

GF - GF (ground fault) is the maximum allowable current that can flow to ground before the 777-P de-energizes its relay. This is a residual, class II ground fault system and should not be used for personnel safety. A typical setting for GF is 10-20% of motor FLA (in amps). The GF test procedure in this installation instruction manual must be conducted before the device is brought online.

PROGRAMMING

1. Rotate the MODE SELECT switch to the parameter to be programmed. SymCom recommends that LV be programmed first and then move clockwise through the positions to complete the process.
2. Press and hold the RESET/PROGRAM button.
3. Rotate the DISPLAY/PROGRAM knob until the proper setting for the parameter that is being programmed is displayed.
4. Release the RESET/PROGRAM button. This stores the new parameter in the nonvolatile memory. If the number changes back to what it was before programming, then the tamper guard is on and will need to be unlocked before programming can be completed (see the TAMPER GUARD section for a complete description).
5. Continue steps 1-4 until all parameters are programmed.

OPERATION

The relay operation of the Model 777-P is designed to be fail safe. This means when everything is within the limits programmed into the unit, the relay will energize, the NO contact will close and the NC contact will open. Once the unit has been wired and programmed, the unit is ready to operate. Turn MODE SELECT to the RUN position. The display will show "run" alternating with some number (the numbers displayed will be the number corresponding to where the DISPLAY/PROGRAM knob is pointed). It will do this for the amount of time programmed into RD1. After this time has expired, the relay will energize (NO contact will close and the NC contact will open). If something else is in the display, see the troubleshooting section for more information. If MODE SELECT is taken out of the RUN position, the unit's relay will de-energize.

CLEARING LAST FAULT

The last fault stored can be cleared on the MotorSaver®Plus following these steps:

1. Rotate the MODE SELECT switch to GF.
2. Press and hold the RESET/PROGRAM button. Adjust the DISPLAY/PROGRAM adjustment until "cLr" appears on the display. Release the RESET/PROGRAM button.

To verify the last fault was cleared, place the MODE SELECT switch in the RUN position. Then press and hold the RESET/PROGRAM button; "cLr" should be on the display.

TAMPER GUARD

The MotorSaver's setpoints can be locked to protect against unauthorized program changes.

1. Rotate the MODE SELECT switch to GF.
2. Press and hold the RESET button. Adjust the DISPLAY/PROGRAM knob until "Loc" appears on the display.
3. Release the RESET button.
4. Turn MODE SELECT switch to RUN.

The program is now locked, but all settings can be viewed. The unit can be unlocked by following the same steps except adjust the DISPLAY/PROGRAM knob to "unL" in step 2.

Trip Class	Application Description
5	Small fractional horsepower motors where acceleration times are almost instantaneous or where extremely quick trip times are required
10	(Fast Trip) Hermetic refrigerant motors, compressors, submersible pumps and general-purpose motors that reach rated speed in less than 4 seconds.
15	Specialized applications.
20	(Standard Trip) Most NEMA-rated general-purpose motors will be protected by this setting.
30	(Slow Trip) Motors with long acceleration times (>10 seconds) or high inertia loads.
J Prefix	Programming any of the trip classes with the J prefix will enable jam protection. This additional protection is enabled 1 minute after the motor starts and provides a 2 second trip time for motors exceeding 400% of the OC setting, regardless of trip class.
LXX	This is linear overcurrent setting, where XX is the number of seconds for a linear trip.
Other Trip Classes	Trip Time in seconds at 6x OC=(TC*.93359s)

Table 3: Trip Class Descriptions

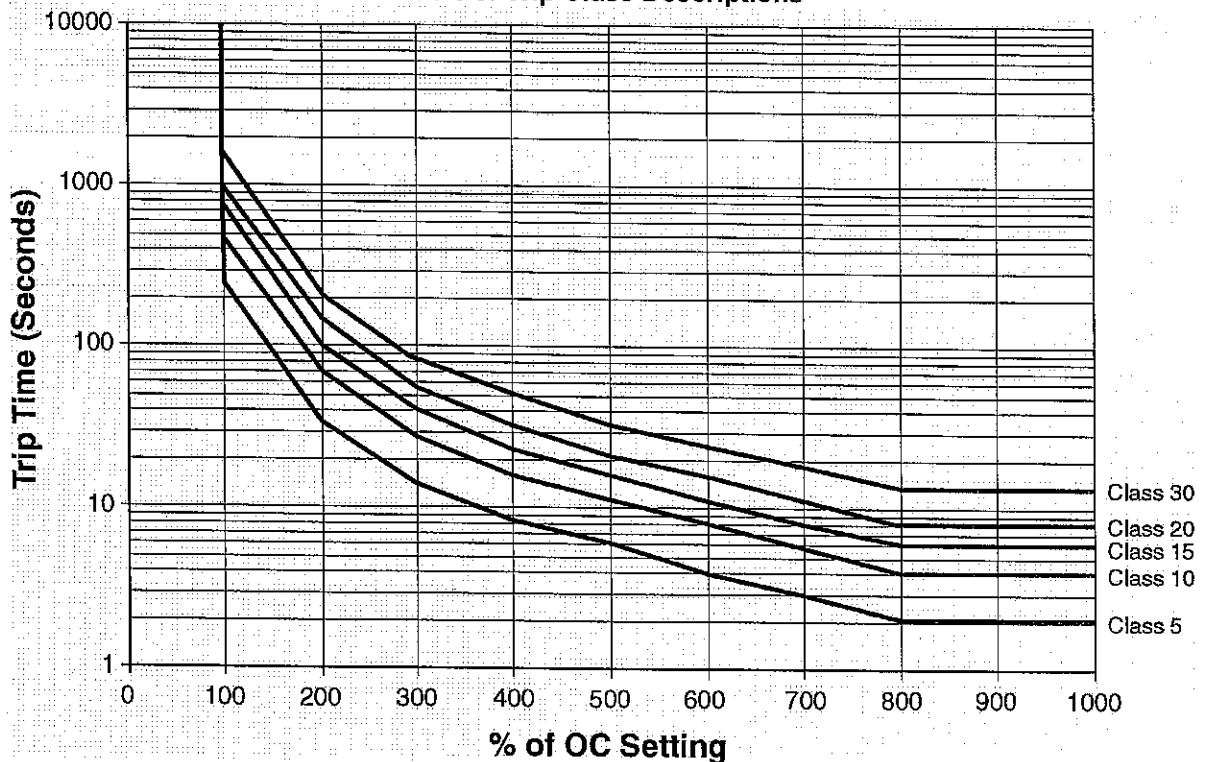

Figure 4: Overload Trip Curves

PROGRAMMING EXAMPLES

Example #1

Motor to be protected: 3-phase, 460 Volt, 25 hp air compressor with full load amperage rating of 34A and maximum service factor amps of 37.4. Use the following calculations and reasoning to determine the appropriate settings for this application.

LV-	$460 \times 0.90 = 414$
HV-	$460 \times 1.10 = 506$
VUB-	Standard NEMA motor = 5
MULT-	From Table 1 = 1
OC-	Service Factor Amperage = 37.4
UC-	$FLA \times 0.80 = 34A \times 0.80 = 27.2$
CUB-	Standard NEMA motor = 5
TC-	General purpose motor, TC = 20. No linear trip delay is desired, TC also = oFF.
RD1-	Since this compressor takes about 10 seconds to bleed off excess pressure after a shutdown, setting RD1 = 20 will allow the compressor to unload before being restarted.
RD2-	Because the motor may be hot from running in an unbalance or single phase condition, a motor cool-down time of 10 minutes, RD2 = 10, should be appropriate.
RD3/#RU-	Because an undercurrent would signal a serious problem in this application (a broken shaft or belt), #RU should be set to 0 for a manual reset. Therefore, RD3 does not have any function
#RF-	Because an overload (overcurrent) fault signals a serious problem in this application (e.g., worn bearings), "oc" should not be included in the #RF setting so that a manual reset after an overload fault is required. A #RF=1 will give the system 1 chance to recover from an unbalance or single phasing problem before manual reset is required.
UCTD-	Setting UCTD = 5 will allow normal operation and not allow the motor to run too long in a failure mode.
GF-	A ground fault setting of 15% of full load amps will be a significant indicator that the motor should be evaluated for repair or replacement. Therefore, $GF = 34A \times 0.15 = 5.1$.

Example #2

Motor to be protected: 3-phase, 230 Volt, 5 hp submersible pump with full load amperage of 15.9A and maximum service factor amps of 18.2. Use the following calculations and reasoning to determine the appropriate settings for this application.

LV-	$230 \times 0.90 = 207$
HV-	$230 \times 1.10 = 253$
VUB-	Manufacturer suggests 5
MULT-	From Table 1, MULT = 2, 1 loop of main conductor
OC-	Service Factor Amperage = 18.2
UC-	$FLA \times 0.80 = 15.9 \times 0.80 = 12.7$
CUB-	Manufacturer suggests 5
TC-	From Table 3, for this (and most) submersible pumps, TC = 10. No linear trip delay is required so TC also is set to oFF.

- RD1- To protect the pump from rapid cycling, RD1 = 60
- RD2- Since the motor is small and submerged in water, the motor will generally cool down quickly. RD2=5
- RD3- The well history shows that it will fully recover in 2 hours. RD3 = 120
- #RU- In this application, we know that the well will eventually recharge itself, #RU = A (Automatic).
- #RF- This well is known for sand to jam the impeller; therefore, "oc" should be included so that the pump will attempt to automatically restart after an overload condition. History shows that 2 or 3 starts and stops usually clears the sand from the impeller. #RF= oc2 or oc3.
- UCTD- This well may become air locked on startup, but will usually re-prime itself in 5 seconds or less. UCTD = 10
- GF- Because this type of fault indicates the impending failure of the motor and it may take several days to get a new pump and schedule for a driller to remove and replace the pump, GF setting of 10% of full load amperage will give the well owner enough time to prepare for pump replacement. $GF = 15.9A \times 0.10 = 1.59$

SYSTEM DISPLAY

The output display can show one of the following parameters when the MODE SELECT switch is in the RUN position: average voltage or current, each line current, or each individual line-line voltage. The display is also used for programming the operating parameters of the device. The display also identifies what caused the unit to de-energize its relay or what is keeping the unit from energizing its relay. The last fault (not the current fault) can be displayed by pressing and holding the RESET/PROGRAM button while the MODE SELECT switch is in the RUN position. When the unit trips off or is holding the motor off, the current fault condition will be shown in the display without pressing the button. Table 4 below lists the fault codes the unit could display.

Displayed Message	Meaning
oc	Tripped on overcurrent
SP	Tripped on current single phasing or unit won't start because the voltage is single phased
ub	Tripped on current unbalance or unit won't start because the voltage is unbalanced
uc	Tripped on undercurrent
CF	Tripped on contactor failure
GrF	Tripped on ground fault
HI	A high voltage condition exists
Lo	A low voltage condition exists
rP	Incoming phases have been reversed, the motor may run backwards if started
oFF	A stop command was issued from a remote source

Table 4: Fault Codes and Their Meaning

On power up, the 777-P will show the current software revision. For example if the software revision is 2904, the 777-P will show 029 followed by 004. This can be used to determine the model number of 777-P.

COMMUNICATIONS PORT/REMOTE RESET

The unit comes with a 9-pin sub-D connector for remote communications and/or for using a remotely located reset button. If communications are desired, a communication module (part number RS485MS-2W) needs to be plugged into this 9-pin connector (this is mandatory when communicating with the unit). This module provides isolation, signal conditioning for compatibility with Modbus RTU and RS-485 networks, and provides terminals for terminating the shielded communications cable. Up to 99 units can be installed on one RS-485 network.

Further information can be obtained at www.symcom.com or by calling in a request. A remote reset button can be hooked up to the communications module (part number RS485MS-2W) or can be hooked directly to the 9-pin connector using a male sub-D connector. It should be wired as shown in Figure 5.

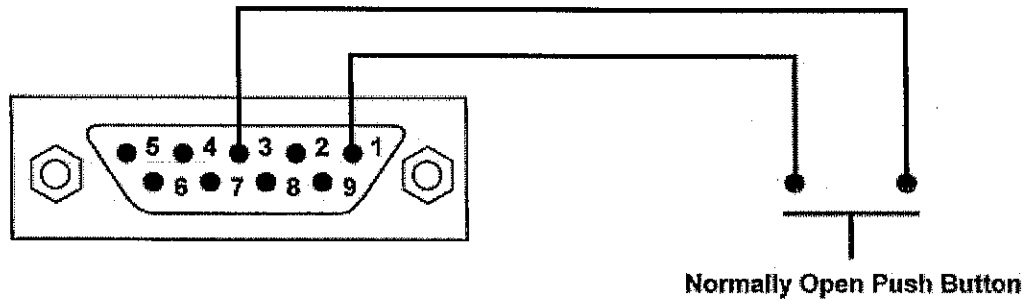

Figure 5: Remote Reset Button Wiring Diagram

TROUBLESHOOTING

The MotorSaver®Plus will display a fault code alternating with a number or with "run" when it is in a trip condition. If the unit is showing a fault code (see Table 4) alternating with "run," it has tripped on a current (amperage) condition. If the fault code is alternating with some number (voltage reading or zero), the unit will not allow the motor to start because there is a problem with the incoming voltage. If the display is showing just a fault code, the unit is in a mode that requires a manual reset. This could be because the number of restarts (#RF, #RU) has expired or is not allowed. If the display reads "off," a stop command was issued through the communications network.

PROBLEM	SOLUTION
The unit will not start. Display alternates "rP" with the DISPLAY/PROGRAM parameter value.	The voltage inputs are reverse phased. If this is the initial start-up, swap any two of the leads connected to L1, L2, or L3 on the 777-P to correct the problem. If the overload relay has been previously running, the power system has been reverse phased. Check the phase sequence of the incoming power lines. Note: L1 must be tapped from conductor Phase A, L2 from B, and L3 from C for correct power factor measurements on remote communications.
The unit will not start. Display alternates "SP", "ub", "HI", or "Lo" with the DISPLAY/PROGRAM parameter value.	The incoming voltage is not within the limits programmed in the VUB, HV, and LV settings. Adjust the DISPLAY / PROGRAM switch to read the incoming line voltage values. Correct the incoming power problem and check programmed limits to verify they are correct.
Display alternates "SP", "ub", or "oc" with "run."	The overload relay has tripped on the fault shown on the display and is timing down RD2 before restarting.
Display alternates "uc" with "run."	The overload relay has tripped on undercurrent and is timing down RD3 before restarting. If undercurrent is not a normal condition for this installation, check for broken shafts, broken belts, etc.
Display is showing a solid "SP", "ub", or "oc."	The unit has tripped on the fault shown and a manual reset is required because of the programmed setting in #RF. Check the system for problems that would produce the single-phase, overload or current unbalance fault, such as a jam.
Display is showing a solid "uc."	The unit has tripped on undercurrent and a manual reset is required because of the setting in #RU. Check the system for problems that would produce a loss of load such as a broken belt or a lack of liquid to pump.
Display is showing a solid "CF."	The unit has tripped on current single phasing, but was not single phased by the incoming voltage. Check for damaged contacts or loose wiring.
Display is showing a solid "GrF."	A ground fault current greater than the programmed GF value has been detected. A manual reset is required. Check the motor for insulation breakdown.

Table 4. Troubleshooting

GROUND FAULT TESTING PROCEDURE

A ground fault test must be performed before installing the MotorSaver®Plus as required by UL1053 and NEC, ANSI/NFPA 70.

1. Disconnect power.
2. Hook up the three line voltages to L1, L2, and L3 as required by the installation instructions.
3. Program the desired parameters into the unit. For test purposes, set MULT to 1 and GF to the minimum allowed setting.
4. Construct the circuit, using an AC power supply. This circuit simulates a ground fault condition by generating a current in one of the phases. Alternate test circuits may be used. The only requirement is the current through the current transformer must be between 115% and 150% of the GF setting and pass through only one CT window.

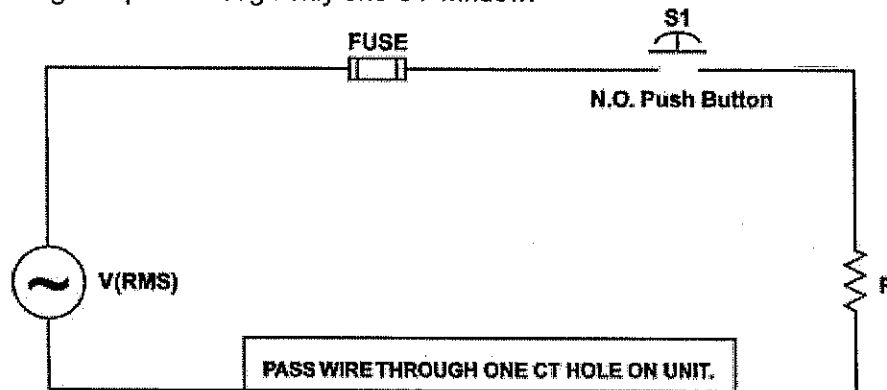

5. The values of V and R will be determined by the current required to generate a GF trip condition:
 $I = V_{rms}/R$, where $I = 115\%$ of GF setting.
6. Place the unit in the RUN position, apply 3-phase power and allow the NO contact to close.
7. Energize the test circuit by pushing and holding the test pushbutton until the unit trips (within 8.5 seconds). The display should show "GrF" and the NO contacts should be open. Release the NO pushbutton.
8. The results of the test are to be recorded on the test form provided below. The form should be kept by those in charge of the building's electrical installation in order to be available to the authority having jurisdiction.
9. Confirm programmed parameters and proceed with installation instructions.

GROUND FAULT TEST RESULTS*

Date **Performed by** **Results** **Location**

*A copy of this form should be retained by the building's electrical foreman.

MODEL 777-P SPECIFICATIONS	
ELECTRICAL	
3-Phase Input Voltage	200–480VAC (Model 777-P) 500–600VAC (Model 777-575-P*) 380–480VAC (Model 777-HVR-P****)
Frequency	50–60Hz
Motor Full Load Amp Range	2–25A, 3-phase (looped conductors required) 25–90A, 3-phase (direct) 80–800A, 3-phase (external CTs required)
Power Consumption	10 Watts (max.)
Output Contact Rating SPDT (Form C)	Pilot duty rating: 480VA @ 240VAC General purpose: 10A @ 240VAC (470 VA @ 600 VAC Pilot duty for 777-HVR-P*****)
Expected Life	
Mechanical	1 x 10 ⁶ operations
Electrical	1 x 10 ⁵ operations at rated load
Accuracy at 25° C (77° F)	
Voltage	±1%
Current	±3%(<100A Direct)
GF Current	±15%
Timing	5% ±1 second
Repeatability	
Voltage	±0.5% of nominal voltage
Current	±1% (<100A direct)
Trip Times (Those not shown have user selectable trip times.)	
<u>Ground Fault Trip Time</u> 101%-200% of Setpoint 201%-300% of Setpoint 301%-400% of Setpoint 401% or Greater	<u>Trip time:</u> 8 seconds ±1 second 4 seconds ±1 second 3 seconds ±1 second 2 seconds ±1 second
<u>Current Unbalance Trip Times</u> % Over Setpoint 1% 2% 3% 4% 5% 6% 10% 15%	<u>Trip time</u> 30 seconds 15 seconds 10 seconds 7.5 seconds 6 seconds 5 seconds 3 seconds 2 seconds
Safety Marks	
UL	UL508, UL1053
CE	IEC 60947-1, IEC 60947-5-1
Standards Passed	
Electrostatic Discharge (ESD) Radio Frequency Immunity (RFI), Conducted Radio Frequency Immunity (RFI), Radiated	IEC 1000-4-2, Level 3, 6kV contact, 8kV air IEC 1000-4-6, Level 3 10V IEC 1000-4-3, Level 3 10V/m
Fast Transient Burst	IEC 1000-4-4, Level 3, 3.5 kV input power
Surge	
IEC	1000-4-5 Level 3, 2kV line-to-line; Level 4, 4kV line-to-ground

ANSI/IEEE	C62.41 Surge and Ring Wave Compliance to a level of 6kV line-to-line
Hi-potential Test	Meets UL508 (2 x rated V +1000V for 1 minute)
Vibration	IEC 68-2-6, 10-55Hz, 1mm peak-to-peak, 2 hours, 3 axis
Shock	IEC 68-2-27, 30g, 3 axis, 11ms duration, half-sine pulse
Mechanical	
Dimensions	3.0"H x 5.1"D x 3.6"W
Terminal Torque	7 in.-lbs.
Enclosure Material	Polycarbonate
Weight	1.2 lbs
Max. Conductor Size Through 777-P	0.65" with insulation
Environmental	
Temperature Range	Ambient Operating: -20° to 70° C (-4° to 158°F) Ambient Storage: -40° to 80° C (-40° to 176°F)
Pollution Degree	3
Class of Protection	IP20, NEMA 1
Relative Humidity	10-95%, non-condensing per IEC 68-2-3
Programmable Operating Points	
	Range
LV- Low Voltage Threshold	170-524V (450-649V*) (340-523V****)
HV- High Voltage Threshold	172-528V (451-660V*) (341-528V****)
VUB- Voltage Unbalance Threshold	2-15% or 999 (disabled)
MULT- # of Conductors or CT Ratio (XXX:5)	1-10, 100, 150, 200, 300, 400, 500, 600, 700, 800
OC- Overcurrent Threshold	(20-100A) ÷ MULT or 80-140% of CT Primary
UC- Undercurrent Threshold	(0, 10-98A) ÷ MULT or 40-140% of CT Primary
CUB- Current Unbalance Threshold	2-25% or 999 (disabled)
TC- Overcurrent Trip Class ** and Linear Overcurrent Trip Delay	02-30, J02-J30
	L00-L60 or OFF
RD1- Rapid Cycle Timer	0-500 seconds (standard)
RD2- Restart Delay After All Faults Except Undercurrent (motor cool-down timer)	2-500 minutes (standard)
RD3- Restart Delay After Undercurrent (dry-well recovery timer)	2-500 minutes (standard), A (automatic)
#RU- Number of Restarts After Undercurrent	0, 1, 2, 3, 4, A (automatic)
ADDR- RS485 Address	A01-A99
#RF-Number of Restarts After All Faults Except Undercurrent	*** 0, 1, oc1, 2, oc2, 3, oc3, 4, oc4, A, ocA
UCTD- Undercurrent Trip Delay	2-255 seconds (standard)
GF- Ground Fault Current Threshold	(3-20A) ÷ MULT or 12-80% of CT Primary or OFF

NOTES: SymCom's Overload Relay can be programmed prior to installation by applying 120VAC between the L1 and L2 terminals (except 575 volt model).

* 575 volt model.

** If a "J" is included in the trip class (TC) setting, jam protection is enabled.

*** If "oc" is displayed in the #RF setting, the 777-P will automatically restart (after RD2 expires) following an overcurrent fault in addition to single-phasing and current unbalance faults. Otherwise, a manual reset is required after an overcurrent fault.

**** HVR model

Setpoints for address 127

```

-----
LV:                200 Volts
HV:                500 Volts
VUB:              6 %
Multiplier:       1
Divisor:          1
OC:               60.0 Amps
UC:               35.0 Amps
CUB:              7 %
TC:               10
RD1:              10 Seconds
RD2:              8 Minutes
RD3:              20 Minutes
#RU:              1
#RF:              OC1
UCTD:             5 Seconds
GF:               10.00 Amps
MB Address:       12
Network Status:   00000000
ComParam:         011
Enable/Disable:  00001111
Motor Run Hours:  0
Low Control Voltage Delay: 2 Seconds
Low Control Voltage Percentage: 80 %
cfgCtrl:          0000000000001111
Lin OC:           Off Seconds
CUB TD:           60
MACtrl:           000000000000
MATD:             0.0 Seconds
Start Count Upper: 0 Starts
Start Count:      3 Starts
StartDur1 Upper:  0 minutes
StartDur1:        3 minutes
StartDur1 Upper:  0 minutes
StartDur2:        0 minutes
StartDur3 Upper:  0 minutes
StartDur3:        13 minutes
StartDur4 Upper:  0 minutes
StartDur4:        0 minutes
HotOCPer:         100 %
Command Line:     0
Backdoor Address: 127
MBAssem500Wrd1:  2
MBAssem500Wrd2:  3
MBAssem500Wrd3:  4
MBAssem500Wrd4:  5
MBAssem500Wrd5:  6
MBAssem500Wrd6:  7
MBAssem500Wrd7:  8
MBAssem500Wrd8:  9
MBAssem500Wrd9:  10
MBAssem500Wrd10: 11
MBAssem500Wrd11: 12
MBAssem500Wrd12: 13
MBAssem500Wrd13: 14
MBAssem500Wrd14: 15

```

MBAssem500Wrd15:	16
MBAssem500Wrd16:	17
MBAssem500Wrd17:	18
MBAssem500Wrd18:	19
MBAssem500Wrd19:	20
MBAssem500Wrd20:	21
MBAssem500Wrd21:	22
MBAssem500Wrd22:	23
MBAssem500Wrd23:	26
MBAssem500Wrd24:	27
MBAssem500Wrd25:	28
MBAssem500Wrd26:	29
MBAssem500Wrd27:	30
MBAssem500Wrd28:	31
MBAssem500Wrd29:	102
MBAssem500Wrd30:	103
MBAssem500Wrd31:	104
MBAssem500Wrd32:	105
MBAssem500Wrd33:	106
MBAssem500Wrd34:	107
MBAssem500Wrd35:	108
MBAssem500Wrd36:	109
MBAssem500Wrd37:	110
MBAssem501Wrd1:	111
MBAssem501Wrd2:	112
MBAssem501Wrd3:	113
MBAssem501Wrd4:	114
MBAssem501Wrd5:	115
MBAssem501Wrd6:	116
MBAssem501Wrd7:	117
MBAssem501Wrd8:	118
MBAssem501Wrd9:	119
MBAssem501Wrd10:	122
MBAssem501Wrd11:	123
MBAssem501Wrd12:	124
MBAssem501Wrd13:	125
MBAssem501Wrd14:	126
MBAssem501Wrd15:	127
MBAssem501Wrd16:	128
MBAssem501Wrd17:	129
MBAssem501Wrd18:	130
MBAssem501Wrd19:	131
MBAssem501Wrd20:	132
MBAssem501Wrd21:	133
MBAssem501Wrd22:	134
MBAssem501Wrd23:	135

Real-time parameters for address 127

Line Voltage L1-L3:	***
Line Voltage L2-L3:	***
Line Voltage L3-L1:	***
Average Voltage:	***
Current in Phase A:	***
Current in Phase B:	***
Current in Phase C:	***

Average Current:	***
Voltage Unbalance:	***
Current Unbalance:	***
Scale Factor:	***
Power Factor:	***
Power Factor Angle:	***
Ground Fault Current:	***
RD1 Remaining:	***
RD2 Remaining:	***
RD3 Remaining:	***
Power:	***
Power:	***
Trip Reason:	***
Overload Status:	***
Last Fault 1:	***
Last Fault 2:	***
Last Fault 3:	***
Last Fault 4:	***
Unit ID:	***
Model Code:	***
Software Rev:	***
Thermal Capacity:	***
Start Count:	*** Starts
Start Dur 1:	*** Minutes
Start Dur 2:	*** Minutes
Start Dur 3:	*** Minutes
Start Dur 4:	*** Minutes