

Product information presented here reflects conditions at time of publication. Consult factory regarding discrepancies or inconsistencies.



PUMP COMPANY

Zoeller Family of Water Solutions™

MAIL TO: P.O. BOX 16347 • Louisville, KY 40256-0347
 SHIP TO: 3649 Cane Run Road • Louisville, KY 40211-1961
 (502) 778-2731 • 1 (800) 928-PUMP • FAX (502) 774-3624

visit our web site:
www.zoeller.com

SPECIFICATIONS

SEWAGE/SUMP SIMPLEX SYSTEM

ZOELLER COMPANY SUBMERSIBLE SEWAGE OR DEWATERING PUMPS

SINGLE SEAL	264	266	267	268	270	282	284	292	293	294	295	404	405
DOUBLE SEAL					4270	4282	4284	4292	4293	4294	4295	4404	4405

CAST IRON SERIES SIMPLEX SYSTEM

Furnish a Zoeller nonautomatic submersible pump(s), Model _____ Single Seal or Model _____ Double Seal, _____ a simplex control panel or _____ a combination starter. Pumps shall have a capacity of _____ GPM against a Total Dynamic Head of _____ feet. Motor specification: _____ voltage, _____ cycle, _____ phase, _____ HP. Discharge to be _____ 2" or _____ 3" NPT or _____ 4" flange (404/4404, 405/4405). Cord length to be _____ feet. Pump shall be mounted on rail system with NPT _____ or flange _____ discharge. Pumps will pass _____ 2" Solids (264, 266, 267, 268, 270/4270, 282/4282, 284/4284, 292/4292, 293/4293, 294/4294, 295, 4295), or _____ 3" Solids (404/4404, 405/4405). Pumps shall be UL listed, _____ CSA approved, _____ SSPMA certified, _____ State of Wisc. approved, _____ other (Specify _____).

SINGLE PHASE SYSTEM

GENERAL

Pump motor shall be hermetically sealed, submersible type, operating in a high quality dielectric oil for cooling the windings and for lubrication of the motor bearings and ceramic-carbon shaft seal. Single phase motor shall have internal automatically resetting, thermal overload protection. Construction shall be of cast iron with 100% baked-on powder coated epoxy finish for corrosion resistance and longer casting durability. All fasteners and external metal parts shall be of stainless steel. Impeller shall be of vortex non-clog design. (Addition noted below.)

Check Applicable Series:

- _____ 264 (.4 HP) model pump shall have P.S.C. motor. Cast iron switch case, motor housing and pump housing with plastic impeller and base.
- _____ 266 (1/2 HP) model pump shall have split phase motor with current sensing, starting relay enclosed in switch housing. Cast iron switch case, motor housing and pump housing with plastic impeller and base.
- _____ 267 (1/2 HP) model pump shall have split phase motor with current sensing, starting relay enclosed in switch housing.
- _____ 268 (1/2 HP) model pump shall have split phase motor with current sensing, starting relay enclosed in switch housing. Discharge shall have a permanently affixed 2" female - 3" male combination discharge hub.
- _____ 270 (1 HP) cast iron series pump shall have a permanent split capacitor motor with capacitor enclosed in the upper housing attached to the pump. The impeller shall be cast bronze. Motor housing shall be cast iron.
- _____ 4270 (1HP) cast iron series pump with double car-

bon/ ceramic shaft seals shall have a permanent split capacitor motor with capacitor enclosed in the upper housing attached to the pump. The impeller shall be cast bronze. Motor housing shall be cast iron. The lower seal cavity shall be oil filled.

_____ 282 (½ HP) cast iron series pump shall have a permanent split capacitor motor with run capacitor enclosed in the upper housing attached to the pump. Impeller and motor housing shall be cast iron. The motor housing shall be finned for extra cooling capability.

_____ 284 (1 HP) cast iron series pump shall have a permanent split capacitor motor with run capacitor and, on automatic units, a magnetic contactor enclosed in the upper housing attached to the pump. Impeller and motor housing shall be cast iron. The motor housing shall be finned for extra cooling capability.

_____ 4282 (½ HP) _____ 4284 (1 HP) cast iron series pump with double carbon/ceramic shaft seals shall have a permanent split capacitor motor with run capacitor enclosed in the upper housing attached to the pump. Impeller and motor housing shall be cast iron. The motor housing shall be finned for extra cooling capability. The lower seal cavity shall be oil filled.

_____ 292 (½ HP) _____ 293 (1 HP) _____ 294 (1½ HP) _____ 295 (2 HP) cast iron series pump shall have a permanent split capacitor motor with capacitor and, on automatic units, a magnetic contactor enclosed in the upper housing attached to the pump. The impeller shall be cast bronze. Motor housing shall be cast iron and finned for extra cooling capability.

_____ 4292 (½ HP) _____ 4293 (1 HP) _____ 4294 (1½ HP) _____ 4295 (2 HP) cast iron series pump with double carbon/ceramic shaft seals shall have a permanent split capacitor motor with capacitor enclosed in the upper housing attached to the pump. The impeller shall be cast bronze. Motor housing shall be cast iron and finned for extra cooling capability. The lower seal cavity shall be oil filled.

_____ 404 (2 HP) _____ 405 (3 HP) cast iron series pump shall have a permanent split capacitor motor with capacitor enclosed in the upper housing attached to the pump. Impeller and motor housing shall be cast iron. The motor housing shall be finned for extra cooling capability.

_____ 4404 (2 HP) _____ 4405 (3 HP) cast iron series pump with double carbon/ceramic shaft seals shall have a permanent split capacitor motor with capacitor enclosed in the upper housing attached to the pump. The impeller and motor housing shall be cast iron. The motor housing shall be finned for extra cooling capability. The lower seal cavity shall be oil filled.

AUTOMATIC CONTROL-INTEGRAL FLOAT TYPE

Single phase pump shall have an integral mechanical float switch which shall require no adjustment, nor require additional equipment for operation.

AUTOMATIC CONTROL PIGGYBACK VARIABLE LEVEL FLOAT SWITCH

A Zoeller _____ Piggyback Variable Level Float Switch with a fifteen (15) foot SJOWA cord and molded plug shall be furnished to control a nonautomatic pump. Control shall be constructed of durable plastic and be omnidirectional. Control shall be fastened to discharge pipe with plastic tie mounting strap and shall require no extra wiring. (Addition noted below).

Check Applicable Control:

_____ 10-0032 (115V/Max. 15 Amps), _____ 10-0033 (230V/Max. 15 Amps), _____ 10-0034 (115V/Max. 13 Amps), or _____ 10-0035 (230V/Max. 13 Amps) (For use on 115V or 230V, 1 phase nonautomatic Zoeller pump). Designed for automatic pump operation with appropriate voltage and horsepower, single phase, Zoeller pump.

_____ 10-0229 (115V/Max. 1 HP) or _____ 10-0230 (230V/Max. 2 HP) (For use on 115V or 230V, 1 phase, nonautomatic Zoeller pump.) Double float system shall have an adjustable pumping range. Pumping range shall be a minimum of one (1) inch to a maximum of forty-eight (48) inches.

SIMPLEX CONTROL PANEL

A Zoeller _____ Simplex Control Panel shall be furnished to control a nonautomatic pump. The panel shall have a Nema 4x enclosure, pump run indicator lights, high water alarm, selector switches, float switches, and UL label.

_____ 10-0123 120V/1PH and 15 max. amps.

_____ 10-0124 208-230V/1PH and 15 max. amps.

_____ 10-0323 115-208-230V/1PH and 15 max. amps.

_____ 10-0125 115-208-230V/1PH and 20 max. amps.

THREE PHASE SYSTEM - FOR USE WITH 3 PHASE PUMPS

GENERAL

Pump motor shall be hermetically sealed, submersible type, operating in a high quality dielectric oil for cooling the windings and for lubrication of the motor bearings and ceramic-carbon shaft seal. Pump motor shall have external magnetic contactor and overload protection. All fasteners and external metal parts shall be of stainless steel. Impeller shall be of vortex non-clog design. (Addition noted below).

_____ 266 (½ HP) _____ 267 (½ HP) _____ 268 (½ HP) Series shall have a 4-pole squirrel cage induction motor.

_____ 282 (½ HP) _____ 284 (1 HP) Series shall have a 4-pole squirrel cage induction-motor. The motor housing shall be finned for extra cooling capability.

_____ 4282 (½ HP) _____ 4284 (1 HP) cast iron series pump with double carbon/ceramic shaft seals shall have a 4-pole squirrel cage induction motor. Impeller and motor housing shall be cast iron. The motor housing shall be finned for extra cooling capability. The lower seal cavity shall be oil-filled.

_____ 293 (1 HP) _____ 294 (1½ HP) _____ 295 (2 HP) Series shall have a 2-pole squirrel cage induction motor. Impeller shall be of cast bronze. The motor housing shall be finned for extra cooling capability.

_____ 4293 (1 HP) _____ 4294 (1½ HP) _____ 4295 (2 HP) cast iron series pump with double carbon/ceramic shaft seals shall have 2-pole squirrel cage induction motor. The impeller shall be cast bronze. Motor housing shall be cast iron and finned for extra cooling capability. The lower seal cavity shall be oil-filled.

_____ 404 (2 HP) _____ 405 (3 HP) series shall have a 4-pole squirrel cage induction motor. Impeller and motor housing shall be cast iron. The motor housing shall be finned for extra cooling capability.

_____ 4404 (2 HP) _____ 4405 (3 HP) cast iron series pump with double carbon/ceramic shaft seals shall have 4-pole squirrel cage induction motor. Impeller and motor housing shall be cast iron. The motor housing shall be finned for extra cooling capability. The lower seal cavity shall be oil-filled.

SIMPLEX CONTROL PANEL

A Zoeller _____ Simplex Control Panel with three 10-0225 Control Switches shall be furnished to control a nonautomatic pump. The panel shall have a Nema 4X enclosure, pump run indicator light, high water alarm, selector switches, and a UL label. Panel will be sized for Zoeller Model _____, _____ Volt, _____ Cycle, _____ Phase, _____ HP, _____ FLA pump.

CONTROL SWITCHES

A Zoeller Variable Level Float Switch shall be furnished to operate control circuit. Float shall be omnidirectional and include a fifteen (15) foot SJOWA cord and plastic tie mounting strap.

ACCESSORIES/MISCELLANEOUS

UNICHECK

- _____ 30-0021 (Clamp union valve) (2 inch) full flow check valve, rated at 4.3 psi (10 feet TDH) at 130° deg. F. shall be furnished to fit 2 inch ABS, PVC, CPVC, steel or copper piping. Unicheck shall have valve body and seat of PVC plastic and shall be assembled with stainless steel thru bolts. Gasket and flapper shall be neoprene with brass or stainless steel backing plates. Unicheck shall include two (2) neoprene unions and four (4) stainless steel clamps and fasteners.
- _____ 30-0151 (Clamp Union Valve) 2 inch full flow check valve. Rated at 4.3 psi (10 feet TDH) at 130° F. and shall be furnished to fit 2 inch ABS, PVC, CPVC, steel or copper piping. Valve body and seat shall be of cast iron. Gasket and flapper shall be neoprene with brass backing plates and stainless steel rivet. Unicheck shall include two (2) neoprene unions and four (4) stainless steel clamps and fasteners.
- _____ 30-0020 (2 inch) or _____ 30-0030 (3 inch) IPS full flow compression union check valve shall be furnished. Unicheck body and compression end fittings shall be constructed of PVC. Flapper and end seals shall be Buna-N. Valve shall include no metallic parts. Pressure rated at 4.3 PSI (10 feet TDH) at 130° F.
- _____ 30-0152 (2 inch) or _____ 30-0160 (3 inch) cast iron full flow check valve with female N.P.T. Rated at 50 PSI (115 feet TDH) at 130° F. Neoprene polyester reinforced flapper with cast iron and brass backing plates and stainless steel fastener.
- _____ 30-0170 (4 inch) Flanged cast iron check valve. Rated at 125 PSI steam pressure. Cast iron body, cover and case, bronze disc, stainless steel fitted, shall be installed in horizontal position.
- _____ Tri-Check/Combo, 30-0101 or 30-0103.

OPTIONAL ALARM SYSTEM

An audible high water alarm system shall include a Zoeller

- _____ 10-0015 (115V) or _____ 10-0016 (230V) A-Pak and a 10-0225 Variable Level Float Switch. The A-Pak shall include a six (6) inch steel alarm bell, which shall sound sixty-eight (68) decibels at a distance of ten (10) feet and a dual mount transformer, which shall step down 115V or 230V 1 PH line voltage to 8V. The 10-0225 Variable Level Float Switch shall be constructed of plastic and shall be omnidirectional. Float shall include fifteen (15) foot SJOWA cord and shall be fastened to discharge pipe with plastic tie mounting strap.
- _____ 10-0053 (115V/1Ph) A-Pak complete with sensor float and Nema 1 metal enclosure (cord and plug). Solid state warning light and horn, which can be manually turned off. UL listed and CSA certified on complete alarm system.
- _____ 10-0126 (115V/1Ph) High level Alarm complete with Nema 4x enclosure, alarm bell, Alarm light, Silence switch, and sensor float switch with 15' cord. Entire unit is UL Listed and CSA Certified.
- _____ 10-0623 (115V/IPH) High Level Alarm rated for Indoor/Outdoor use per UL 864. The alarm will include an alarm horn, alarm light, silence and test buttons, and a 15' float switch.

- _____ 10-0682 (115V/1Ph) deluxe high-level alarm rated for indoor/outdoor use per UL 864. The alarm will include an alarm horn, alarm light, silence and test buttons, a 20' float switch, 6' power cord, and watertight connectors.

SUMP BASIN

A Zoeller IAPMO approved _____ polyethylene basin, .200 inch thick, .949 G/CC dense, or Zoeller _____ fiberglass basin, 3/16" inch thick, .058 pounds/cubic feet dense, _____ inches inside diameter by _____ inches deep shall be furnished. The basin shall include _____ four (4) inch cast-iron caulk hub inlets with anticorrosion coating. The center line of the hub(s) shall be located nine (9) inches from the top of the basin. The basin shall also include a .115 inch thick steel sump cover. An optional pump installation plate can be provided on covers twenty-four (24) inches in diameter or larger. Optional antifloatation ring can also be provided. Also included shall be a neoprene seal for pump cord, neoprene seal for vent and discharge flange, foam cover seal and plated steel fasteners. Cover shall include a _____ inch vent and a _____ inch discharge flange with mounting hardware.

PIPING & POWER WIRING

All piping shall be rigid and permanent in nature and shall be furnished and installed by the contractor. A unicheck shall be installed in the discharge pipe. A 3/16" vent hole shall be drilled in the discharge pipe below the check valve and pit cover to purge the system of trapped air. Power wiring shall be supplied by the electrical contractor. Power wiring for pumping system and alarm system shall be connected to separate circuits.

EXTRA DUTY

Where conditions require, specify extra duty for adverse operating conditions.

HIGH TEMPERATURE PUMPS

For application up to 200° F. operation, specify High Temperature Zoeller Co. models. See literature on High Temperature pumps, FM0806 and FM0807, for additional information. For 200° F. specification sheet, see FM0817.

PUMP DISCONNECTS AND RAIL SYSTEMS

Where conditions, due to safety, health and the economy of maintenance require pump disconnects or rail systems specify:

- _____ 39-0002, 2" Disconnect (Non-pump Supporting)
_____ 39-0004, 2" NPT Rail System (Non-pump Supporting)
_____ 39-0083, 2" NPT Galv. Ez Out (Pump Supporting)
_____ 39-0084, 2" NPT S.S. Ez Out (Pump Supporting)
_____ 39-0074, 3" NPT Galv. Ez Out (Pump Supporting)
_____ 39-0075, 3" NPT S.S. Ez Out (Pump Supporting)
_____ 39-0073, 4" Flanged Rail System Carbon Steel Fitted (Pump Supporting)
_____ 39-0016, 4" Flanged Rail System Stainless Steel Fitted (Pump Supporting)

Square Guide Rail Systems shall include single rigid stainless steel square rail design, red brass disconnect fitting, cast iron angle arm bracket and guide plates. _____ Galvanized or _____ stainless piping, PVC ball valve, cast iron check valve. Rail system shall be for a Zoeller Model _____ with a _____ inch discharge. Rail system will be for a _____ inch diameter basin.

**SEWAGE SIMPLEX SYSTEM WITH INTEGRAL SWITCH
(SINGLE PHASE)**

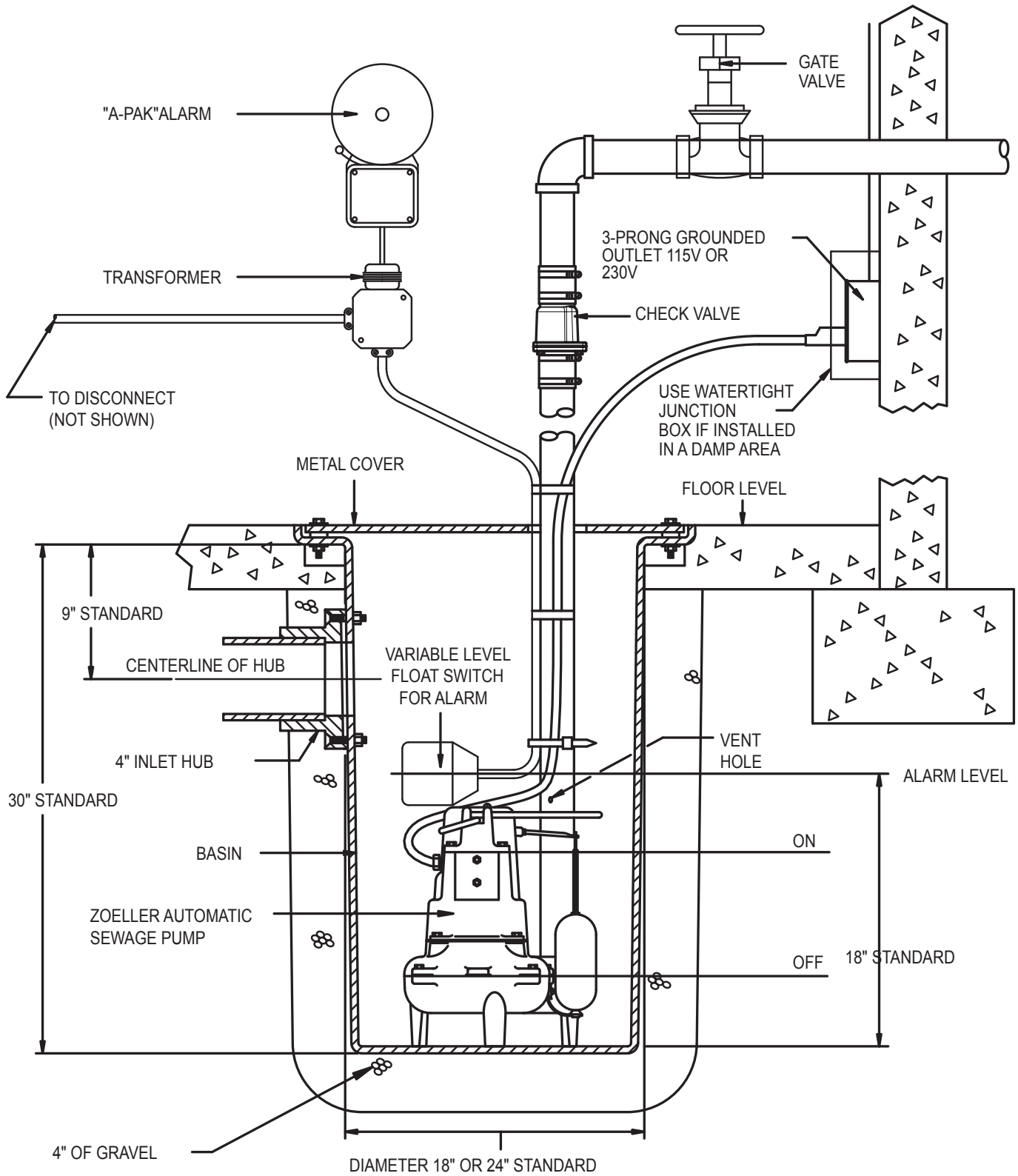

SK1431

**SEWAGE SIMPLEX SYSTEM WITH SINGLE PIGGYBACK VARIABLE LEVEL FLOAT SWITCH
(SINGLE OR THREE PHASE)**

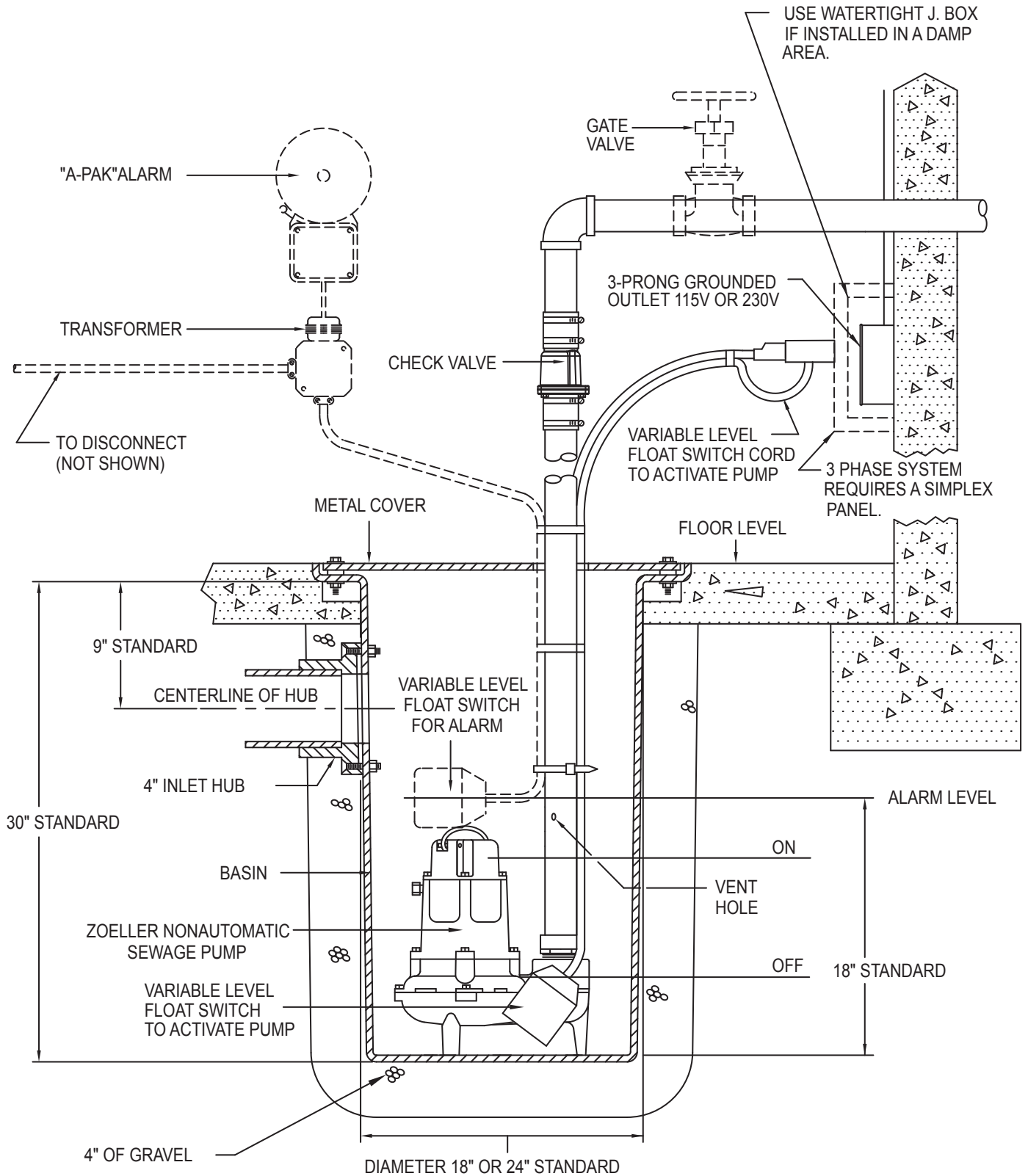

SK1432

PUMP DISCONNECT WITH RAIL SYSTEM

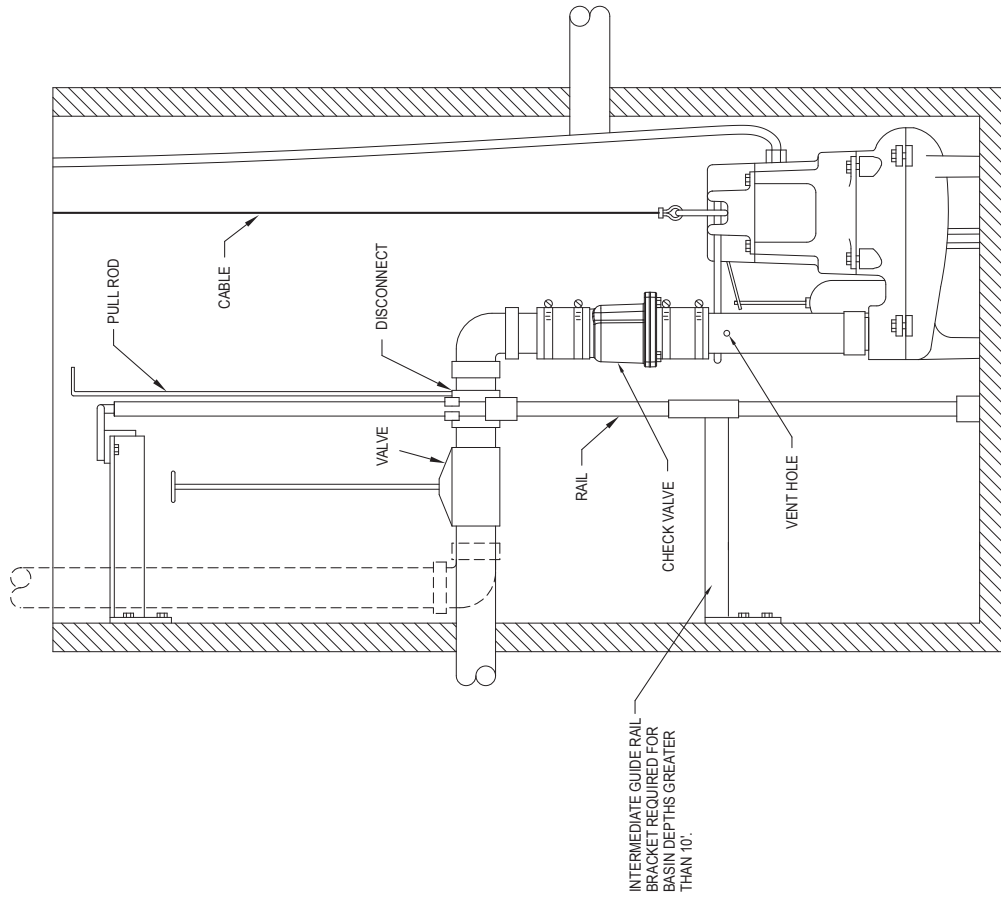

SK1735

PUMP DISCONNECT SYSTEM

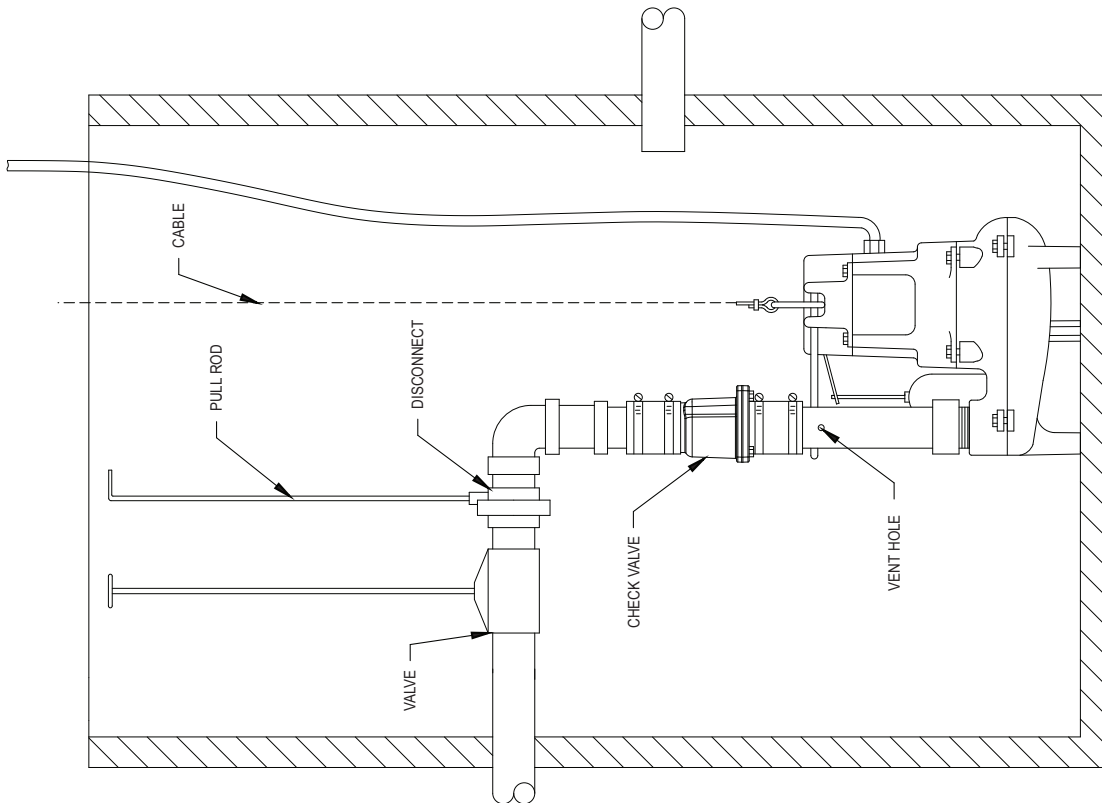

SK1531

SQUARE GUIDE RAIL SYSTEM WITH DESCRIPTIONS

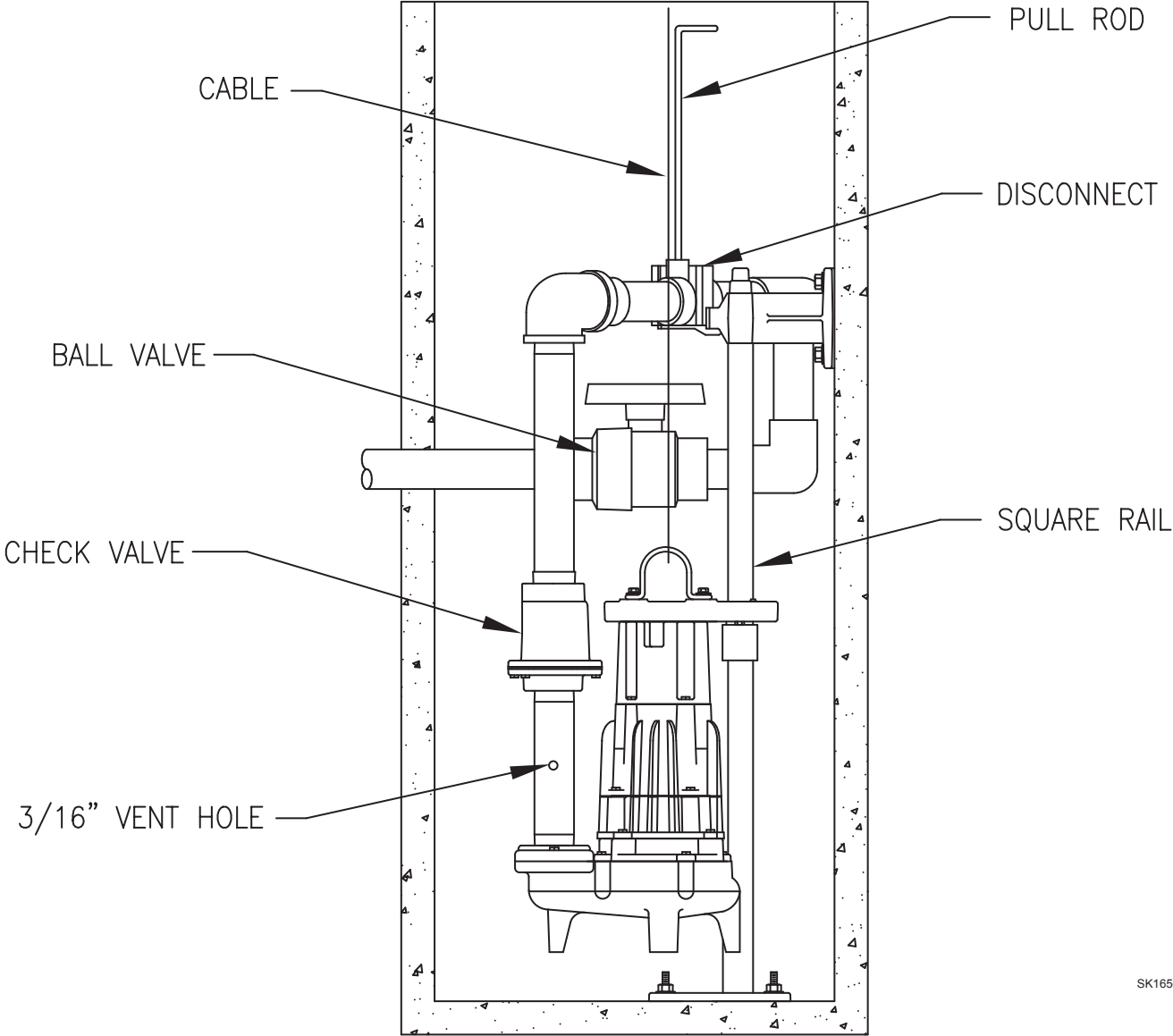
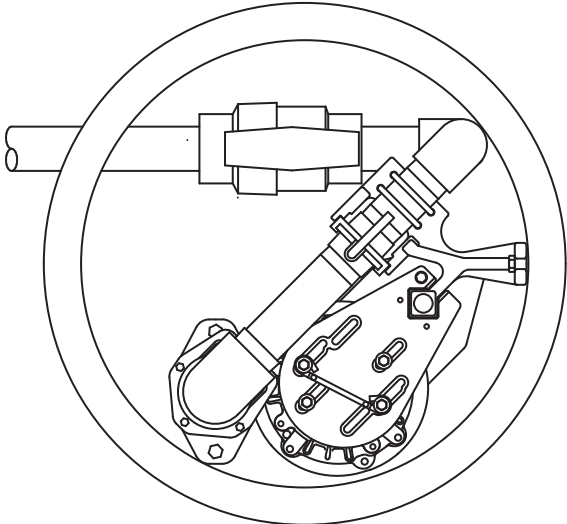

SK1650

404/4404/405/4405 OR SEWAGE/WASTE GUIDE RAIL SYSTEMS

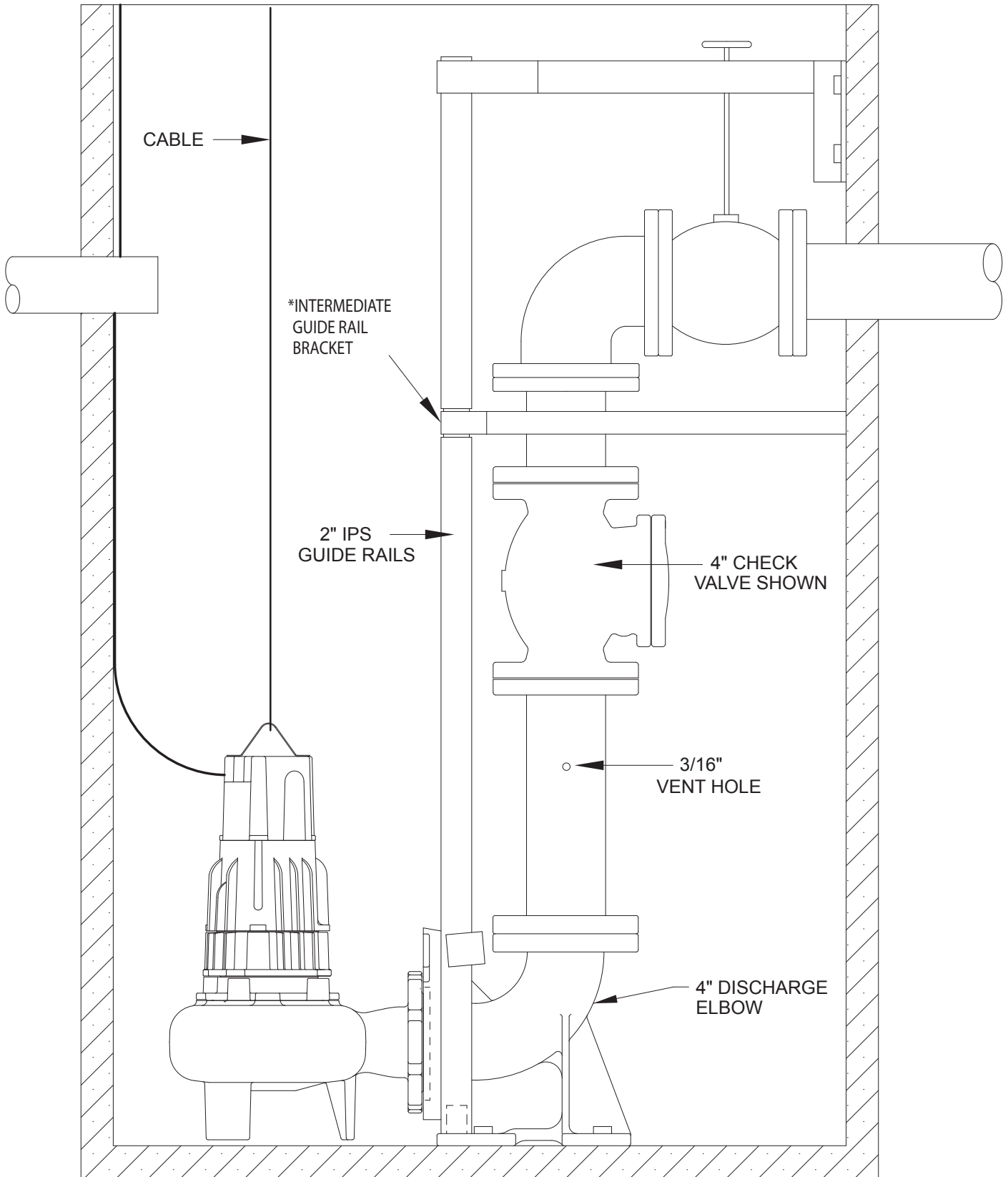

SK1100