

Product information presented here reflects conditions at time of publication. Consult factory regarding discrepancies or inconsistencies.



TECHNICAL DATA SHEET SEWAGE WASTE SERIES *Models 810, 815 Progressing Cavity Grinder Pumps*

PRODUCT SPECIFICATIONS

MOTOR	Horse Power	1 (810), 2 (815)
	Voltage	230
	Phase	1 Ph
	Hertz	60 Hz
	RPM	1725
	Type	Permanent split capacitor
	Insulation	Class B
	Amps	7.0 (810), 10.5 (815)
PUMP	Operation	Nonautomatic
	Discharge Size	1-1/4" NPT horizontal
	Cord Length	20' (6 m) standard
	Cord Type	SOW or SOOW, multi-wire neoprene
	Max. Head	810: 150' (45.7 m), 815: 240' (73.2 m)
	Max. Flow Rate	14.6 GPM (55 LPM)
	Max. Operating Temp.	130°F (54°C)
	Motor Protection	Auto reset thermal overload
MATERIALS	Cap	Cast iron
	Motor Housing	Cast iron
	Adapter	Cast iron
	Pump Housing	Cast iron
	Upper Bearing	Ball bearing
	Lower Bearing	Ball bearing
	Mechanical Seals	Carbon/ceramic
	Hydraulic Rotor	Stainless steel
	Hydraulic Stator	Buna-N
	Hardware	Stainless steel
	Motor Shaft	Stainless steel
	Gasket & Square Ring	Neoprene
	Cutter	Hardened stainless steel, Rockwell C55-60

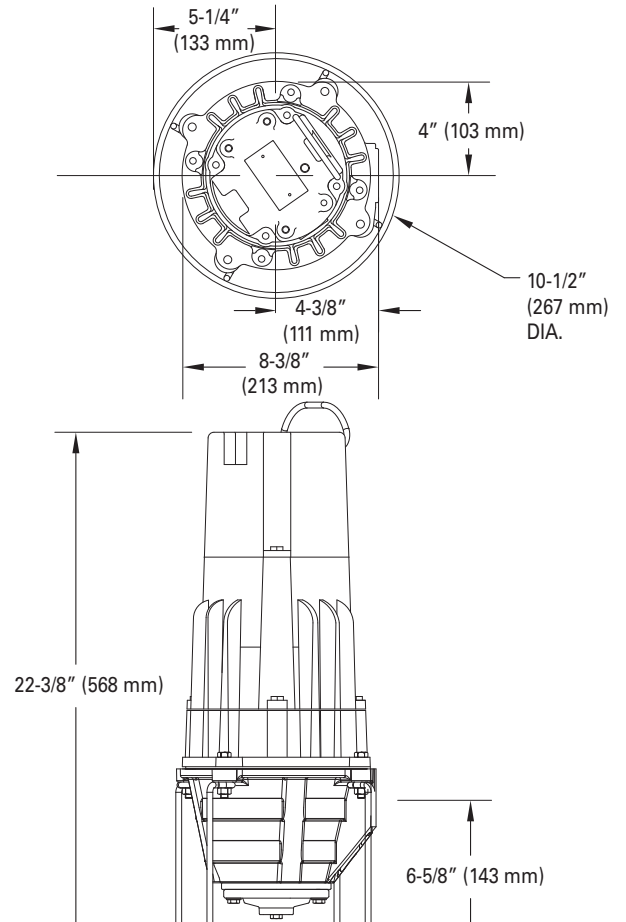

SK2533

NOTE: See model comparison chart for specific details.



**TOTAL DYNAMIC HEAD
FLOW PER MINUTE**

	Feet	Meters	Gal.	Liters
MODEL 810	5	1.5	14.6	55
	10	3.0	14.4	55
	20	6.1	14.0	53
	40	12.2	13.2	50
	60	18.3	12.5	47
	80	24.4	11.7	44
	100	30.5	10.9	41
	120	36.6	10.1	38
	140	42.7	9.4	36
	150	45.7	9.0	34
MODEL 815	160	48.8	8.6	33
	180	54.9	7.8	30
	200	61.0	7.0	27
	220	67.1	6.3	24
	240	73.2	5.5	21

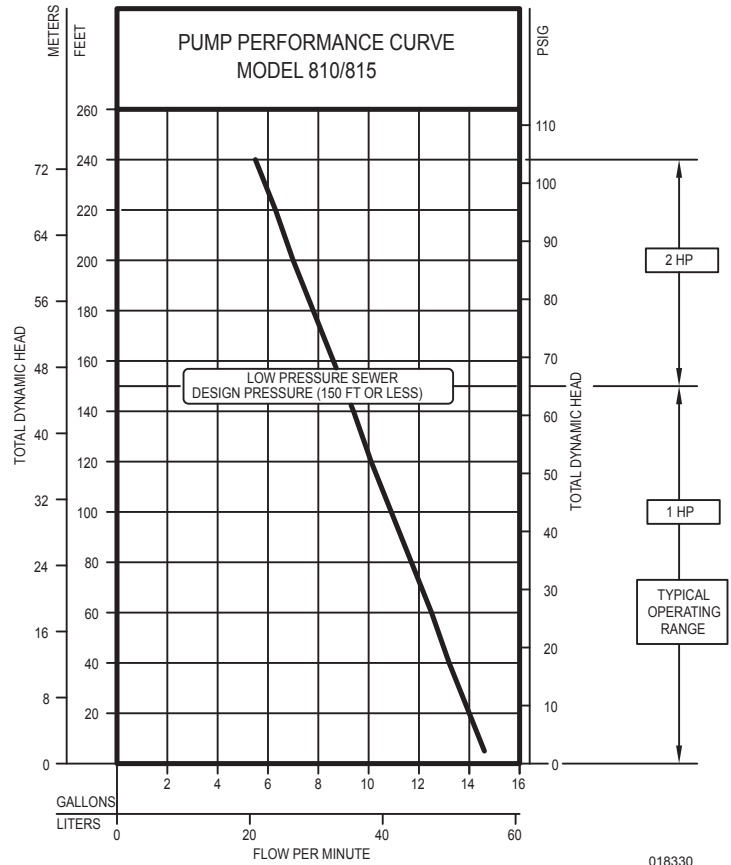

Model	MODEL COMPARISON								
	Seal	Mode	Volts	Ph	Amps	HP	Hz	Lbs	Kg
E810	Single	Non	230	1	7.0	1	60	88	40
E815	Single	Non	230	1	10.5	2	60	91	41

CAUTION All installation of controls, protection devices and wiring should be done by a qualified licensed electrician. All electrical and safety codes should be followed including the most recent National Electrical Code (NEC) and the Occupational Safety and Health Act (OSHA).

A) GRINDER SYSTEMS

STANDARD FEATURES:

- 1-1/4" NPT discharge
- Carbon/ceramic tandem seals
- Thermal overload protection
- Hydraulic stainless steel rotor and Buna-N stator
- Stainless steel cutter plate / cutter
- Stainless steel shaft
- Stainless steel hardware
- Corrosion-resistant, powder coated epoxy paint
- 20' (6 m) Power cord cord

Options:

- 25' (8 m) Long cords
- 35' (11 m) Long cords
- 50' (15 m) Long cords

CAUTION To ensure proper pump operation, a swing or flapper style check valve must be installed in the pump discharge line. A faulty or non-functional check valve when combined with a pressure sewer may prevent the pump from starting.

Maximum operating temperature 130°F (54°C).

Note: All variable level float switches in this section are mechanically activated and do not contain mercury.

QWIK BOX w/ FLOAT SWITCH
<p>B) ALARM PANEL</p> <ul style="list-style-type: none"> <input type="checkbox"/> P/N 10-0623 Indoor/Outdoor high water alarm with 15' (5 m) control switch. <input type="checkbox"/> P/N 10-0126 NEMA 4X high water alarm with 15' (5m) control switch and dry contact. <input type="checkbox"/> P/N 10-4012 Indoor high water alarm with 15' (5m) control switch.
<p>C) PUMP SWITCH AND WEIGHT - 1 pump switch required</p> <p>Single piggy-back type 230 volt 13 amp</p> <ul style="list-style-type: none"> <input type="checkbox"/> P/N 10-0035 with 15' (5 m) cord <input type="checkbox"/> P/N 10-0689 weight for alarm float (Indoor systems only)
<p>D) JUNCTION BOX - 1 required</p> <ul style="list-style-type: none"> <input type="checkbox"/> P/N 10-0580 Qwik-Box, NEMA 4X with 230 volt receptacle

PLUGGER PANEL
<p>B) CONTROL PANEL</p> <ul style="list-style-type: none"> <input type="checkbox"/> P/N 10-2006 Plugger panel, NEMA 4X with high water alarm and 230 volt receptacle.
<p>C) FLOAT SWITCHES - 2 required</p> <p>Pump: One pump switch Alarm: One control switch</p> <ul style="list-style-type: none"> <input type="checkbox"/> P/N 10-0706 piggy-back pump switch with 20' (6 m) cord <input type="checkbox"/> P/N 10-0311 piggy-back pump switch with 25' (8 m) cord <input type="checkbox"/> P/N 10-1956 piggy-back pump switch with 35' (11 m) cord <input type="checkbox"/> P/N 10-0744 mechanical control switch with 20' (6 m) cord <input type="checkbox"/> P/N 10-1877 mechanical control switch with 25' (8 m) cord <input type="checkbox"/> P/N 10-1878 mechanical control switch with 35' (11 m) cord
<p>D) JUNCTION BOX</p> <p>J-Box not recommended with this type control.</p>

SIMPLEX PANEL
<p>B) CONTROL PANEL</p> <ul style="list-style-type: none"> <input type="checkbox"/> P/N 10-1212 Simplex panel, NEMA 4X, with high water alarm and pump circuit breaker, less float switches.
<p>C) FLOAT SWITCHES - 2 required</p> <p>Pump: One pump switch Alarm: One control switch</p> <ul style="list-style-type: none"> <input type="checkbox"/> P/N 10-0706 piggy-back pump switch with 20' (6 m) cord <input type="checkbox"/> P/N 10-0311 piggy-back pump switch with 25' (8 m) cord <input type="checkbox"/> P/N 10-1956 piggy-back pump switch with 35' (11 m) cord <input type="checkbox"/> P/N 10-0744 mechanical control switch with 20' (6 m) cord <input type="checkbox"/> P/N 10-1877 mechanical control switch with 25' (8 m) cord <input type="checkbox"/> P/N 10-1878 mechanical control switch with 35' (11 m) cord
<p>D) JUNCTION BOX - optional</p> <ul style="list-style-type: none"> <input type="checkbox"/> P/N 10-2145 NEMA 4X with 3 cord seals and conduit connection.

INDOOR AND OUTDOOR PACKAGED SYSTEMS - PUMP AND CONTROLS NOT INCLUDED

INDOOR SYSTEM

FIBERGLASS BASIN

*Pump suspended from steel cover

- P/N 32-0029 24" x 36" (61 x 91 cm)

SK2628

- Fiberglass basin w/ AFD
- Rust-resistant steel cover (epoxy coated)
- 3" Adaptaflex vent seal and 4" rubber inlet pipe seal
- 1-1/4" brass anti-siphon device, 1-1/4" NPT brass check valve, and ball valve, field-installed

*Contact factory for other sizes and Duplex Configurations.

OUTDOOR SYS. w/ FLEX HOSE DC

FIBERGLASS BASIN AND COVER
1.25" FLEXIBLE HOSE w/ DISCONNECT

- P/N 35-0006 24" x 48" (61 x 122 cm)
- P/N 35-0007 24" x 60" (61 x 152 cm)
- P/N 35-0008 24" x 72" (61 x 183 cm)
- P/N 35-0084 24" x 84" (61 x 213 cm)

SK2540

- Fiberglass basin with anti-flotation ring
- Flex-hose discharge with disconnect
- 1-1/4" PVC discharge pipe from disconnect
- 1" Pull rod and 8' (2.4 m) stainless steel lifting cable
- 1-1/4" PVC ball valve(s), 1-1/4" brass check valve(s), and 1-1/4" brass anti-siphon device
- 1-4" Rubber inlet pipe seal (field inst.)
- Solid fiberglass cover with Zoeller imprint

OUTDOOR SYSTEM w/ Z-Rail

FIBERGLASS BASIN AND COVER
Z-RAIL DISCONNECT SYSTEM

- 24" x 60" (61 x 152 cm) P/N 33-1598
- 24" x 72" (61 x 183 cm) P/N 33-1597
- 24" x 84" (61 x 213 cm) P/N 33-1594
- 24" x 96" (61 x 244 cm) P/N 33-1596

SK3091

- Fiberglass basin with anti-flotation ring
- 1-1/4" Schedule 80 PVC discharge piping
- 1-1/4" H x 1-1/4" Z-rail® P/N 39-0137 disconnect system, epoxy coated ductile iron
- 3/4" Galvanized rail pipes
- Stainless steel lifting cable
- 1-1/4" brass ball valve
- 1-1/4" brass check valve
- Anti-siphon device
- PVC float tree
- 1-4" rubber inlet pipe seal (field inst.)
- 1-2" pipe seal (field inst.) for electrical conduit
- Solid fiberglass cover with Zoeller imprint

PREPACKAGED AND JOB READY SYSTEMS

ACCESSORIES FOR FIELD-ASSEMBLED SYSTEMS

FLEX-HOSE DISCHARGE ASM.
 P/N 10-2038 with 30" (76 cm) hose

Z-RAIL® DISCONNECT SYSTEM

- P/N 39-0137 1-1/4" (3.2 cm) H x 1-1/4" (3.2 cm) V Ductile Iron
- P/N 39-0138 1-1/4" (3.2 cm) H x 1-1/4" (3.2 cm) V with stainless steel upper bracket
- P/N 39-0139 Intermediate bracket stainless steel

STAINLESS STEEL LIFTING CABLES AND ROD

- P/N 39-0031 8' (2.4 m) Cable
- P/N 39-0032 12' (3.7 m) Cable
- P/N 39-0069 1' (0.3 m) Rod
- P/N 10-0789 Stainless steel lifting bail

PREWIRED CONDUIT

- (10-0580 Qwik Box Required)**
- P/N 5100-0016 - 25' (8 m)
 - P/N 5100-0017 - 35' (11 m)
 - P/N 5100-0018 - 50' (15 m)

GALVANIZED 1.25" DISCH. ELBOW
 P/N 018386

CHECK VALVE

- P/N 30-0223 1.25" NPT Brass

BALL VALVE

- P/N 30-0165 1.25" PVC
- P/N 30-0213 1.25" NPT Brass

FIELD-MOUNT SYSTEMS

SIMPLEX		OUTDOOR		INDOOR	
REQ.	REQ.	REQ.	REQ.	REQ.	REQ.
1 810 or 815 Grinder	P/N ____ (A)	1 810 or 815 Grinder	P/N ____ (A)	1 810 or 815 Grinder	P/N ____ (A)
1 Control panel/Alarm system	P/N ____ (B)	1 Control panel/Alarm system	P/N ____ (B)	1 Alarm panel	P/N ____ (B)
1 Piggyback pump switch	P/N ____ (C)	1 Piggyback pump switch	P/N ____ (C)	1 Piggyback pump switch	P/N ____ (C)
1 Control switch (if required)	P/N ____ (C)	1 Control switch (if required)	P/N ____ (C)	1 Weight for alarm float	P/N ____ (C)
1 Weight for alarm float (if required)	P/N ____ (D)	1 Junction Box (if required)	P/N ____ (D)	1 Basin, cover and hardware	P/N ____ (F)
1 Junction Box (Optional)	P/N ____ (F)	1 Basin, cover and hardware	P/N ____ (F)		
1 Optional accessories	P/N ____ (F)				
	P/N ____ (F)				
	P/N ____ (F)				
	P/N ____ (F)				